

## Variable Delivery Checkball Piston Pumps

### PV4000-11 SERIES

7.3 to 13.7 gpm (27,6 to 51,8 L/min) at 1800 rpm  
Rated: 6000 psi (420 bar), Maximum: 10 000 psi (700 bar)

PV4000-11 Series pumps supply infinitely variable flow, controlled by the linear movement of a volume stem control. Output is regulated by mechanically controlled variable inlet ports in each piston pumping chamber.

An optional pressure compensator overrides the volume control to smoothly and quietly regulate delivery. Fast response to load conditions assures full power in the system up to a pressure very close to the compensator setting.

### FOR USE ON CRITICAL SYSTEMS

#### Efficient High-Pressure Operation

Individual piston check valves provide long service life and greater volumetric efficiency, especially at high pressures and with low-lubricity fluids.

#### Handle Higher Loads

The compact design provides a high horsepower-to-weight ratio. The rugged wobble plate, with a stationary piston barrel, handles higher loads than other pump designs.

#### Contamination Tolerant

Checkball pumps operating in dirty environments are resistant to



contamination failure. Large fluid paths into pistons, and output through durable outlet check valves, allow contaminants to be flushed away.

### TYPICAL APPLICATIONS

These pumps operate reliably at high pressures with a wide range of fluids. This makes them ideal for harsh mobile and industrial applications.

They are used on test stands, aircraft ground support equipment, hydraulic presses and other critical, high-pressure systems.

The contamination tolerant pump design is an advantage on applications where system fluid cannot be totally cleaned by filtration, or where complete filtration is just not economical.

### Specifications

Pump Models	Theoretical Displacement		Output Flow at 1500 rpm <sup>①</sup>		Output Flow at 1800 rpm <sup>①</sup>		Rated Pressure		Maximum Pressure		Rated Speed	Max Speed
	CI/Rev	CC/Rev	U.S. gpm	L/min	U.S. gpm	L/min	psi	bar	psi	bar	rpm	rpm
PV4011-11	1.136	18.62	6.1	23,0	7.3	27,6	6000	420	8000	560	1800	1800
PV4016-11	1.605	26.30	8.9	33,7	10.7	40,5	6000	420	8000	560	1800	1800
PV4018-11	1.795	29.41	10.0	37,8	12.0	45,4	6000	420	8000	560	1800	1800
PV4020-11	2.022	33.13	11.4	43,1	13.7	51,8	6000	420	8000	560	1800	1800
PV4011H-11	1.136	18.62	5.8	22,0	7.0	26,4	8000	560	10000	700	1800	1800
PV4016H-11	1.605	26.30	8.6	32,4	10.3	38,9	8000	560	10000	700	1800	1800
PV4018H-11	1.795	29.41	9.7	36,6	11.6	43,9	8000	560	10000	700	1800	1800
PV4020H-11	2.022	33.13	11.0	41,6	13.2	49,9	8000	560	10000	700	1800	1800

<sup>①</sup> Output flow based on typical performance using 100 SUS (20 cSt) ISO 32 Mineral Oil at rated pressure with flooded inlet.

## SPECIFYING PUMP OPTIONS

The table lists specifications for standard pressure models, and for models with the “H” option. These high-pressure models operate at maximum pressures to 10 000 psi (700 bar). The “H” option requires a high-pressure coned and threaded or B.S.P. P. outlet port.

Refer to “Typical Model Code” on page 5 to specify all options.

## INSTALLATION AND OPERATING

Refer to separate Bulletin PSI.CB for general installation and operating recommendations.

### Mounting

S.A.E. D 4-bolt pattern with 0.25 inch (6,4 mm) pilot engagement.

### Shaft

Standard keyed shaft, 1.250 inch (31,75 mm) diameter;

Optional spline shaft, 1.248/1.247 inch diameter standard S.A.E. 14 tooth, 12/24 D.P. 30° involute spline.

### Outlet Port

Standard pressure models have S.A.E. o-ring boss (O.R.B) ports. High pressure “H” option models require the use of outlet port option “A” (Autoclave Medium Pressure, Butech M/P or equivalent fittings), or outlet port option “B” (British Standard Pipe Parallel fittings).

### Inlet Conditions

Pumps may require pressurized inlet conditions at higher speeds. Failure to meet minimum inlet requirements will result in slight flow reduction. Refer to the “Minimum Inlet Pressure” table.

### Pump Inlet/Drain Port *\*Required*

Note the location of the dual purpose inlet/drain port.

Acting as an inlet – this port increases volumetric efficiency by improving the filling of the piston chamber.

Acting as a drain – the port diverts unused fluid at low pressure from the chamber, providing improved circulation which dissipates heat.

## Minimum Inlet Pressure<sup>①②</sup>

Pump Models	Operating Speed					
	1200 rpm		1500 rpm		1800 rpm	
	psi	bar	psi	bar	psi	bar
PV4011	0	0	0	0	0	0
PV4016	0	0	0	0	0	0
PV4018	0	0	0	0	5	0.4
PV4020	0	0	0	0	5	0.4

① Values shown are based on fluid viscosity of 100 SUS (20 cSt).

② Inlet pressures higher than 10 psig (0,7 bar) require a high pressure shaft seal. Refer to “Typical Model Code” on page 5 to specify seals.

### Seal Options

Standard seals are Buna-N (Nitrile). Options include Fluorocarbon (Viton® or Fluorel®) or EPR for use with some phosphate ester fluids.

### Weight (Mass)

140 lb (64 kg)

### Fluid Guidelines

Refer to separate Bulletin PSB.CB1 for fluid recommendations and outlet port configurations.

Some pump models may require reduced operating pressures when using low-lubricity fluids.

Because of the wide range of fluid characteristics, contact the sales department for a review of any application using non-petroleum-based fluids.

## PUMP SELECTION

These mechanical variable pumps are not bi-rotational. Rotation must be specified, viewed from shaft end of pump.

Ordering requires a complete model code specifying rotation, shaft, seal, outlet port and control options. Refer to “Typical Model Code” on page 5.

### Volume Control

The function of the volume stem control can be specified to deliver either *full flow* or *zero flow* in the “out” (stem fully extended) position.

**Note:** A pressure compensator is not available with *zero flow out*.

The optional pressure compensator overrides the volume control to regulate delivery at a preset pressure up to 8000 psi (560 bar).

### Electrohydraulic Pump Control

PV4000 Series pumps use a bracket-mounted Dynex Remote Proportional Actuator (RPA) to stroke the pump volume control stem.

Electrohydraulic volume control can be added to a standard pump using a RPA and Bracket Kit.

The RPA requires a separate pilot supply: Minimum, 200 psi (15 bar); Maximum, 3000 psi (210 bar).

For complete RPA specifications, refer to [Remote Proportional Actuators](#) on the Dynex website.

### Assembly of RPA and Bracket Kit

For ease of shipping, electrohydraulic models are shipped as two sub-assemblies. The RPA/bracket sub-assembly must be mounted to the rear of the pump using the tie rods and nuts provided with the pump. Recommended torque is 40 lb•ft (54 N•m).

### Bracket Kit

Pump	Kit Number <sup>①</sup>
PV4000 Series Pumps	KP4R109047

① Kit includes a bracket and hardware. The Dynex Remote Proportional Actuator must be ordered separately.

# INSTALLATION DRAWINGS

All dimensions are shown in inches (millimeters in parentheses) and are nominal.

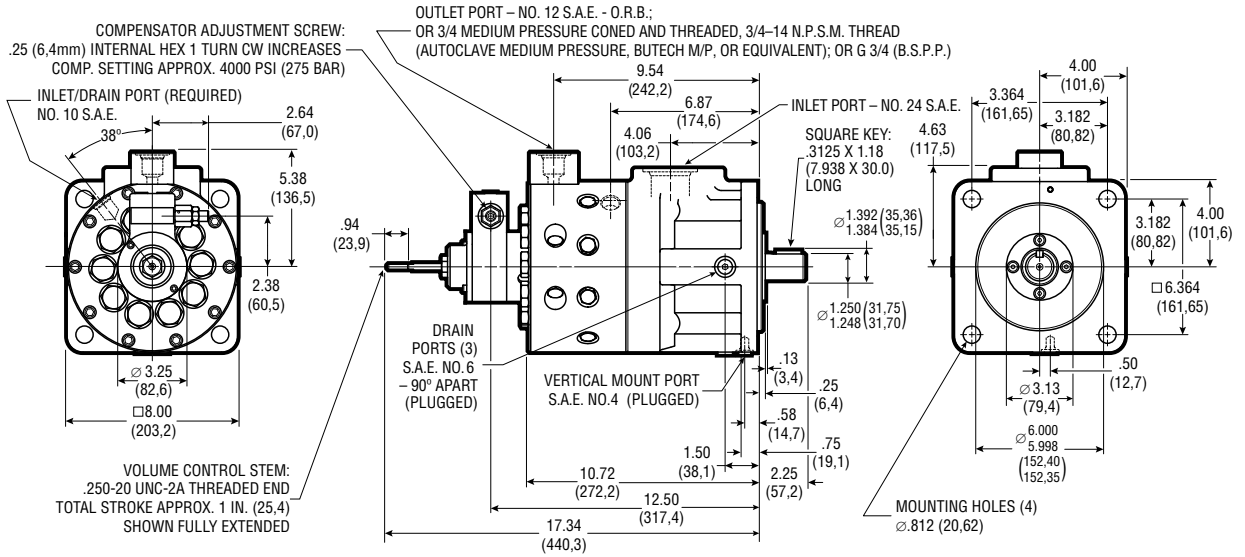

*Volume Stem Control Model*

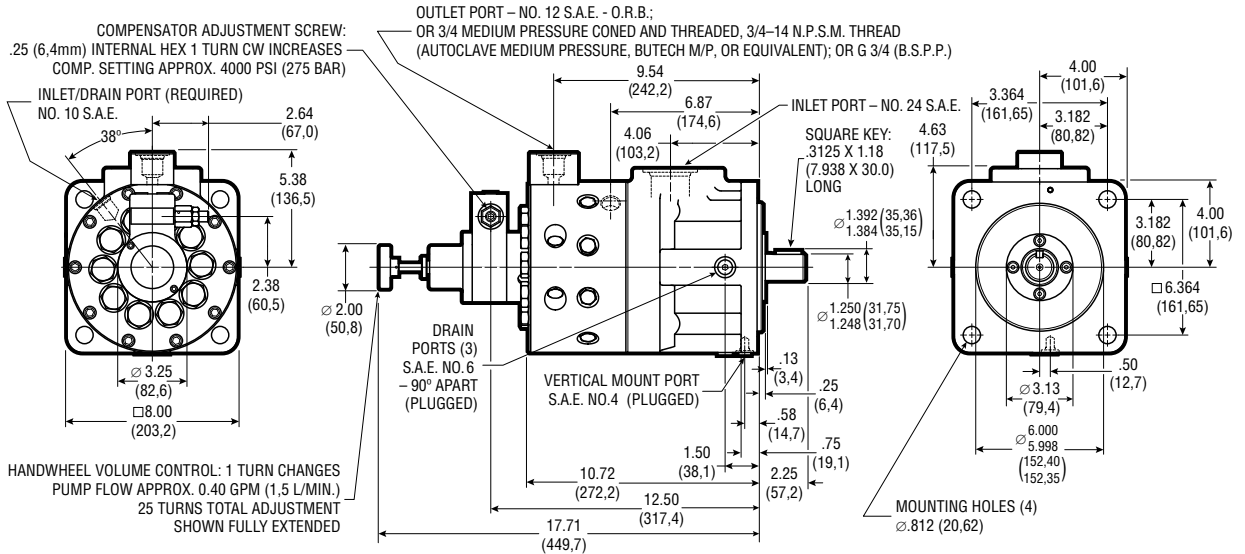

*Handwheel Volume Control Model*

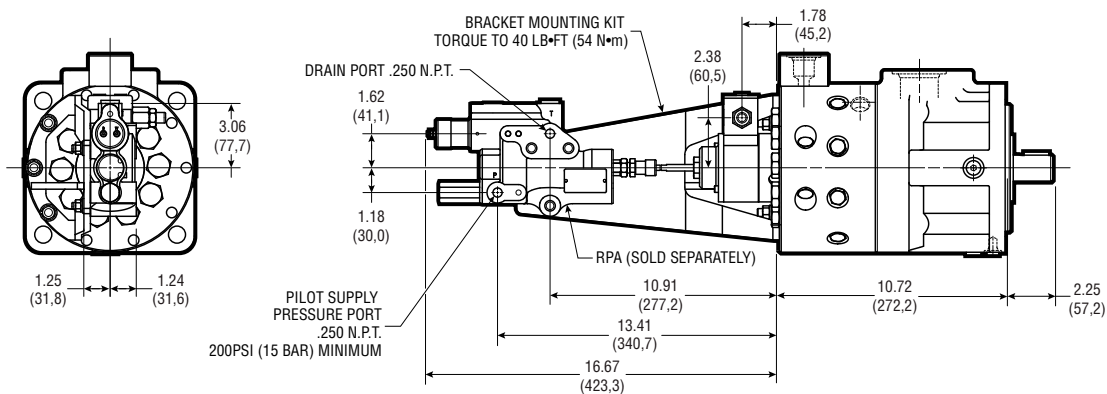

*Volume Stem Control Model Shown with Bracket Kit and RPA*

# Typical Performance Curves

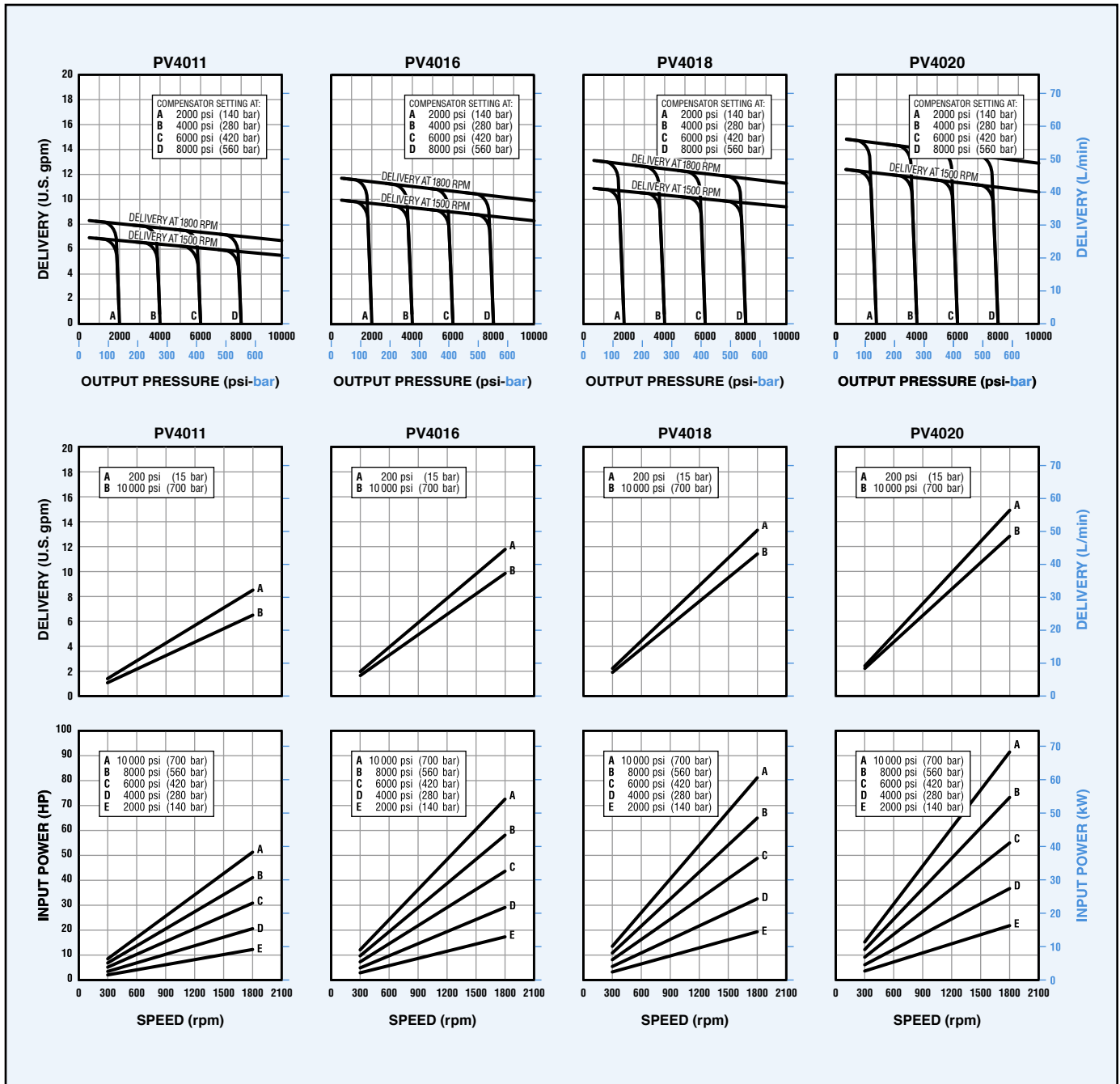

Typical performance curves are based on 100 SUS (20 cSt) mineral oil with pressurized inlet where required. Refer to "Minimum Inlet Pressure" table on page 2.

## Non-Compensated

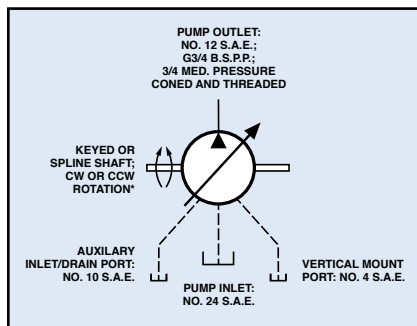

## Pressure Compensated

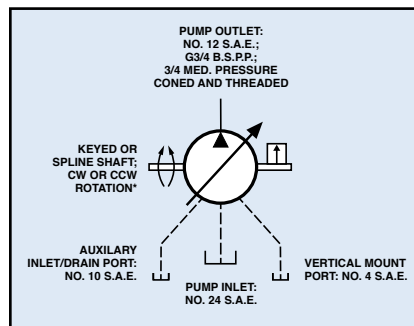

\* Rotation must be specified when ordering. This product is not bi-rotational.

# TYPICAL MODEL CODE

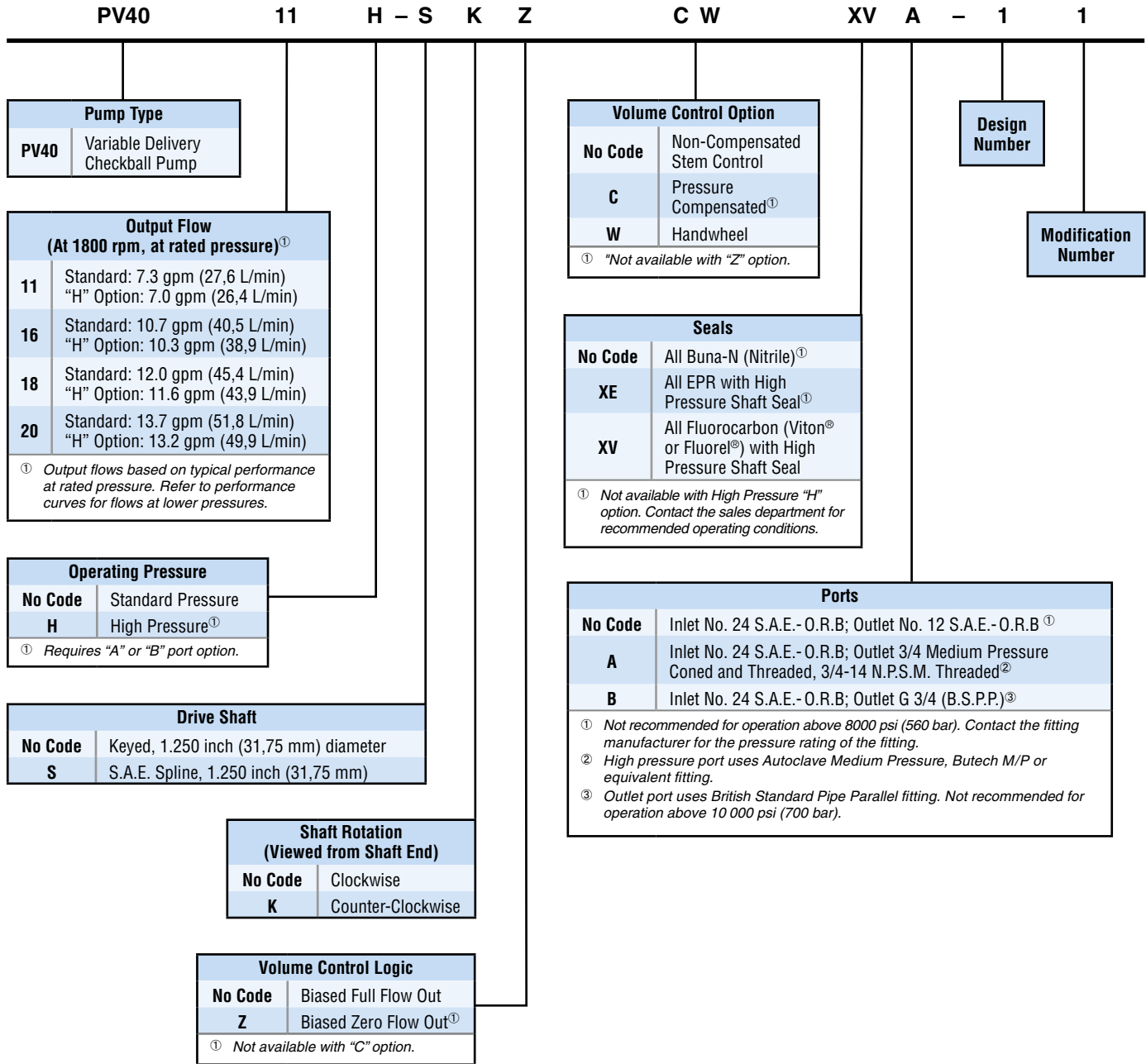

Specifications shown were in effect when printed. Since errors or omissions are possible, contact your sales representative or the sales department for the most current specifications before ordering. Dynex reserves the right to discontinue products or change designs at any time without incurring any obligation.

[www.dynexhydraulics.com](http://www.dynexhydraulics.com)

**USA Headquarters**  
 770 Capitol Drive  
 Pewaukee, WI 53072  
 Tel: 262-691-2222  
 FAX: 262-691-0312  
 E-mail: sales@dynexhydraulics.com

**Power Units & Systems**  
 54 Nickerson Road  
 Ashland, MA 01721  
 Tel: 508-881-5110  
 FAX: 508-881-6849  
 sales@ashland.dynexhydraulics.com

**European Sales**  
 Unit C5 Steel Close, Little End Road,  
 Eaton Socon, St Neots,  
 Cambs. PE19 8TT United Kingdom  
 Tel:+44 (0) 1480 213980 FAX:+44 (0) 1480 405662  
 E-mail: sales@dynexhydraulics.co.uk

## FLUID RECOMMENDATIONS (All Checkball Pumps)

### Mineral Oil

A high-grade premium petroleum-based fluid should be used to assure long component and system life. The fluid should have a combination of anti-wear, demulsibility, rust protection, oxidation-resistant and foam-resistant properties.

### Special Fluids

Various pump models are available for use with water-based fluids, diesel calibration fluids, phosphate ester fluids, machining coolant, brake fluid, various military fluids and other special fluids.

PF1300 & PF4300 Series pumps are compatible with a variety of water-based fluids. Refer to specific product documentation for specifications for these models, which are specifically rated for use with low-lubricity fluids.

Some pump models may require reduced operating pressures when using low-lubricity fluids.

Because of the wide range of fluid characteristics, contact the sales department for a review of any application using non-petroleum based fluids.

### Viscosity Specifications

Using fluid with the correct viscosity range is critical to achieving long component life.

Fluid conditions outside the "Optimum" range shown in the table may result in reduced pump output, requiring pressurized inlet conditions. For more information, contact the sales department.

## Hydraulic Fluid Viscosity<sup>①</sup>

Pump Models	Operating				Start-up <sup>②</sup>		Optimum		
	Minimum		Maximum		SUS	cSt	SUS	cSt	
	SUS	cSt	SUS	cSt					
<i>Fixed Displacement Pumps:</i>									
PF500-10	52	8	1911	413	3706	800	98 to 324	20 to 70	
PF1000-10	59	1,3	1911	413	3706	800	98 to 324	20 to 70	
PF1300-10	31	10	927	200	927	200	–	–	
PF2000	59	10	1911	413	1911	413	98 to 324	20 to 70	
PF2000 <sup>②</sup>	34	2,3	1911	413	1911	413	98 to 324	20 to 70	
PF3000-10	59	10	1911	413	3706	800	98 to 342	20 to 70	
PF4000-30	34	2,3	1911	413	1911	413	98 to 324	20 to 70	
PF4200-10	34	2,3	1911	413	1911	413	98 to 324	20 to 70	
PF4300-20	31	1,5	927	200	927	200	–	–	
PF6000	34	2,3	1911	413	1911	413	98 to 324	20 to 70	
<i>Mechanical Variable Delivery Pumps:</i>									
PV4000	34	2,3	1911	413	1911	413	98 to 324	20 to 70	
PV6000	34	2,3	1911	413	1911	413	98 to 324	20 to 70	
<i>Hydraulic Variable Delivery Pumps:</i>									
PV6000	34	2,3	1911	413	1911	413	98 to 324	20 to 70	

① Fluid conditions outside the "Optimum" range may result in reduced output, requiring pressurized inlet conditions. Contact the sales department.

② Models with special mounting.

## MINIMUM FILTRATION LEVELS

Pump inlet: 150 μ nominal;

Pressure or return line: 25 μ nominal.

While finer filtration levels than these are desirable and will result in longer component life, restricting flow to the pump inlet should be avoided. Minimum recommended inlet conditions must be maintained.

If a system component fails resulting in fluid contamination, it is important to drain and clean the reservoir, all lines, filter screens and all components. Refill with new fluid.

## INSTALLATION AND OPERATION

Refer to separate Bulletin: *Checkball Pumps Service, Installation and Operating Instructions* for general installation and operating recommendations.

That brochure includes information on mounting, shaft loading, sizing inlet pipe and hose, air bleed procedures and initial start-up. Guidelines for maintenance, repair and trouble-shooting are also included.

## OULET PORT CONFIGURATIONS

Dynex pumps are available with outlet ports suitable for use at various pressure ranges. Refer to the appropriate "Specification Table" or "Typical Model Code" to specify the required port.

Contact the fitting manufacturer to ensure the selected fittings are rated for the maximum pump operating pressure.

### S.A.E. Straight Thread Ports

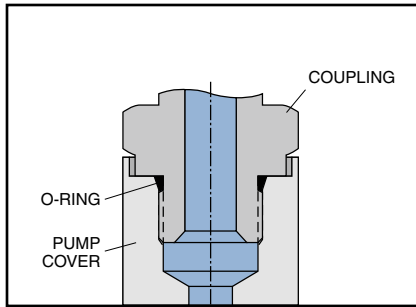

*Typical S.A.E. Straight Thread port connection*

The Straight Thread connection (S.A.E. J1926/1) is sometimes referred to as an S.A.E. O-ring Boss, or ORB. The port consists of a machined spotface surface, a tapered seal cavity and a straight thread port.

The fitting forms a seal by compressing the o-ring in the seal cavity with the underside of the flanged wrench flat. Some adjustable fittings, such as elbows and tees, use a locknut with a captive backup washer for compression.

S.A.E. Straight Thread ports are not recommended for operation above 8000 psi (560 bar). Also, the maximum pressure of pumps with No. 12 S.A.E. outlet ports may be limited by the pressure rating of the available fitting. Contact the fitting manufacturer for ratings.

### Coned and Threaded Ports

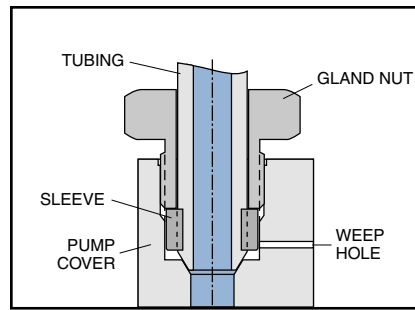

*Typical Coned and Threaded port connection*

High-pressure pumps are available with coned and threaded outlet ports, which use Autoclave Medium Pressure, Butech M/P, or equivalent fittings.

These fittings provide a metal-to-metal seal with an interference fit, not requiring an o-ring. The gland nut holds the sleeve and tubing against the cone surface.

A weep hole, visible on the outside of the pump cover, acts as an indicator of any abnormal leakage caused by system conditions (i.e., excessive pressure). It allows any fluid which does leak past the sealing surfaces to escape, preventing pressure build-up and possible damage.

### British Standard Pipe Ports

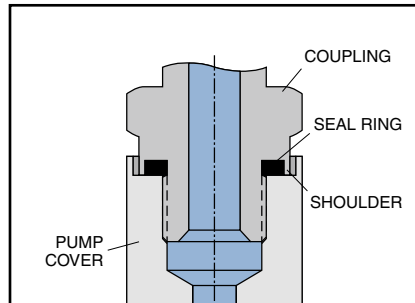

*Typical port connection with British Standard Pipe (Parallel) fitting with shoulder*

High-pressure pumps are available with flat face ports with British Standard Pipe (B.S.P.) parallel threads (BS 2779 or ISO 228), ideal for use on some European applications.

The fitting forms a seal by compressing a flat elastomer ring on a machined spotface surface. There are several sealing methods for these ports.

The recommended fitting has a recessed seal cavity formed by a shoulder on the underside of the flanged wrench flat (Voss "Peflex", Form B Shoulder Seal; or Parker Type E, "EOlastic" Seal; or equivalent).

B.S.P. ports are not recommended for operation above 10 000 psi (700 bar). Contact the fitting manufacturer, to ensure the selected fittings are rated for the maximum pump operating pressure.

### S.A.E. 4-Bolt Flange Ports

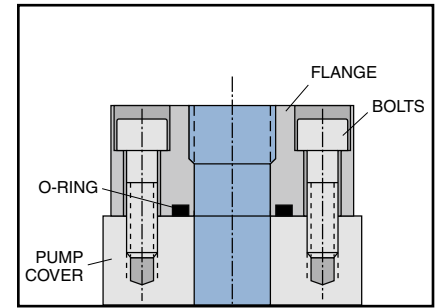

*Typical S.A.E. 4-Bolt Flange port connection*

Flange connections are often used for higher flows requiring larger diameter tubing. The port consists of an unthreaded port with four bolt holes in a rectangular pattern on a machined face around the port (S.A.E. J518).

A typical fitting consists of a flanged head with a welded tube and a captive flange with bolt holes. A seal is formed by an o-ring in the groove on the underside mounting surface of the flange head. As the flange bolts are alternately tightened, the o-ring is compressed between the flange head and the machined face on the pump.

To make mounting easier in tight spaces a two-piece split-flange is often used.