



3TH SERIES HEAVY DUTY HYDRAULIC CYLINDERS 3





ORDERING INFORMATION

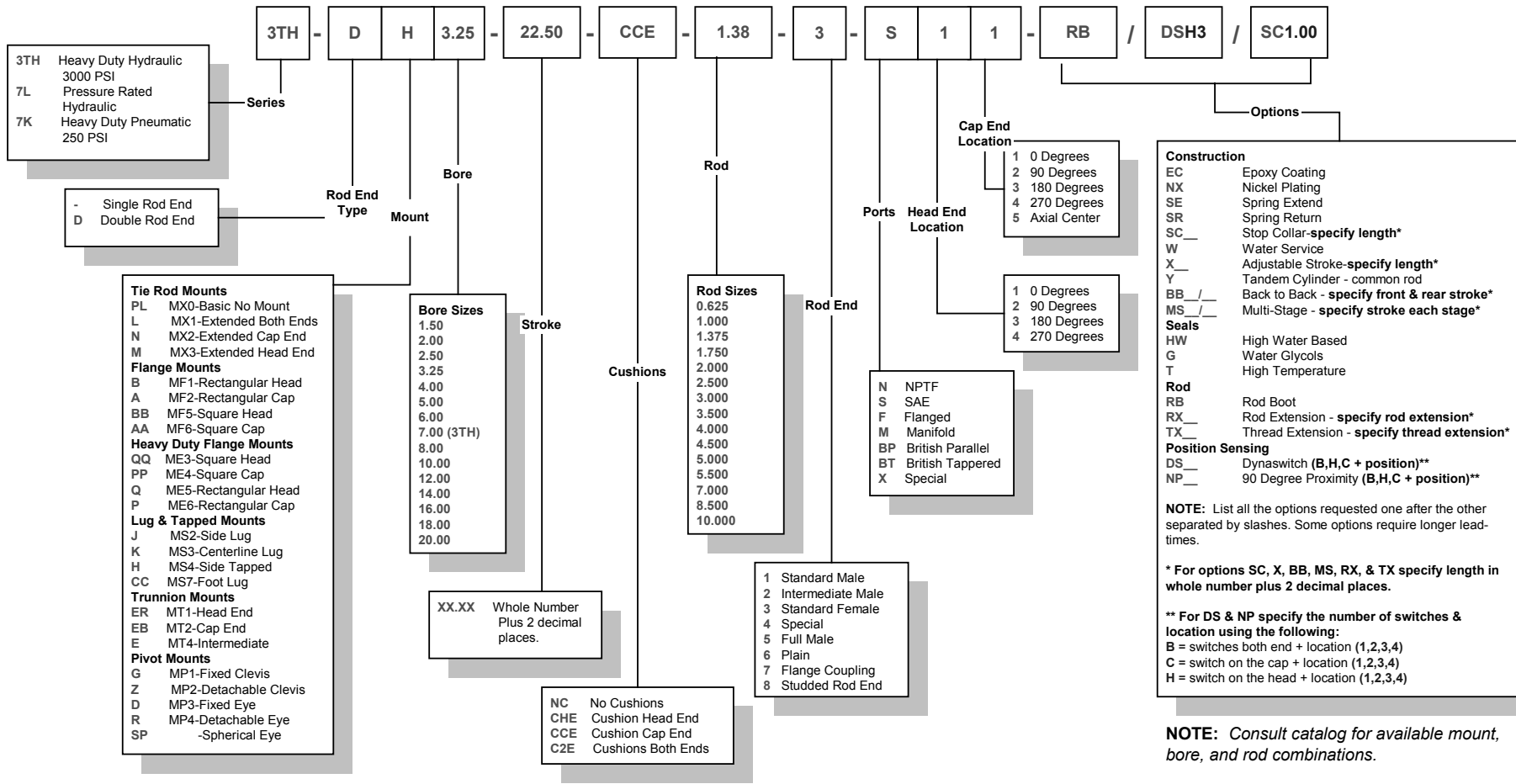

3TH-DH3.25-22.50-CCE-1.38-3-S11-RB/DSH3/SC1.00

For Rod End Dimensions see back cover foldout...

Series 3TH

Basic Cylinder No Mount

1.50" to 8.00"

STYLE O—Basic Plain Mount
(No Mounting)

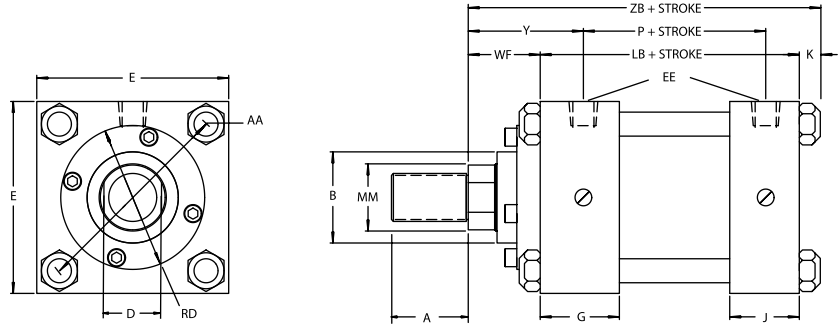

BORE	AA	DD	E	EE		F	G	J	K	R	ADD STROKE		
				NPTF	SAE						LB	LD	P
1½	2.3	¾-24	2½	½	8	¾	127/32	119/32	¾	1.63	4¾	4¾	27/8
2	2.9	½-20	3	½	8	5/8	127/32	119/32	7/16	2.05	4¾	4¾	213/16
2½	3.6	½-20	3½	½	8	5/8	127/32	119/32	7/16	2.55	4¾	5	215/16
3¼	4.6	5/8-18	4½	¾	12	¾	21/16	113/16	9/16	3.25	5½	5¾	3½
4	5.4	5/8-18	5	¾	12	7/8	21/16	113/16	9/16	3.82	5¾	6	3¾
5	7.0	7/8-14	6½	¾	12	7/8	21/8	17/8	13/16	4.95	6¼	6½	4¼
6	8.1	1-14	7½	1	16	1	2¼	2¼	15/16	5.73	7¾	7¾	5
7	9.3	1½-12	8½	1¼	20	1	2¾	2¾	1	6.58	8½	8½	5½
8	10.6	1¾-12	9½	1½	24	1	3	3	1/8	7.50	9½	9½	6¼

BORE	ROD DIA.	THREAD SIZE		ROD EXTENSIONS AND PILOT DIMENSIONS								ADD STROKE			ADD 2X STK.	
		MM	KK	FF	A	+0.000 -0.002 B	C	D	NA	FA	RD	VB	WF	Y		ZB
1½	5/8	7/16-20	1/2-20	3/4	1.124	3/8	1/2	9/16	3/8	2	5/8	1	2	6	7	67/8
	1	¾-16	7/8-14	11/8	1.499	1/2	7/8	15/16	3/8	—	7/8	13/8	23/8	67/8	73/8	77/8
2	1	¾-16	7/8-14	11/8	1.499	1/2	7/8	15/16	3/8	2¾	7/8	13/8	27/16	67/16	713/16	77/8
	1¾	1-14	1¼-12	15/8	1.999	5/8	11/8	15/16	5/8	—	1	15/8	211/16	611/16	87/16	87/8
2½	1	¾-16	7/8-14	11/8	1.499	1/2	7/8	15/16	3/8	2¾	7/8	13/8	27/16	69/16	715/16	7¾
	1¾	1¼-12	1½-12	2	2.374	¾	1½	111/16	5/8	—	11/8	17/8	215/16	71/16	87/16	8¾
	1¾	1-14	1¼-12	15/8	1.999	5/8	11/8	15/16	5/8	3¼	1	15/8	211/16	613/16	83/16	8¼
3¼	1¾	1-14	1¼-12	15/8	1.999	5/8	11/8	15/16	5/8	3¼	1	15/8	2¾	711/16	97/16	9
	2	1½-12	1¾-12	2¼	2.624	7/8	111/16	115/16	5/8	41/8	11/8	2	31/8	87/16	93/16	9¾
	1¾	1¼-12	1½-12	2	2.374	¾	1½	111/16	5/8	3¾	11/8	17/8	3	715/16	911/16	9½
4	1¾	1¼-12	1½-12	2	2.374	¾	1½	111/16	5/8	3¾	11/8	17/8	3	83/16	915/16	9¾
	2½	17/8-12	2¼-12	3	3.124	1	21/16	23/8	5/8	4½	1¼	2¼	33/8	89/16	105/16	10½
	2	1½-12	1¾-12	2¼	2.624	7/8	111/16	115/16	5/8	41/8	11/8	2	31/8	87/16	107/16	10
5	2	1½-12	1¾-12	2¼	2.624	7/8	111/16	115/16	5/8	41/8	11/8	2	31/8	91/16	117/16	10½
	3½	2½-12	31/4-12	3½	4.249	1	3	33/8	5/8	5½	1¼	2¼	33/8	93/16	1111/16	11
	2½	17/8-12	2¼-12	3	3.124	1	21/16	23/8	5/8	4½	1¼	2¼	33/8	93/16	1111/16	11
6	3	2¼-12	2¾-12	3½	3.749	1	25/8	27/8	5/8	5¼	1¼	2¼	33/8	93/16	1111/16	11
	2½	17/8-12	2¼-12	3	3.124	1	21/16	23/8	5/8	4½	1¼	2¼	37/16	109/16	13¼	117/8
	4	3-12	3¾-12	4	4.749	1	33/8	37/8	¾	6	1¼	2¼	37/16	109/16	13¼	117/8
7	3	2¼-12	2¾-12	3½	3.749	1	25/8	27/8	5/8	5¼	1¼	2¼	37/16	109/16	13¼	117/8
	3½	2½-12	31/4-12	3½	4.249	1	3	33/8	5/8	5½	1¼	2¼	37/16	113/4	13¼	117/8
	5	3½-12	4¾-12	5	5.749	1	4¼	47/8	¾	7¼	1¼	2¼	3¾	113/4	147/8	13
8	3½	2½-12	31/4-12	3½	4.249	1	3	33/8	5/8	5½	1¼	2¼	3¾	113/4	147/8	13
	4	3-12	3¾-12	4	4.749	1	33/8	37/8	¾	6	1¼	2¼	3¾	113/4	147/8	13
	4½	3¼-12	4¼-12	4½	5.249	1	37/8	43/8	¾	67/8	1¼	2¼	3¾	113/4	147/8	13
8	3½	2½-12	31/4-12	3½	4.249	1	3	33/8	5/8	5½	1¼	2¼	37/8	127/8	16¼	14
	5½	4-12	5¼-12	5½	6.249	1	43/8	53/8	¾	8	1¼	2¼	37/8	127/8	16¼	14
	4	3-12	3¾-12	4	4.749	1	33/8	37/8	¾	6	1¼	2¼	37/8	127/8	16¼	14
8	4½	3¼-12	4¼-12	4½	5.249	1	37/8	43/8	¾	67/8	1¼	2¼	37/8	127/8	16¼	14
	5	3½-12	4¾-12	5	5.749	1	4¼	47/8	¾	7¼	1¼	2¼	37/8	127/8	16¼	14

Series 3TH

Tie Rod Mounted Cylinders

1.50" to 8.00"

STYLE L—Tie Rods
Extended Both Ends
(NFPA Mounting Style MX1)

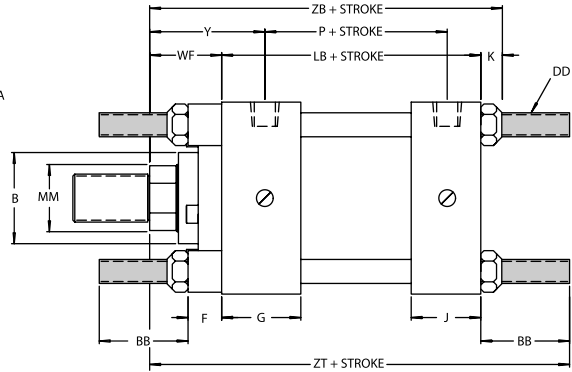
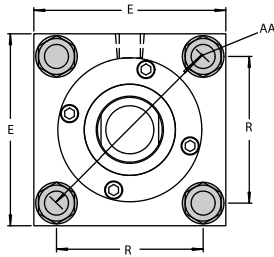

STYLE DL—Tie Rods
Extended Both Ends Double
Rod End Cylinder
(NFPA Mounting Style MDX1)

Double rod cylinders are available in all styles* except A, AA, EB, and G. Dimensions for other styles are the same as above with mounting added. Add prefix D to style when ordering. Example: DB HYD. CYL.

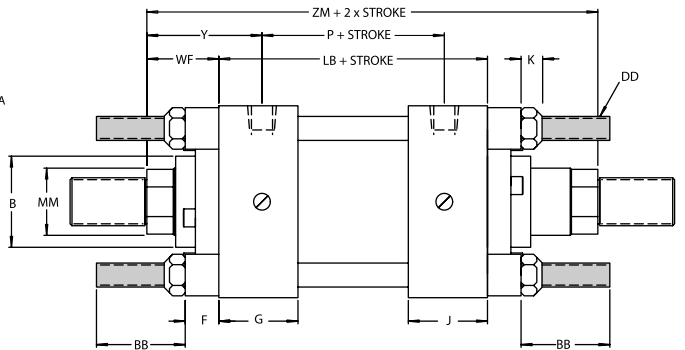
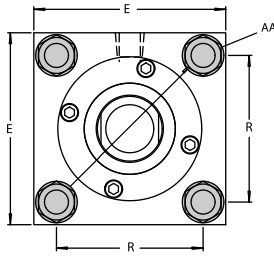

STYLE M—Tie Rods
Extended Head End
(NFPA Mounting Style MX3)

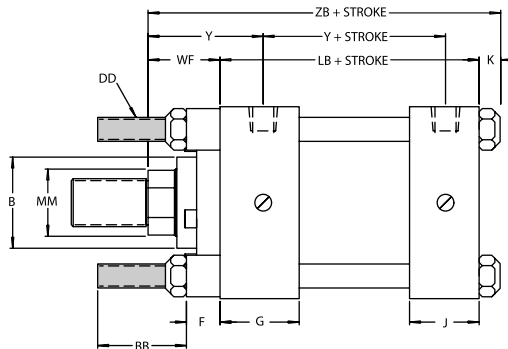
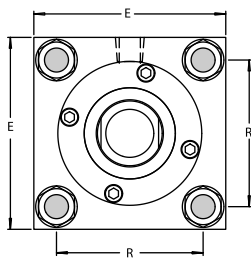

STYLE N—Tie Rods
Extended Cap End
(NFPA Mounting Style MX2)

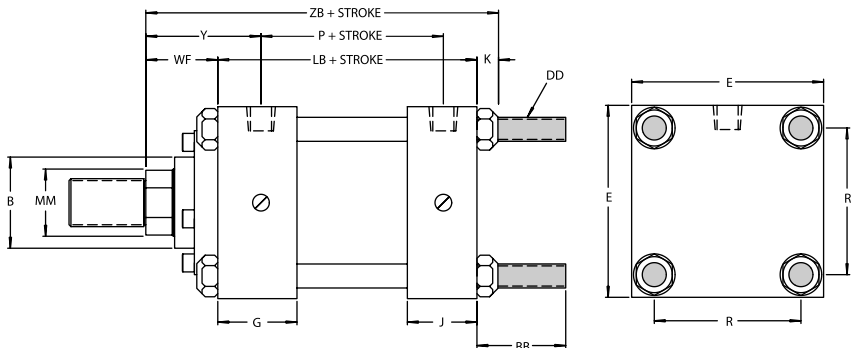

BB is standard tie rod extension on Styles L, M, N, DL and DM, but will be increased or decreased when specified. To do this, specify BB to be (so many) inches. Extra nuts are available for tie rod ends.
*Consult factory on availability of Style DCC cylinder.

ENVELOPE AND MOUNTING DIMENSIONS

BORE	AA	BB	DD	E	EE		F	G	J	K	R	ADD STROKE		
					NPTF	SAE						LB	LD	P
1½	2.3	1⅜	⅜-24	2½	½	8	⅜	1 ²⁷ / ₃₂	1 ¹⁹ / ₃₂	⅜	1.63	4⅜	4⅜	2⅞
2	2.9	1 ¹³ / ₁₆	½-20	3	½	8	⅝	1 ²⁷ / ₃₂	1 ¹⁹ / ₃₂	7/16	2.05	4⅜	4⅜	2 ¹³ / ₁₆
2½	3.6	1 ¹³ / ₁₆	½-20	3½	½	8	⅝	1 ²⁷ / ₃₂	1 ¹⁹ / ₃₂	7/16	2.55	4¾	5	2 ¹⁵ / ₁₆
3¼	4.6	2 ⁵ / ₁₆	⅝-18	4½	¾	12	¾	2 ¹ / ₁₆	1 ¹³ / ₁₆	9/16	3.25	5½	5¾	3½
4	5.4	2 ⁵ / ₁₆	⅝-18	5	¾	12	7/8	2 ¹ / ₁₆	1 ¹³ / ₁₆	9/16	3.82	5¾	6	3¾
5	7.0	3 ³ / ₁₆	7/8-14	6½	¾	12	7/8	2 ¹ / ₈	1 ⁷ / ₈	1 ³ / ₁₆	4.95	6¼	6½	4¼
6	8.1	3 ⁵ / ₈	1-14	7½	1	16	1	2¼	2¼	1 ⁵ / ₁₆	5.73	7⅜	7⅜	5
7	9.3	4⅞	1⅞-12	8½	1¼	20	1	2¾	2¾	1	6.58	8½	8½	5½
8	10.6	4½	1¼-12	9½	1½	24	1	3	3	1⅞	7.50	9½	9½	6¼

Head end cushions are non-available on 1½"-2½" bore cylinders with max. size rods. NPTF ports furnished as std. unless otherwise specified. SAE straight thread ports optional.

ROD END DIMENSIONS

ENVELOPE AND MOUNTING DIMENSIONS

BORE	ROD DIA.	THREAD SIZE		ROD EXTENSIONS AND PILOT DIMENSIONS										ADD STROKE		ADD 2X STK.
		MM	KK	FF	A	+000 -002 B	C	D	NA	FA	RD	VB	WF	Y	ZB	
1½	5/8	7/16-20	1/2-20	3/4	1.124	3/8	1/2	9/16	3/8	2	5/8	1	2	6	7	6⅞
	1	3/4-16	7/8-14	1⅞	1.499	1/2	7/8	15/16	3/8	—	7/8	13/8	2⅞	6⅞	7⅞	7⅞
2	1	3/4-16	7/8-14	1⅞	1.499	1/2	7/8	15/16	3/8	2¾	7/8	13/8	2 ⁷ / ₁₆	6 ⁷ / ₁₆	7 ¹³ / ₁₆	7⅞
	1⅜	1-14	1¼-12	1⅝	1.999	5/8	1⅞	1⅝	5/8	—	1	1⅝	2 ¹¹ / ₁₆	6 ¹¹ / ₁₆	8 ¹ / ₁₆	8⅞
2½	1	3/4-16	7/8-14	1⅞	1.499	1/2	7/8	15/16	3/8	2¾	7/8	13/8	2 ⁷ / ₁₆	6 ⁹ / ₁₆	7 ¹⁵ / ₁₆	7¾
	1¾	1¼-12	1½-12	2	2.374	¾	1½	1 ¹¹ / ₁₆	5/8	—	1⅞	1 ⁷ / ₈	2 ¹⁵ / ₁₆	7 ¹ / ₁₆	8 ⁷ / ₁₆	8¾
3¼	1⅜	1-14	1¼-12	1⅝	1.999	5/8	1⅞	1⅝	5/8	3¼	1	1⅝	2 ¹¹ / ₁₆	6 ¹³ / ₁₆	8 ³ / ₁₆	8¼
	2	1½-12	1¾-12	2¼	2.624	7/8	1 ¹¹ / ₁₆	1 ¹⁵ / ₁₆	5/8	4⅞	1⅞	2	3⅞	8 ¹ / ₁₆	9 ¹³ / ₁₆	9¾
4	1¾	1¼-12	1½-12	2	2.374	¾	1½	1 ¹¹ / ₁₆	5/8	3¼	1⅞	1 ⁷ / ₈	3	7 ¹⁵ / ₁₆	9 ¹¹ / ₁₆	9½
	2½	1⅞-12	2¼-12	3	3.124	1	2⅞	2⅞	5/8	4½	1¼	2¼	3⅞	8 ⁹ / ₁₆	10 ⁵ / ₁₆	10½
5	2	1½-12	1¾-12	2¼	2.624	7/8	1 ¹¹ / ₁₆	1 ¹⁵ / ₁₆	5/8	4⅞	1⅞	2	3⅞	8 ⁵ / ₁₆	10 ¹ / ₁₆	10
	3½	2½-12	3¼-12	3½	4.249	1	3	3⅞	5/8	5½	1¼	2¼	3⅞	9 ¹ / ₁₆	11 ⁷ / ₁₆	10½
6	2½	1⅞-12	2¼-12	3	3.124	1	2⅞	2⅞	5/8	4½	1¼	2¼	3⅞	8 ⁹ / ₁₆	10 ⁵ / ₁₆	10½
	4	3-12	3¾-12	4	4.749	1	3⅞	3⅞	¾	6	1¼	2¼	3⅞	9 ¹ / ₁₆	11 ⁷ / ₁₆	11
7	3	2¼-12	2¾-12	3½	3.749	1	2⅝	2⅞	5/8	5¼	1¼	2¼	3⅞	8 ⁵ / ₁₆	10 ¹ / ₁₆	10
	5	3½-12	4¾-12	5	5.749	1	4¼	4 ⁷ / ₈	¾	7¼	1¼	2¼	3⅞	9 ¹ / ₁₆	11 ⁷ / ₁₆	10½
8	3½	2½-12	3¼-12	3½	4.249	1	3	3⅞	5/8	5½	1¼	2¼	3⅞	8 ⁹ / ₁₆	10 ⁵ / ₁₆	10
	5½	4-12	5¼-12	5½	6.249	1	4⅝	5⅜	¾	8	1¼	2¼	3⅞	9 ¹ / ₁₆	11 ⁷ / ₁₆	10½
8	4	3-12	3¾-12	4	4.749	1	3⅞	3⅞	¾	6	1¼	2¼	3⅞	8 ⁵ / ₁₆	10 ¹ / ₁₆	10
	4½	3¼-12	4¼-12	4½	5.249	1	3⅞	4⅜	¾	6⅞	1¼	2¼	3⅞	9 ¹ / ₁₆	11 ⁷ / ₁₆	10½
8	5	3½-12	4¾-12	5	5.749	1	4¼	4 ⁷ / ₈	¾	7¼	1¼	2¼	3⅞	9 ¹ / ₁₆	11 ⁷ / ₁₆	10½
	5	3½-12	4¾-12	5	5.749	1	4¼	4 ⁷ / ₈	¾	7¼	1¼	2¼	3⅞	9 ¹ / ₁₆	11 ⁷ / ₁₆	10½

Series 3TH

Foot Mounted Cylinders

1.50" to 8.00"

STYLE J—Side Lug Mount (NFPA Mounting Style MS2)

Do not specify ports in #2 or #4 position without checking clearance between pipe fitting and mounting bolt head. On Bores 1½–4 the mount lug must be C Bored to yield clearance for supply piping when ports are at position #2 or #4.

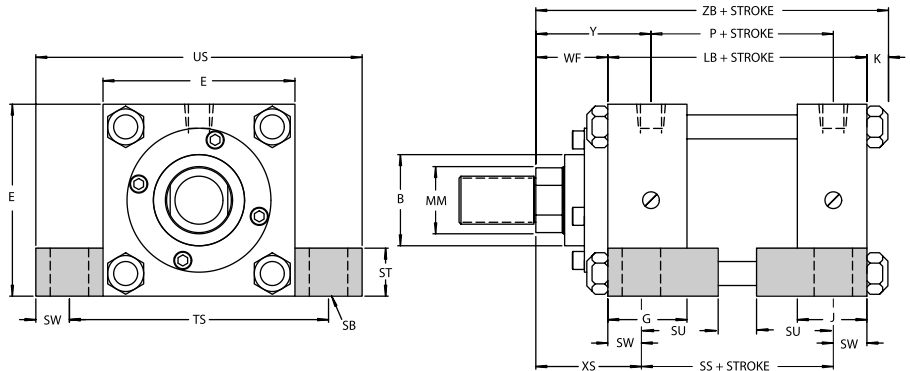

STYLE K—Center Line Mount (NFPA Mounting Style MS3)

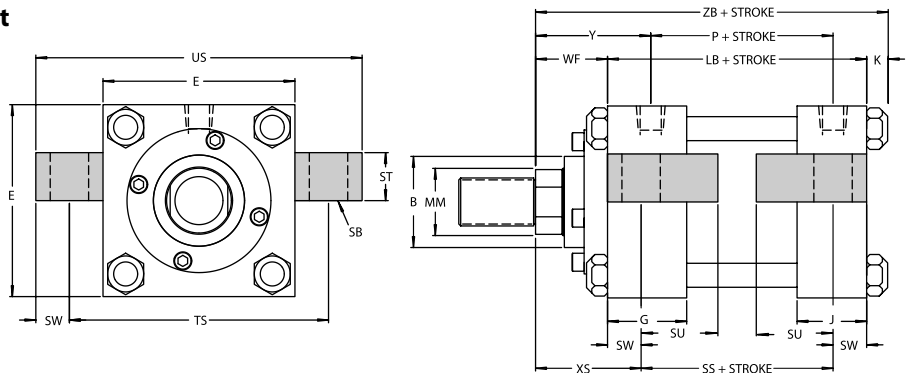

STYLE CC—Foot Mount (NFPA Mounting Style MS7)

Foot lugs may interfere with accessories such as the rod eye and rod clevis. "WF" dimension must be increased to provide clearance for mating part.

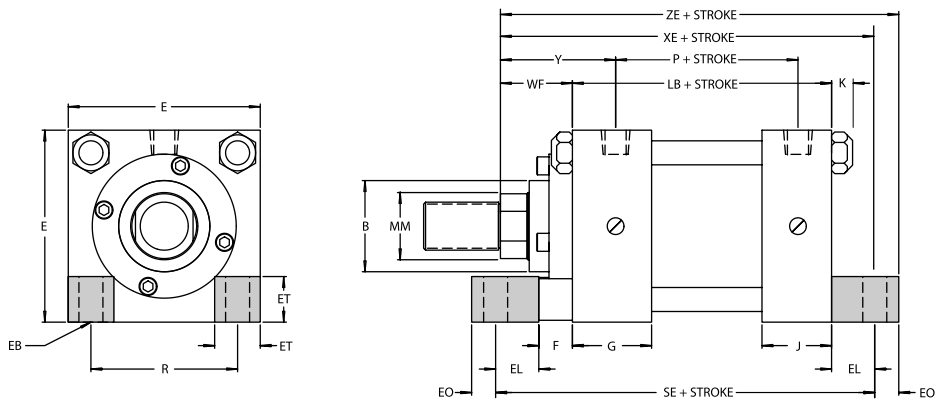

STYLE H—Side Flush Mount (NFPA Mounting Style MS4)

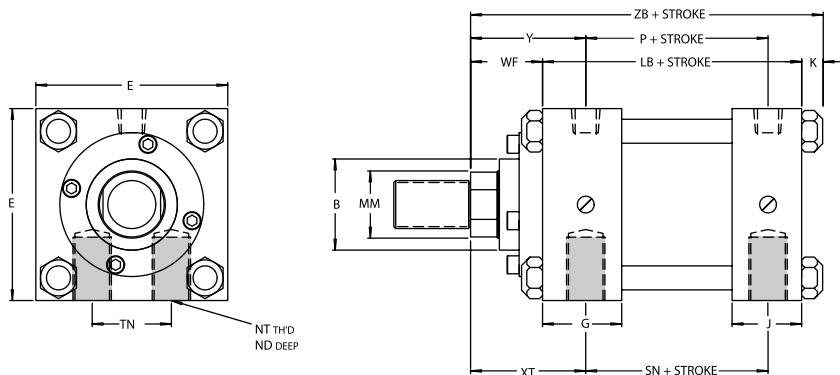

ENVELOPE AND MOUNTING DIMENSIONS

BORE	E	EB*	EE		EL	EO	ET	F	G	J	K	NT	R	SB*	ST	SU	SW	TN	TS	US	ADD STROKE				
			NPTF	SAE																	LB	P	SE	SN	SS
1½	2½	¾	½	8	7/8	¾	7/8	¾	1 ²⁷ / ₃₂	1 ¹⁹ / ₃₂	¾	¾-16	1.63	¾	½	1 ¹⁵ / ₁₆	¾	¾	¾	4	4 ⁵ / ₈	2 ⁷ / ₈	6 ³ / ₄	2 ⁷ / ₈	3 ⁷ / ₈
2	3	½	½	8	1 ⁵ / ₁₆	½	1 ⁵ / ₁₆	5/8	1 ²⁷ / ₃₂	1 ¹⁹ / ₃₂	7/16	½-13	2.05	½	¾	1¼	½	1 ⁵ / ₁₆	4	5	4 ⁵ / ₈	2 ¹³ / ₁₆	7 ¹ / ₈	2 ⁷ / ₈	3 ⁵ / ₈
2½	3½	½	½	8	1 ⁵ / ₁₆	½	1 ⁵ / ₁₆	5/8	1 ²⁷ / ₃₂	1 ¹⁹ / ₃₂	7/16	5/8-11	2.55	¾	1	1 ⁹ / ₁₆	1 ¹¹ / ₁₆	1 ⁵ / ₁₆	4 ⁷ / ₈	6¼	4 ³ / ₄	2 ¹⁵ / ₁₆	7¼	3	3 ³ / ₈
3¼	4½	5/8	¾	12	1 ¹ / ₈	5/8	1¼	¾	2 ¹ / ₁₆	1 ¹³ / ₁₆	9/16	¾-10	3.25	¾	1	1 ⁹ / ₁₆	1 ¹¹ / ₁₆	1½	5 ⁷ / ₈	7¼	5½	3½	8½	3½	4 ¹ / ₈
4	5	5/8	¾	12	1 ¹ / ₈	5/8	1¼	¾	2 ¹ / ₁₆	1 ¹³ / ₁₆	9/16	1-8	3.82	1	1¼	2	7/8	2 ¹ / ₁₆	6¾	8½	5¾	3¾	8 ⁷ / ₈	3¾	4
5	6½	7/8	¾	12	1½	¾	1 ⁹ / ₁₆	7/8	2 ¹ / ₁₆	1 ¹³ / ₁₆	1 ⁷ / ₈	1-8	4.95	1	1¼	2	7/8	2 ¹⁵ / ₁₆	8¼	10	6¼	4¼	10 ¹ / ₈	4¼	4½
6	7½	1	1	16	1 ¹¹ / ₁₆	7/8	1¾	1	2¼	2¼	1 ⁵ / ₁₆	1¼-7	5.73	1¼	1½	2½	1 ¹ / ₈	3 ⁵ / ₁₆	9¾	12	7 ³ / ₈	5	11¾	5 ¹ / ₈	5 ¹ / ₈
7	8½	1 ¹ / ₈	1¼	20	1 ¹³ / ₁₆	1	1 ¹⁵ / ₁₆	1	2¾	2¾	1	1½-6	6.58	1½	1¾	2 ⁷ / ₈	1 ³ / ₈	3¾	11¼	14	8½	5½	13 ¹ / ₈	5 ¹ / ₈	5¾
8	9½	1¼	1½	24	2	1 ¹ / ₈	2	1	3	3	1 ¹ / ₈	1½-6	7.50	1½	1¾	2 ⁷ / ₈	1 ³ / ₈	4¼	12¼	15	9½	6¼	14½	6 ⁵ / ₈	6¾

Head end cushions are non-available on 1½"-2"-2½" bore cylinders with max. size rods. NPTF ports furnished as standard unless otherwise specified. SAE straight thread ports optional. Styles J, H, K and CC should be pinned or keyed to prevent shifting at one end only.
 *Mounting holes are 1/16" larger than screw size shown.

ROD END DIMENSIONS

ENVELOPE AND MOUNTING DIMENSIONS

BORE	ROD DIA.	THREAD SIZE		ROD EXTENSIONS AND PILOT DIMENSIONS												ADD STROKE			
		MM	KK	FF	A	+000 -002 B	C	D	NA	FA	RD	VB	WF	Y	ND	XS	XT	XE	ZB
1½	5/8	7/16-20	1/2-20	¾	1.124	¾	½	9/16	¾	2	5/8	1	2	9/16	1 ³ / ₈	2	6½	6	6 ⁷ / ₈
	1	¾-16	7/8-14	1 ¹ / ₈	1.499	½	7/8	1 ⁵ / ₁₆	¾	—	7/8	1 ³ / ₈	2 ³ / ₈	7/16	1 ³ / ₄	2 ³ / ₈	6 ⁷ / ₈	6 ³ / ₈	7¼
2	1	¾-16	7/8-14	1 ¹ / ₈	1.499	½	7/8	1 ⁵ / ₁₆	¾	2¾	7/8	1 ³ / ₈	2 ⁷ / ₁₆	¾	1 ⁷ / ₈	2 ³ / ₈	6 ¹⁵ / ₁₆	6 ⁷ / ₁₆	7 ¹ / ₁₆
	1¾	1-14	1¼-12	1 ⁵ / ₈	1.999	5/8	1 ¹ / ₈	1 ⁵ / ₁₆	5/8	—	1	1 ⁵ / ₈	2 ¹¹ / ₁₆	7/16	2 ¹ / ₈	2 ⁵ / ₈	7 ³ / ₁₆	6 ¹ / ₁₆	7 ¹¹ / ₁₆
2½	1	¾-16	7/8-14	1 ¹ / ₈	1.499	½	7/8	1 ⁵ / ₁₆	¾	2¾	7/8	1 ³ / ₈	2 ⁷ / ₁₆	1 ⁵ / ₁₆	2 ¹ / ₁₆	2 ³ / ₈	7 ¹ / ₁₆	6 ⁹ / ₁₆	7 ⁹ / ₁₆
	1¾	1¼-12	1½-12	2	2.374	¾	1½	1 ¹¹ / ₁₆	5/8	—	1 ¹ / ₈	1 ⁷ / ₈	2 ¹⁵ / ₁₆	7/16	2 ⁹ / ₁₆	2 ⁷ / ₈	7 ⁹ / ₁₆	7 ¹ / ₁₆	8 ¹ / ₁₆
3¼	1¾	1-14	1¼-12	1 ⁵ / ₈	1.999	5/8	1 ¹ / ₈	1 ⁵ / ₁₆	5/8	3¼	1	1 ⁵ / ₈	2 ¹¹ / ₁₆	¾	2 ⁵ / ₁₆	2 ⁵ / ₈	7 ⁵ / ₁₆	6 ³ / ₁₆	7 ¹³ / ₁₆
	2	1½-12	1¾-12	2¼	2.624	7/8	1 ¹ / ₁₆	1 ⁵ / ₁₆	5/8	4 ¹ / ₈	1 ¹ / ₈	2	3 ¹ / ₈	1½	2 ¹¹ / ₁₆	3 ¹ / ₈	8 ¹ / ₄	7 ¹¹ / ₁₆	8 ⁷ / ₈
4	1¾	1¼-12	1½-12	2	2.374	¾	1½	1 ¹¹ / ₁₆	5/8	3¼	1 ¹ / ₈	1 ⁷ / ₈	3	1	2 ³ / ₄	3	8 ³ / ₄	8 ³ / ₁₆	9 ³ / ₈
	2½	1 ⁷ / ₈ -12	2¼-12	3	3.124	1	2 ¹ / ₁₆	2 ³ / ₈	5/8	4½	1¼	2¼	3 ³ / ₈	9/16	3 ³ / ₈	3 ³ / ₈	9 ¹ / ₈	8 ⁹ / ₁₆	9 ³ / ₄
5	2	1½-12	1¾-12	2¼	2.624	7/8	1 ¹¹ / ₁₆	1 ⁵ / ₁₆	5/8	4 ¹ / ₈	1 ¹ / ₈	2	3 ¹ / ₈	1½	2 ⁷ / ₈	3 ¹ / ₈	9¾	9 ¹ / ₁₆	10½
	3½	2½-12	3¼-12	3½	4.249	1	3	3 ³ / ₈	5/8	5½	1¼	2¼	3 ³ / ₈	¾	3 ¹ / ₈	3 ³ / ₈	10	9 ⁹ / ₁₆	10¾
6	2½	1 ⁷ / ₈ -12	2¼-12	3	3.124	1	2 ¹ / ₁₆	2 ³ / ₈	5/8	4½	1¼	2¼	3 ¹ / ₁₆	1 ⁷ / ₈	3 ³ / ₈	3½	11 ⁵ / ₁₆	10 ⁹ / ₁₆	12 ³ / ₁₆
	4	3-12	3¾-12	4	4.749	1	3 ³ / ₈	3 ³ / ₈	¾	6	1¼	2¼	3 ¹ / ₁₆	1 ⁵ / ₁₆	3 ³ / ₈	3½	11 ⁵ / ₁₆	10 ⁹ / ₁₆	12 ³ / ₁₆
7	3	2¼-12	2¾-12	3½	3.749	1	2 ³ / ₈	2 ⁷ / ₈	5/8	5¼	1¼	2¼	3¼	1 ⁷ / ₈	3 ⁵ / ₈	3 ¹³ / ₁₆	12 ⁹ / ₁₆	11¾	13 ⁹ / ₁₆
	5	3½-12	4¾-12	5	5.749	1	4¼	4 ⁷ / ₈	¾	7¼	1¼	2¼	3¼	7/8	3 ⁵ / ₈	3 ¹³ / ₁₆	12 ⁹ / ₁₆	11¾	13 ⁹ / ₁₆
8	3½	2½-12	3¼-12	3½	4.249	1	3	3 ³ / ₈	5/8	5½	1¼	2¼	3¼	1¾	3 ⁵ / ₈	3 ¹³ / ₁₆	12 ⁹ / ₁₆	11¾	13 ⁹ / ₁₆
	4½	3¼-12	4¼-12	4½	5.249	1	3 ³ / ₈	4 ⁷ / ₈	¾	6 ⁷ / ₈	1¼	2¼	3¼	1¼	3 ⁵ / ₈	3 ¹³ / ₁₆	12 ⁹ / ₁₆	11¾	13 ⁹ / ₁₆
8	3½	2½-12	3¼-12	3½	4.249	1	3	3 ³ / ₈	5/8	5½	1¼	2¼	3 ³ / ₈	2¼	3 ⁵ / ₈	3 ¹⁵ / ₁₆	13¾	12 ⁷ / ₈	14 ⁷ / ₈
	5½	4-12	5¼-12	5½	6.249	1	4 ³ / ₈	5 ³ / ₈	¾	8	1¼	2¼	3 ³ / ₈	1¼	3 ⁵ / ₈	3 ¹⁵ / ₁₆	13¾	12 ⁷ / ₈	14 ⁷ / ₈
8	4	3-12	3¾-12	4	4.749	1	3 ³ / ₈	3 ³ / ₈	¾	6	1¼	2¼	3 ³ / ₈	2 ¹ / ₈	3 ⁵ / ₈	3 ¹⁵ / ₁₆	13¾	12 ⁷ / ₈	14 ⁷ / ₈
	4½	3¼-12	4¼-12	4½	5.249	1	3 ³ / ₈	4 ⁷ / ₈	¾	6 ⁷ / ₈	1¼	2¼	3 ³ / ₈	1 ⁷ / ₈	3 ⁵ / ₈	3 ¹⁵ / ₁₆	13¾	12 ⁷ / ₈	14 ⁷ / ₈
8	4½	3¼-12	4¼-12	4½	5.249	1	3 ³ / ₈	4 ⁷ / ₈	¾	6 ⁷ / ₈	1¼	2¼	3 ³ / ₈	1½	3 ⁵ / ₈	3 ¹⁵ / ₁₆	13¾	12 ⁷ / ₈	14 ⁷ / ₈
	5	3½-12	4¾-12	5	5.749	1	4¼	4 ⁷ / ₈	¾	7¼	1¼	2¼	3 ³ / ₈	1½	3 ⁵ / ₈	3 ¹⁵ / ₁₆	13¾	12 ⁷ / ₈	14 ⁷ / ₈

Series 3TH

Pivot Mounted Cylinders

8.00" to 14.00"

STYLE ER—Trunnion Mount Head End (NFPA Mounting Style MT1)

Cylinders with "ER" mounts in bores 5" thru 8" with piston rods other than standard should not be used for pressures in excess of 2000 psi.

Pintles on trunnion mounted cylinders are designed to withstand shear loads, but not high bending loads. Pillow blocks must be rigidly mounted to provide full support with minimum clearances.

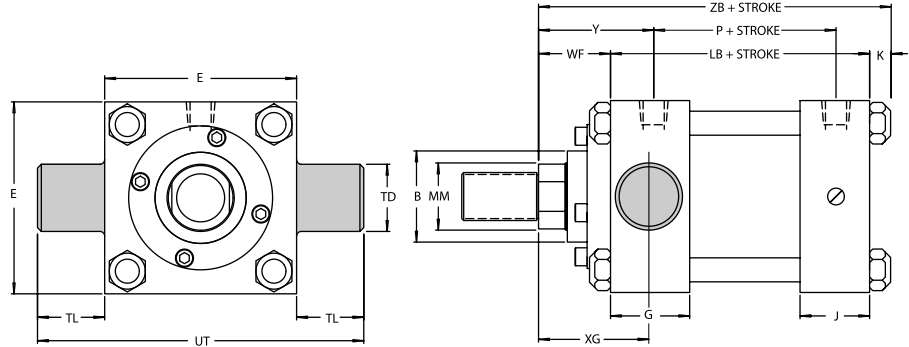

STYLE EB—Trunnion Mount Cap End (NFPA Mounting Style MT2)

The trunnion pintles on Styles ER and EB are not removable. For information on removable pintles, please consult the engineering department. On all intermediate trunnion mounts the trunnion pintles are an integral part of the mount. All intermediate trunnion mounts are closely fitted into a groove on the cylinder barrel. The position of the intermediate trunnion mount is not adjustable.

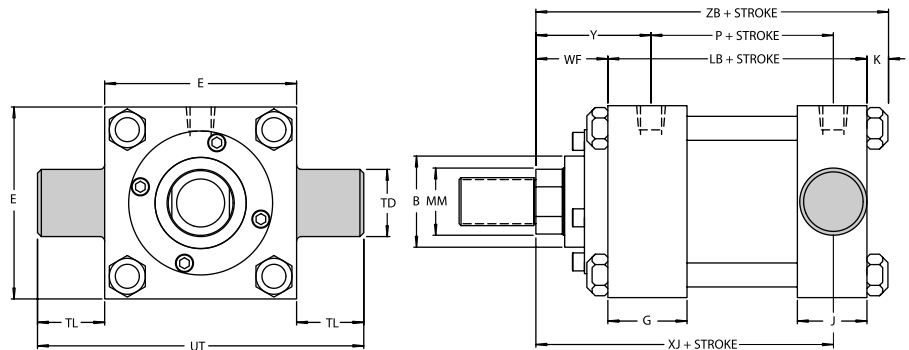

STYLE E—Intermediate Trunnion Mount (NFPA Mounting Style MT4)

Customer to specify Trunnion Location (XI Dim.)

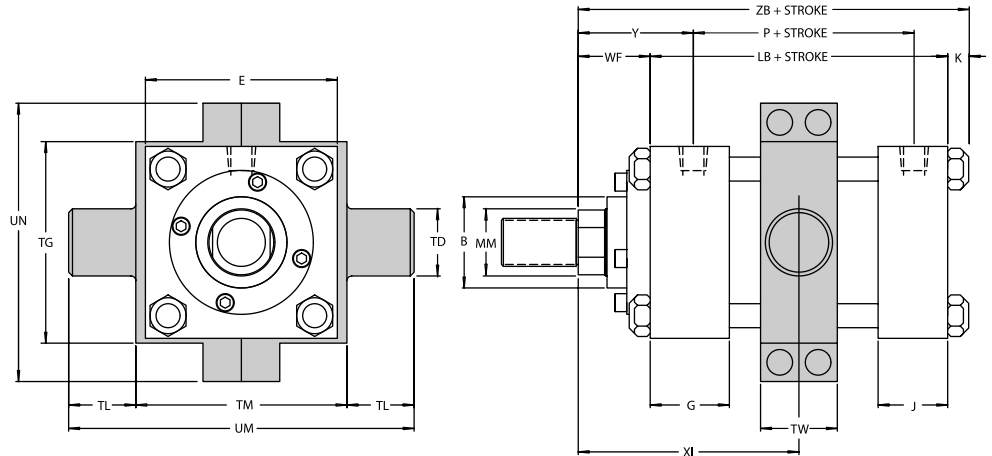

STYLE G—Clevis Mount (NFPA Mounting Style MP1)

Chrome-plated Clevis Pin Assembly (with Snap Rings) is furnished with all Style G Cylinders.

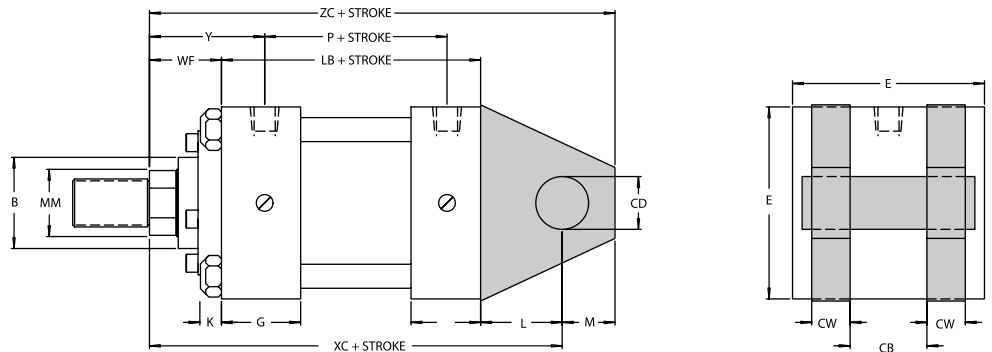

ENVELOPE AND MOUNTING DIMENSIONS

BORE	CB	±001 CD	CW	E	EE		G	J	K	L	LR	M	MR	+001 -001 TD	TL	TG	TM	TW	UM	UN	UT	ADD STROKE	
					NPTF	SAE																LB	P
1 1/2	3/4	1/2	1/2	2 1/2	1/2	8	1 27/32	1 19/32	3/8	3/4	5/8	1/2	1 19/32	1	1	2 1/4	3	1 1/4	5	4	4 1/2	4 5/8	2 7/8
2	1 1/4	3/4	5/8	3	1/2	8	1 27/32	1 19/32	7/16	1 1/4	15/16	3/4	2 29/32	1 3/8	1 3/8	3 1/4	3 1/2	1 1/2	6 1/4	4 3/4	5 3/4	4 5/8	2 13/16
2 1/2	1 1/4	3/4	5/8	3 1/2	1/2	8	1 27/32	1 19/32	7/16	1 1/4	15/16	3/4	2 29/32	1 3/8	1 3/8	3 3/4	4	1 1/2	6 3/4	5 1/4	6 1/4	4 3/4	2 15/16
3 1/4	1 1/2	1	3/4	4 1/2	3/4	12	2 1/16	1 13/16	9/16	1 1/2	1 5/16	1	1 3/16	1 3/4	1 3/4	4 1/4	5	2	8 1/2	6 3/4	8	5 1/2	3 1/2
4	2	1 3/8	1	5	3/4	12	2 1/16	1 13/16	9/16	2 1/8	1 3/4	1 3/8	1 29/32	1 3/4	1 3/4	5 1/4	5 1/2	2	9	7 1/4	8 1/2	5 3/4	3 3/4
5	2 1/2	1 3/4	1 1/4	6 1/2	3/4	12	2 1/8	1 7/8	13/16	2 1/4	2	1 3/4	1 29/32	1 3/4	1 3/4	6 1/4	7	2	10 1/2	9	10	6 1/4	4 1/4
6	2 1/2	2	1 1/4	7 1/2	1	16	2 1/4	2 1/4	15/16	2 1/2	2 1/4	2	2 3/16	2	2	7 3/4	8 1/2	3	12 1/2	10 1/4	11 1/2	7 3/8	5
7	3	2 1/2	1 1/2	8 1/2	1 1/4	20	2 3/4	2 3/4	1	3	2 3/4	2 1/2	2 5/8	2 1/2	2 1/2	8 3/4	9 1/4	3	14 3/4	11 1/2	13 1/2	8 1/2	5 1/2
8	3	3	1 1/2	9 1/2	1 1/2	24	3	3	1 1/8	3 1/4	3 1/16	2 3/4	2 7/8	3	3	10	11	3 1/2	17	12 3/4	15 1/2	9 1/2	6 1/4

Head end cushions are non-available on 1 1/2"-2"-2 1/2" bore cylinders with max. size rods. NPTF ports furnished as standard unless otherwise specified. SAE straight thread ports optional.

ENVELOPE AND MOUNTING DIMENSIONS

ROD END DIMENSIONS

BORE	ROD DIA. MM	THREAD SIZE		ROD EXTENSIONS AND PILOT DIMENSIONS										ADD STROKE					
		KK	FF	A	+000 -002 B	C	D	NA	FA	RD	VB	WF	Y	XG	XI MIN.	XC	XJ	ZB	ZC
1 1/2	5/8	7/16-20	1/2-20	3/4	1.124	3/8	1/2	9/16	3/8	2	5/8	1	2	1 1/8	3 3/4	6 3/8	4 7/8	6	6 7/8
	1	3/4-16	7/8-14	1 1/8	1.499	1/2	7/8	15/16	3/8	—	7/8	1 3/8	2 3/8	2 1/4	4 1/8	6 3/4	5 1/4	6 3/8	7 1/4
2	1	3/4-16	7/8-14	1 1/8	1.499	1/2	7/8	15/16	3/8	2 3/4	7/8	1 3/8	2 1/16	2 1/4	4 1/4	7 1/4	5 1/4	6 7/16	8
	1 3/8	1-14	1 1/4-12	1 5/8	1.999	5/8	1 1/8	1 5/16	5/8	—	1	1 5/8	2 1/16	2 1/2	4 1/2	7 1/2	5 1/2	6 11/16	8 1/4
2 1/2	1	3/4-16	7/8-14	1 1/8	1.499	1/2	7/8	15/16	3/8	2 3/4	7/8	1 3/8	2 1/16	2 1/4	4 1/4	7 3/8	5 3/8	6 9/16	8 1/8
	1 3/4	1 1/4-12	1 1/2-12	2	2.374	3/4	1 1/2	1 11/16	5/8	—	1 1/8	1 7/8	2 15/16	2 3/4	4 3/4	7 7/8	5 7/8	7 1/16	8 5/8
3 1/4	1 3/8	1-14	1 1/4-12	1 5/8	1.999	5/8	1 1/8	1 5/16	5/8	3 1/4	1	1 5/8	2 1/16	2 1/2	4 1/2	7 3/8	5 5/8	6 13/16	8 3/8
	2	1 1/2-12	1 3/4-12	2 1/4	2.624	7/8	1 11/16	1 15/16	5/8	4 1/8	1 1/8	2	3 1/8	3	5 3/8	8 3/8	6 1/4	7 11/16	9 5/8
4	1 3/4	1 1/4-12	1 1/2-12	2	2.374	3/4	1 1/2	1 11/16	5/8	3 3/4	1 1/8	1 7/8	3	2 1/8	5 1/4	8 3/8	6 1/2	7 15/16	9 7/8
	2 1/2	1 7/8-12	2 1/4-12	3	3.124	1	2 1/16	2 3/8	5/8	4 1/2	1 1/4	2 1/4	3 3/8	3 1/4	5 5/8	10 1/8	7 7/8	8 9/16	11 1/2
5	2	1 1/2-12	1 3/4-12	2 1/4	2.624	7/8	1 11/16	1 15/16	5/8	4 1/8	1 1/8	2	3 1/8	3	5 3/8	9 3/8	6 3/8	8 5/16	11 1/4
	2 1/2	1 7/8-12	2 1/4-12	3	3.124	1	2 1/16	2 3/8	5/8	4 1/2	1 1/4	2 1/4	3 3/8	3 1/4	5 5/8	10 1/8	7 7/8	8 9/16	11 1/2
6	3 1/2	2 1/2-12	3 1/4-12	3 1/2	4.249	1	3	3 3/8	5/8	5 1/2	1 1/4	2 1/4	3 3/8	3 1/4	5 11/16	10 3/4	7 5/8	9 5/16	12 1/2
	2 1/2	1 7/8-12	2 1/4-12	3	3.124	1	2 1/16	2 3/8	5/8	4 1/2	1 1/4	2 1/4	3 3/8	3 1/4	5 5/8	10 1/8	7 7/8	8 9/16	11 1/2
7	3	2 1/4-12	2 3/4-12	3 1/2	3.749	1	2 5/8	2 7/8	5/8	5 1/4	1 1/4	2 1/4	3 3/8	3 1/4	5 11/16	10 3/4	7 5/8	9 5/16	12 1/2
	2 1/2	1 7/8-12	2 1/4-12	3	3.124	1	2 1/16	2 3/8	5/8	4 1/2	1 1/4	2 1/4	3 3/16	3 3/8	5 5/16	12 1/8	8 3/8	10 9/16	14 1/8
8	4	3-12	3 3/4-12	4	4.749	1	3 3/8	3 7/8	3/4	6	1 1/4	2 1/4	3 1/16	3 3/8	5 5/16	12 1/8	8 3/8	10 9/16	14 1/8
	3	2 1/4-12	2 3/4-12	3 1/2	3.749	1	2 5/8	2 7/8	5/8	5 1/4	1 1/4	2 1/4	3 1/16	3 3/8	5 5/16	12 1/8	8 3/8	10 9/16	14 1/8
9	3 1/2	2 1/2-12	3 1/4-12	3 1/2	4.249	1	3	3 3/8	5/8	5 1/2	1 1/4	2 1/4	3 3/16	3 3/8	5 5/16	12 1/8	8 3/8	10 9/16	14 1/8
	4	3-12	3 3/4-12	4	4.749	1	3 3/8	3 7/8	3/4	6	1 1/4	2 1/4	3 1/16	3 3/8	5 5/16	12 1/8	8 3/8	10 9/16	14 1/8
10	3 1/2	2 1/2-12	3 1/4-12	3 1/2	4.249	1	3	3 3/8	5/8	5 1/2	1 1/4	2 1/4	3 3/8	3 1/4	5 11/16	10 3/4	7 5/8	9 5/16	12 1/2
	4 1/2	3 1/4-12	4 1/4-12	4 1/2	5.249	1	3 7/8	4 3/8	3/4	6 7/8	1 1/4	2 1/4	3 3/4	3 3/8	5 11/16	10 3/4	7 5/8	9 5/16	12 1/2
11	3 1/2	2 1/2-12	3 1/4-12	3 1/2	4.249	1	3	3 3/8	5/8	5 1/2	1 1/4	2 1/4	3 3/8	3 1/4	5 5/16	15	10 1/4	12 7/8	17 3/4
	5 1/2	4-12	5 1/4-12	5 1/2	6.249	1	4 5/8	5 3/8	3/4	8	1 1/4	2 1/4	3 3/8	3 1/4	5 5/16	15	10 1/4	12 7/8	17 3/4
12	4	3-12	3 3/4-12	4	4.749	1	3 3/8	3 7/8	3/4	6	1 1/4	2 1/4	3 3/8	3 1/4	5 5/16	15	10 1/4	12 7/8	17 3/4
	4 1/2	3 1/4-12	4 1/4-12	4 1/2	5.249	1	3 7/8	4 3/8	3/4	6 7/8	1 1/4	2 1/4	3 3/8	3 1/4	5 5/16	15	10 1/4	12 7/8	17 3/4
13	5	3 1/2-12	4 3/4-12	5	5.749	1	4 1/4	4 7/8	3/4	7 1/4	1 1/4	2 1/4	3 3/8	3 1/4	5 5/16	15	10 1/4	12 7/8	17 3/4
	5 1/2	3 1/2-12	4 3/4-12	5	5.749	1	4 1/4	4 7/8	3/4	7 1/4	1 1/4	2 1/4	3 3/8	3 1/4	5 5/16	15	10 1/4	12 7/8	17 3/4

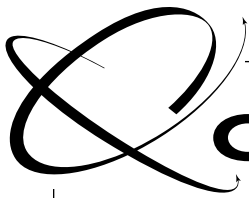

Quincy
PORTMAN CYLINDERS

Series 3TH Flange Mounted Cylinders 1.50" to 8.00"

**STYLE B—Rectangular
Flange Mount Head End**
(NFPA Mounting Style MF1)

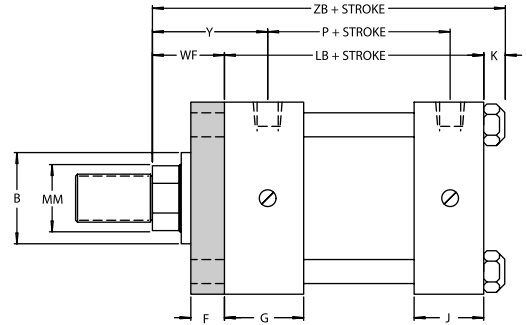
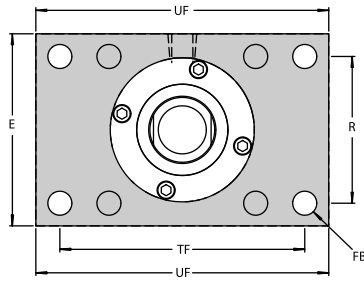

**STYLE A—Rectangular
Flange Mount Cap End**
(NFPA Mounting Style MF2)

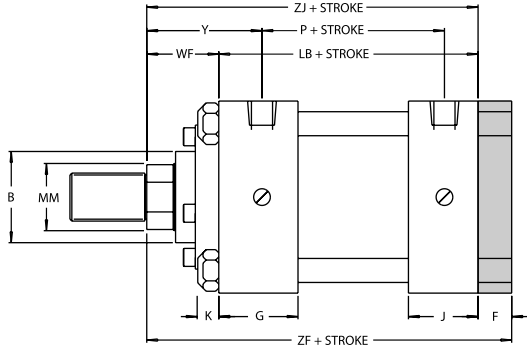
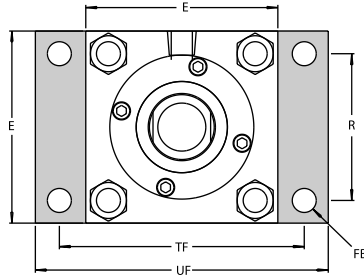

**STYLE BB—Square Flange
Mount Head End**
(NFPA Mounting Style MF5)

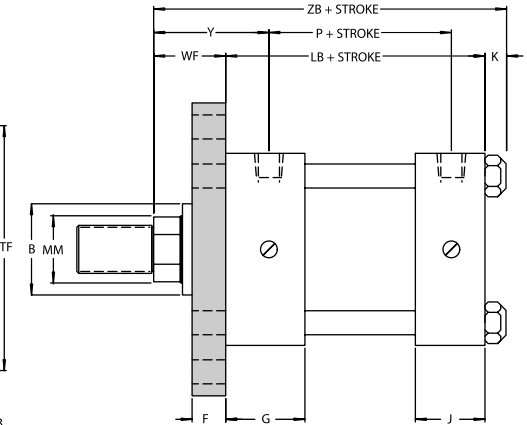
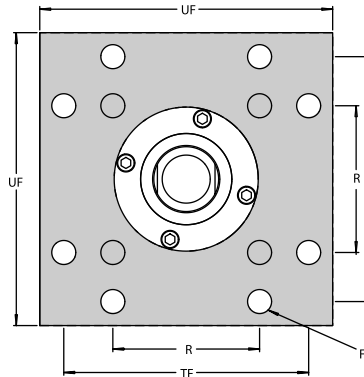

**STYLE AA—Square Flange
Mount Cap End**
(NFPA Mounting Style MF6)

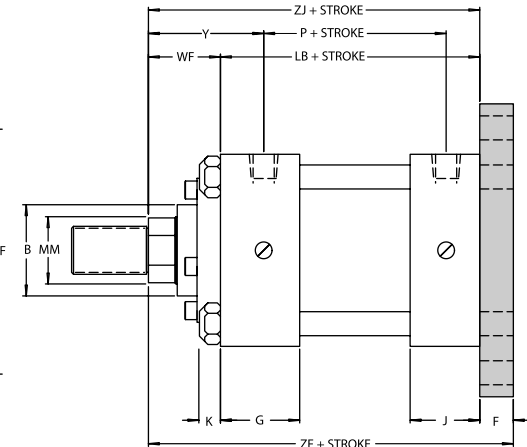
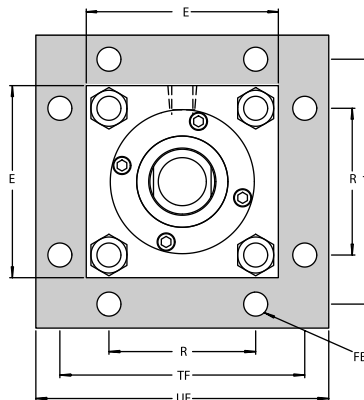

**Series 3TH
Section 3**

ENVELOPE AND MOUNTING DIMENSIONS

BORE	E	EE		F	FB*	G	J	K	R	TF	UF	ADD STROKE	
		NPTF	SAE									LF	P
1½	2½	½	8	⅜	⅜	1 ²⁷ / ₃₂	1 ¹⁹ / ₃₂	⅜	1.63	3 ⁷ / ₁₆	4¼	5	2 ⁷ / ₈
2	3	½	8	⅝	½	1 ²⁷ / ₃₂	1 ¹⁹ / ₃₂	7 ¹⁶ / ₁₆	2.05	4 ¹ / ₈	5 ¹ / ₈	5¼	2 ¹³ / ₁₆
2½	3½	½	8	⅝	½	1 ²⁷ / ₃₂	1 ¹⁹ / ₃₂	7 ¹⁶ / ₁₆	2.55	4 ⁵ / ₈	5 ⁵ / ₈	5 ³ / ₈	2 ¹⁵ / ₁₆
3¼	4½	¾	12	¾	⅝	2 ¹ / ₁₆	1 ¹³ / ₁₆	9 ¹⁶ / ₁₆	3.25	5 ⁷ / ₈	7 ¹ / ₈	6¼	3½
4	5	¾	12	7 ⁸ / ₈	⅝	2 ¹ / ₁₆	1 ¹³ / ₁₆	9 ¹⁶ / ₁₆	3.82	6 ³ / ₈	7 ⁵ / ₈	6 ⁵ / ₈	3¾
5	6½	¾	12	7 ⁸ / ₈	7 ⁸ / ₈	2 ¹ / ₈	1 ⁷ / ₈	13 ¹⁶ / ₁₆	4.95	8 ³ / ₁₆	9¾	7 ¹ / ₈	4¼
6	7½	1	16	1	1	2¼	2¼	15 ¹⁶ / ₁₆	5.73	9 ⁷ / ₁₆	11¼	8 ³ / ₈	5
7	8½	1¼	20	1	1½	2¾	2¾	1	6.58	10 ⁵ / ₈	12 ⁵ / ₈	9½	5½
8	9½	1½	24	1	1¼	3	3	1½	7.50	11 ¹³ / ₁₆	14	10½	6¼

Head end cushions are non-available on 1½"-2"-2½" bore cylinders with max. size rods. NPTF ports furnished as standard unless otherwise specified. SAE straight thread ports optional.

*Mounting holes are 1/16 larger than screw size shown.

ENVELOPE AND MOUNTING DIMENSIONS

ROD END DIMENSIONS										ENVELOPE AND MOUNTING DIMENSIONS							
BORE	ROD DIA. MM	THREAD SIZE		ROD EXTENSIONS AND PILOT DIMENSIONS								ADD STROKE					
		KK	FF	A	+000 -002 B	C	D	NA	FA	RD	VB	WF	Y	W	ZJ	ZB	ZF
1½	5/8*	7/16-20	1/2-20	¾	1.124	⅜	½	9/16	⅜	2	5/8	1	2	5/8	5 ⁷ / ₈	6	6
	1*	¾-16	7/8-14	1/8	1.499	½	7/8	15/16	⅜	—	7/8	1 ³ / ₈	2 ³ / ₈	1	6	6 ³ / ₈	6 ³ / ₈
2	1*	¾-16	7/8-14	1/8	1.499	½	7/8	15/16	⅜	2¾	7/8	1 ³ / ₈	2 ⁷ / ₁₆	¾	6	6 ⁷ / ₁₆	6 ⁶ / ₈
	1¾*	1-14	1¼-12	15/8	1.999	5/8	1½	15/16	5/8	—	1	15/8	2 ¹¹ / ₁₆	1	6¼	6 ¹¹ / ₁₆	6 ⁶ / ₈
2½	1*	¾-16	7/8-14	1/8	1.499	½	7/8	15/16	⅜	2¾	7/8	1 ³ / ₈	2 ⁷ / ₁₆	¾	6 ¹ / ₈	6 ⁹ / ₁₆	6 ⁴ / ₄
	1¾*	1¼-12	1½-12	2	2.374	¾	1½	11 ¹¹ / ₁₆	5/8	—	1½	1 ⁷ / ₈	2 ¹⁵ / ₁₆	1¼	6 ⁵ / ₈	7 ¹ / ₁₆	7¼
	1¾*	1-14	1¼-12	15/8	1.999	5/8	1½	15/16	5/8	3¼	1	15/8	2 ¹¹ / ₁₆	1	6 ³ / ₈	6 ¹³ / ₁₆	7
3¼	1¾	1-14	1¼-12	15/8	1.999	5/8	1½	15/16	5/8	3¼	1	15/8	2¾	7/8	7 ¹ / ₈	7 ¹¹ / ₁₆	7 ⁷ / ₈
	2*	1½-12	1¾-12	2¼	2.624	7/8	11 ¹¹ / ₁₆	15 ¹⁶ / ₁₆	5/8	4 ¹ / ₈	1½	2	3 ¹ / ₈	1¼	7½	8 ¹ / ₁₆	8¼
	1¾*	1¼-12	1½-12	2	2.374	¾	1½	11 ¹¹ / ₁₆	5/8	3¾	1½	1 ⁷ / ₈	3	1½	7 ³ / ₈	7 ¹⁵ / ₁₆	8 ⁸ / ₈
4	1¾	1¼-12	1½-12	2	2.374	¾	1½	11 ¹¹ / ₁₆	5/8	3¾	1½	1 ⁷ / ₈	3	1	7 ³ / ₈	8 ³ / ₁₆	8½
	2½*	1½-12	2¼-12	3	3.124	1	2 ¹ / ₁₆	2 ³ / ₈	5/8	4½	1¼	2¼	3 ³ / ₈	1 ³ / ₈	8	8 ⁹ / ₁₆	8 ⁸ / ₈
	2	1½-12	1¾-12	2¼	2.624	7/8	11 ¹¹ / ₁₆	15 ¹⁶ / ₁₆	5/8	4 ¹ / ₈	1½	2	3 ¹ / ₈	1½	7¾	8 ⁵ / ₁₆	8 ⁸ / ₈
5	2	1½-12	1¾-12	2¼	2.624	7/8	11 ¹¹ / ₁₆	15 ¹⁶ / ₁₆	5/8	4 ¹ / ₈	1½	2	3 ¹ / ₈	1½	8¼	9 ¹ / ₁₆	9 ⁸ / ₈
	3½	2½-12	3¼-12	3½	4.249	1	3	3 ³ / ₈	5/8	5½	1¼	2¼	3 ³ / ₈	1 ³ / ₈	8½	9 ⁵ / ₁₆	9 ⁸ / ₈
	2½	1½-12	2¼-12	3	3.124	1	2 ¹ / ₁₆	2 ³ / ₈	5/8	4½	1¼	2¼	3 ³ / ₈	1 ³ / ₈	8½	9 ⁵ / ₁₆	9 ⁸ / ₈
	3	2¼-12	2¾-12	3½	3.749	1	2 ⁵ / ₈	2 ⁷ / ₈	5/8	5¼	1¼	2¼	3 ³ / ₈	1 ³ / ₈	8½	9 ⁵ / ₁₆	9 ⁸ / ₈
6	2½	1½-12	2¼-12	3	3.124	1	2 ¹ / ₁₆	2 ³ / ₈	5/8	4½	1¼	2¼	3 ⁷ / ₁₆	1¼	9 ⁵ / ₈	10 ⁹ / ₁₆	10 ⁵ / ₈
	4	3-12	3¼-12	4	4.749	1	3 ³ / ₈	3 ³ / ₈	¾	6	1¼	2¼	3 ⁷ / ₁₆	1¼	9 ⁵ / ₈	10 ⁹ / ₁₆	10 ⁵ / ₈
	3	2¼-12	2¾-12	3½	3.749	1	2 ⁵ / ₈	2 ⁷ / ₈	5/8	5¼	1¼	2¼	3 ⁷ / ₁₆	1¼	9 ⁵ / ₈	10 ⁹ / ₁₆	10 ⁵ / ₈
	3½	2½-12	3¼-12	3½	4.249	1	3	3 ³ / ₈	5/8	5½	1¼	2¼	3 ⁷ / ₁₆	1¼	9 ⁵ / ₈	10 ⁹ / ₁₆	10 ⁵ / ₈
7	3	2¼-12	2¾-12	3½	3.749	1	2 ⁵ / ₈	2 ⁷ / ₈	5/8	5¼	1¼	2¼	3¾	1¼	10 ³ / ₄	11 ³ / ₄	11 ³ / ₄
	5	3½-12	4¾-12	5	5.749	1	4¼	4 ⁷ / ₈	¾	7¼	1¼	2¼	3¾	1¼	10 ³ / ₄	11 ³ / ₄	11 ³ / ₄
	3½	2½-12	3¼-12	3½	4.249	1	3	3 ³ / ₈	5/8	5½	1¼	2¼	3¾	1¼	10 ³ / ₄	11 ³ / ₄	11 ³ / ₄
	4	3-12	3¼-12	4	4.749	1	3 ³ / ₈	3 ³ / ₈	¾	6	1¼	2¼	3¾	1¼	10 ³ / ₄	11 ³ / ₄	11 ³ / ₄
	4½	3¼-12	4¼-12	4½	5.249	1	3 ⁷ / ₈	4 ⁷ / ₈	¾	6 ⁷ / ₈	1¼	2¼	3¾	1¼	10 ³ / ₄	11 ³ / ₄	11 ³ / ₄
8	3½	2½-12	3¼-12	3½	4.249	1	3	3 ³ / ₈	5/8	5½	1¼	2¼	3 ⁷ / ₈	1¼	11 ³ / ₄	12 ⁷ / ₈	12 ³ / ₄
	5½	4-12	5¼-12	5½	6.249	1	4 ⁵ / ₈	5 ⁵ / ₈	¾	8	1¼	2¼	3 ⁷ / ₈	1¼	11 ³ / ₄	12 ⁷ / ₈	12 ³ / ₄
	4	3-12	3¼-12	4	4.749	1	3 ³ / ₈	3 ³ / ₈	¾	6	1¼	2¼	3 ⁷ / ₈	1¼	11 ³ / ₄	12 ⁷ / ₈	12 ³ / ₄
	4½	3¼-12	4¼-12	4½	5.249	1	3 ⁷ / ₈	4 ⁷ / ₈	¾	6 ⁷ / ₈	1¼	2¼	3 ⁷ / ₈	1¼	11 ³ / ₄	12 ⁷ / ₈	12 ³ / ₄
5	3½-12	4¾-12	5	5.749	1	4¼	4 ⁷ / ₈	¾	7¼	1¼	2¼	3 ⁷ / ₈	1¼	11 ³ / ₄	12 ⁷ / ₈	12 ³ / ₄	

Styles A and B, particularly those above the 4" bore size, are not recommended for maximum operating pressures. For operating pressures above 1500 psi on the 5" and 6" bore cylinders, and 1000 psi on the 7" and 8" bore cylinders, we recommend the use of styles AA and BB. Maximum operating pressure for AA and BB style flanges, in bores 5" thru 8", should not exceed 3000 psi. We recommend the use of high tensile mounting bolts on all flange mounted cylinders subjected to maximum pressures and shock loads.

*These bore and rod combinations use the flange to retain the bearing on "B" and "BB" mounts.

Series 3TH

Heavy Duty Flange Mounted Cylinders

1.50" to 8.00"

Series 3TH
Section 3

STYLE Q—Rectangular Head End Mount
(NFPA Mounting Style ME5)

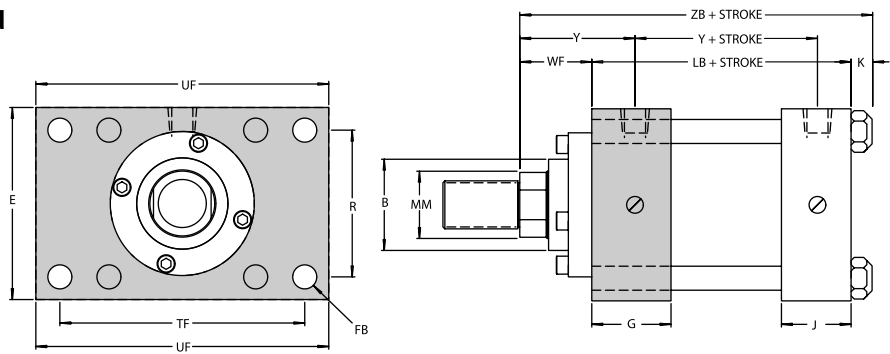

STYLE P—Rectangular Cap End Mount
(NFPA Mounting Style ME6)

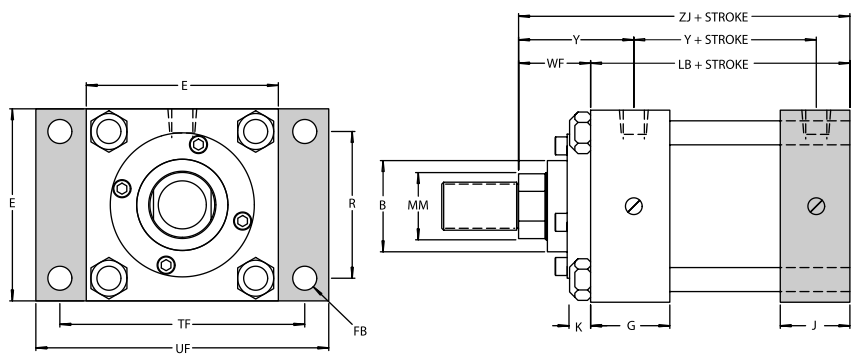

ENVELOPE AND MOUNTING DIMENSIONS

BORE	E	EE		FB*	G	J	K	R	TF	UF	ADD STROKE	
		NPTF	SAE								LB	P
1½	2½	½	8	⅜	1 ²⁷ / ₃₂	1 ¹⁹ / ₃₂	⅜	1.63	3 ⁷ / ₁₆	4¼	4 ⁵ / ₈	2 ⁷ / ₈
2	3	½	8	½	1 ²⁷ / ₃₂	1 ¹⁹ / ₃₂	7 ⁷ / ₁₆	2.05	4 ¹ / ₈	5 ¹ / ₈	4 ⁵ / ₈	2 ¹³ / ₁₆
2½	3½	½	8	½	1 ²⁷ / ₃₂	1 ¹⁹ / ₃₂	7 ⁷ / ₁₆	2.55	4 ⁵ / ₈	5 ⁵ / ₈	4¾	2 ¹⁵ / ₁₆
3¼	4½	¾	12	5 ⁵ / ₈	2 ¹ / ₁₆	1 ¹³ / ₁₆	9 ⁹ / ₁₆	3.25	5 ⁷ / ₈	7 ¹ / ₈	5½	3½
4	5	¾	12	5 ⁵ / ₈	2 ¹ / ₁₆	1 ¹³ / ₁₆	9 ⁹ / ₁₆	3.82	6 ³ / ₈	7 ⁵ / ₈	5¾	3¾
5	6½	¾	12	7 ⁷ / ₈	2 ¹ / ₈	1 ⁷ / ₈	13 ¹³ / ₁₆	4.95	8 ³ / ₁₆	9¾	6¼	4¼
6	7½	1	16	1	2¼	2¼	15 ¹⁵ / ₁₆	5.73	9 ⁹ / ₁₆	11¼	7 ³ / ₈	5
7	8½	1¼	20	1 ¹ / ₈	2¾	2¾	1	6.58	10 ⁵ / ₈	12 ⁵ / ₈	8½	5½
8	9½	1½	24	1¼	3	3	1 ¹ / ₈	7.50	11 ¹³ / ₁₆	14	9½	6¼

Head end cushions are non-available on 1½"-2"-2½" bore cylinders with max. size rods. NPTF ports furnished as standard unless otherwise specified. SAE straight thread ports optional.

*Mounting holes are 1/16 larger than screw size shown.

ENVELOPE AND MOUNTING DIMENSIONS

ROD END DIMENSIONS

BORE	ROD DIA. MM	THREAD SIZE		ROD EXTENSIONS AND PILOT DIMENSIONS								ADD STROKE			
		KK	FF	A	+000 -002 B	C	D	NA	FA	RD	VB	WF	Y	ZJ	ZB
1½	5/8	7/16-20	1/2-20	3/4	1.124	3/8	1/2	9/16	3/8	2	5/8	1	2	5 ⁵ / ₈	6
	1	3/4-16	7/8-14	1 ¹ / ₈	1.499	1/2	7/8	15 ¹⁵ / ₁₆	3/8	—	7/8	1 ³ / ₈	2 ³ / ₈	6	6 ³ / ₈
2	1	3/4-16	7/8-14	1 ¹ / ₈	1.499	1/2	7/8	15 ¹⁵ / ₁₆	3/8	2 ³ / ₄	7/8	1 ³ / ₈	2 ⁷ / ₁₆	6	6 ⁷ / ₁₆
	1 ³ / ₈	1-14	1¼-12	1 ⁵ / ₈	1.999	5/8	1 ¹ / ₈	1 ⁵ / ₁₆	5/8	—	1	1 ⁵ / ₈	2 ¹ / ₁₆	6¼	6 ¹¹ / ₁₆
2½	1	3/4-16	7/8-14	1 ¹ / ₈	1.499	1/2	7/8	15 ¹⁵ / ₁₆	3/8	2 ³ / ₄	7/8	1 ³ / ₈	2 ⁷ / ₁₆	6 ¹ / ₈	6 ⁹ / ₁₆
	1 ³ / ₄	1¼-12	1½-12	2	2.374	3/4	1½	1 ¹¹ / ₁₆	5/8	—	1 ¹ / ₈	1 ⁷ / ₈	2 ¹⁵ / ₁₆	6 ⁵ / ₈	7 ¹ / ₁₆
	1 ³ / ₈	1-14	1¼-12	1 ⁵ / ₈	1.999	5/8	1 ¹ / ₈	1 ⁵ / ₁₆	5/8	3¼	1	1 ⁵ / ₈	2 ¹ / ₁₆	6 ³ / ₈	6 ¹³ / ₁₆
3¼	1 ³ / ₈	1-14	1¼-12	1 ⁵ / ₈	1.999	5/8	1 ¹ / ₈	1 ⁵ / ₁₆	5/8	3¼	1	1 ⁵ / ₈	2 ³ / ₄	7 ¹ / ₈	7 ¹¹ / ₁₆
	2	1½-12	1¾-12	2¼	2.624	7/8	1 ¹¹ / ₁₆	1 ¹⁵ / ₁₆	5/8	4 ¹ / ₈	1 ¹ / ₈	2	3 ¹ / ₈	7½	8 ¹ / ₁₆
	1 ³ / ₄	1¼-12	1½-12	2	2.374	3/4	1½	1 ¹¹ / ₁₆	5/8	3¼	1 ¹ / ₈	1 ⁷ / ₈	3	7 ³ / ₈	7 ¹⁵ / ₁₆
4	1 ³ / ₄	1¼-12	1½-12	2	2.374	3/4	1½	1 ¹¹ / ₁₆	5/8	3¼	1 ¹ / ₈	1 ⁷ / ₈	3	7 ³ / ₈	8 ³ / ₁₆
	2½	1 ⁷ / ₈ -12	2¼-12	3	3.124	1	2 ¹ / ₁₆	2 ³ / ₈	5/8	4½	1¼	2¼	3 ³ / ₈	8	8 ⁹ / ₁₆
	2	1½-12	1¾-12	2¼	2.624	7/8	1 ¹¹ / ₁₆	1 ¹⁵ / ₁₆	5/8	4 ¹ / ₈	1 ¹ / ₈	2	3 ¹ / ₈	7¾	8 ⁵ / ₁₆
5	2	1½-12	1¾-12	2¼	2.624	7/8	1 ¹¹ / ₁₆	1 ¹⁵ / ₁₆	5/8	4 ¹ / ₈	1 ¹ / ₈	2	3 ¹ / ₈	8¼	9 ¹ / ₁₆
	3½	2½-12	3¼-12	3½	4.249	1	3	3 ³ / ₈	5/8	5½	1¼	2¼	3 ³ / ₈	8½	9 ⁵ / ₁₆
	2½	1 ⁷ / ₈ -12	2¼-12	3	3.124	1	2 ¹ / ₁₆	2 ³ / ₈	5/8	4½	1¼	2¼	3 ³ / ₈	8½	9 ⁵ / ₁₆
6	3	2¼-12	2¾-12	3½	3.749	1	2 ⁵ / ₈	2 ⁷ / ₈	5/8	5¼	1¼	2¼	3 ³ / ₈	8½	9 ⁵ / ₁₆
	2½	1 ⁷ / ₈ -12	2¼-12	3	3.124	1	2 ¹ / ₁₆	2 ³ / ₈	5/8	4½	1¼	2¼	3 ⁷ / ₁₆	9 ⁵ / ₈	10 ⁹ / ₁₆
	4	3-12	3¾-12	4	4.749	1	3 ³ / ₈	3 ⁷ / ₈	¾	6	1¼	2¼	3 ⁷ / ₁₆	9 ⁵ / ₈	10 ⁹ / ₁₆
7	3	2¼-12	2¾-12	3½	3.749	1	2 ⁵ / ₈	2 ⁷ / ₈	5/8	5¼	1¼	2¼	3 ³ / ₄	10 ³ / ₄	11 ³ / ₄
	5	3½-12	4¾-12	5	5.749	1	4¼	4 ⁷ / ₈	¾	7¼	1¼	2¼	3 ³ / ₄	10 ³ / ₄	11 ³ / ₄
	3½	2½-12	3¼-12	3½	4.249	1	3	3 ³ / ₈	5/8	5½	1¼	2¼	3 ³ / ₄	10 ³ / ₄	11 ³ / ₄
	4	3-12	3¾-12	4	4.749	1	3 ³ / ₈	3 ⁷ / ₈	¾	6	1¼	2¼	3 ³ / ₄	10 ³ / ₄	11 ³ / ₄
8	4½	3¼-12	4¼-12	4½	5.249	1	3 ³ / ₈	4 ³ / ₈	¾	6 ⁷ / ₈	1¼	2¼	3 ³ / ₄	10 ³ / ₄	11 ³ / ₄
	3½	2½-12	3¼-12	3½	4.249	1	3	3 ³ / ₈	5/8	5½	1¼	2¼	3 ⁷ / ₈	11 ³ / ₄	12 ⁷ / ₈
	5½	4-12	5¼-12	5½	6.249	1	4 ⁵ / ₈	5 ³ / ₈	¾	8	1¼	2¼	3 ⁷ / ₈	11 ³ / ₄	12 ⁷ / ₈
	4	3-12	3¾-12	4	4.749	1	3 ³ / ₈	3 ⁷ / ₈	¾	6	1¼	2¼	3 ⁷ / ₈	11 ³ / ₄	12 ⁷ / ₈

Series 3TH

Foot Mounted Cylinders

10.00" to 14.00"

Series 3TH
Section 3

STYLE K—Center Line Mount
(NFPA Mounting Style MS3)

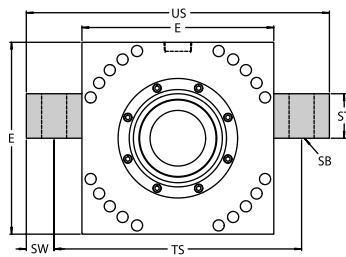

STYLE J—Side Lug Mount
(NFPA Mounting Style MS2)

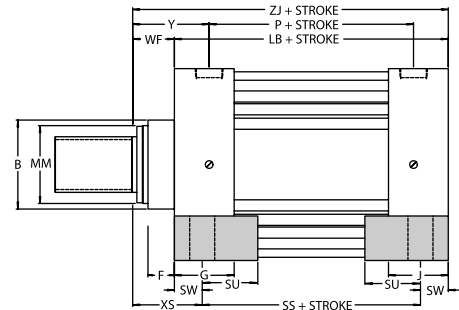
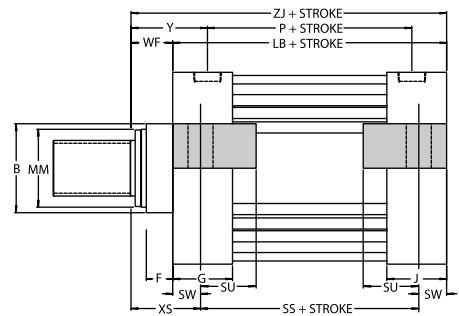
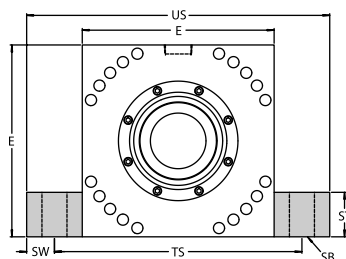

ENVELOPE AND MOUNTING DIMENSIONS

BORE	E	EE	F	G	J	SB*	ST	SU	SW	TS	US	ADD STROKE		
												LB	P	SS
10	12 ⁵ / ₈	2	1 ¹¹ / ₁₆	3 ¹¹ / ₁₆	3 ¹¹ / ₁₆	1 ¹ / ₂	2 ¹ / ₄	3 ¹ / ₂	1 ⁵ / ₈	15 ⁷ / ₈	19 ¹ / ₈	12 ¹ / ₈	8 ¹ / ₂	8 ⁷ / ₈
12	14 ⁷ / ₈	2 ¹ / ₄	1 ¹⁵ / ₁₆	4 ⁷ / ₁₆	4 ⁷ / ₁₆	1 ¹ / ₂	3	4 ¹ / ₄	2	18 ⁷ / ₈	22 ⁷ / ₈	14 ¹ / ₂	10 ¹ / ₈	10 ¹ / ₂
14	17 ¹ / ₄	2 ¹ / ₂	2 ³ / ₈	5 ³ / ₈	5 ³ / ₈	2 ¹ / ₄	4	5	2 ¹ / ₂	22 ¹ / ₄	27 ¹ / ₄	16 ⁵ / ₈	10 ³ / ₈	11 ⁵ / ₈

NPTF ports furnished as std. unless otherwise specified.

*Mounting holes are 1/16" larger than screw size shown. Styles J and K should be pinned or keyed to prevent shifting at one end only.

ROD END DIMENSIONS

ENVELOPE AND MOUNTING DIMENSIONS

BORE	ROD DIA.	THREAD SIZE		ROD EXTENSIONS AND PILOT DIMENSIONS							WF	Y	XS	ADD STR.	ADD 2X STR.
	MM	KK	FF	A	+000 -002 B	C	D	NA	RD	V				ZJ	ZM
10	4 ¹ / ₂	3 ¹ / ₄ -12	4 ¹ / ₄ -12	4 ¹ / ₂	5.249	1	3 ⁷ / ₈	4 ³ / ₈	8	1 ¹ / ₄	2 ¹⁵ / ₁₆	4 ³ / ₄	4 ⁹ / ₁₆	15 ¹ / ₁₆	18
	7	5-12	6 ³ / ₄ -12	7	7.999	1	—	6 ⁷ / ₈	10 ³ / ₄	1 ¹ / ₂	3 ³ / ₁₆	5	4 ¹³ / ₁₆	15 ⁵ / ₁₆	18 ¹ / ₂
	5	3 ¹ / ₂ -12	4 ³ / ₄ -12	5	5.749	1	4 ¹ / ₄	4 ⁷ / ₈	8 ¹ / ₂	1 ¹ / ₄	2 ¹⁵ / ₁₆	4 ³ / ₄	4 ⁹ / ₁₆	15 ¹ / ₁₆	18
	5 ¹ / ₂	4-12	5 ¹ / ₄ -12	5 ¹ / ₂	6.249	1	4 ⁵ / ₈	5 ³ / ₈	9	1 ¹ / ₂	3 ³ / ₁₆	5	4 ¹³ / ₁₆	15 ⁵ / ₁₆	18 ¹ / ₂
12	5 ¹ / ₂	4-12	5 ¹ / ₄ -12	5 ¹ / ₂	6.249	1	4 ⁵ / ₈	5 ³ / ₈	9	1 ¹ / ₄	3 ³ / ₁₆	5 ³ / ₈	5 ³ / ₁₆	17 ¹¹ / ₁₆	20 ⁷ / ₈
	8 ¹ / ₂	6-12	8 ³ / ₄ -12	8 ¹ / ₂	9.499	1	—	8 ³ / ₈	12 ³ / ₄	1 ¹ / ₂	3 ⁷ / ₁₆	5 ⁵ / ₈	5 ⁷ / ₁₆	17 ¹⁵ / ₁₆	21 ³ / ₈
	7	5-12	6 ³ / ₄ -12	7	7.999	1	—	6 ⁷ / ₈	10 ³ / ₄	3 ³ / ₈	3 ⁵ / ₁₆	5 ¹ / ₂	5 ⁵ / ₁₆	17 ¹³ / ₁₆	21 ¹ / ₈
14	7	5-12	6 ³ / ₄ -12	7	7.999	1	—	6 ⁷ / ₈	10 ³ / ₄	3 ³ / ₈	3 ³ / ₄	6 ⁷ / ₈	6 ¹ / ₄	20 ³ / ₈	24 ¹ / ₈
	10	7-12	9 ³ / ₄ -12	10	10.999	1	—	9 ⁷ / ₈	14 ¹ / ₄	1 ¹ / ₂	3 ⁷ / ₈	7	6 ³ / ₈	20 ¹ / ₂	24 ³ / ₈
	8 ¹ / ₂	6-12	8 ³ / ₄ -12	8 ¹ / ₂	9.499	1	—	8 ³ / ₈	12 ³ / ₄	1 ¹ / ₂	3 ⁷ / ₈	7	6 ³ / ₈	20 ¹ / ₂	24 ³ / ₈

Double Rod Cylinder

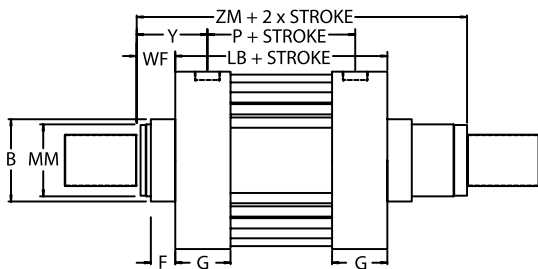

ENVELOPE DIMENSIONS

BORE	AA	DD	E	EE	F	G	ADD STROKE	
							LB	P
10	12 ⁷ / ₈	1-14	12 ⁵ / ₈	2	1 ¹¹ / ₁₆	3 ¹¹ / ₁₆	12 ¹ / ₈	8 ¹ / ₂
12	15 ¹ / ₁₆	1-14	14 ⁷ / ₈	2 ¹ / ₂	1 ¹⁵ / ₁₆	4 ⁷ / ₁₆	14 ¹ / ₂	10 ¹ / ₈
14	17 ⁵ / ₁₆	1-14	17 ¹ / ₄	2 ¹ / ₂	2 ³ / ₈	5 ³ / ₈	16 ⁵ / ₈	10 ³ / ₈

NPTF ports furnished as std. unless otherwise specified.

Double Rod Cylinder

Double Rod cylinders are available in all styles except A, AA, EB and G. Dimensions for other styles are same as above with mounting added. When ordering add prefix D to style. Example: DB HYD. CYL.

Series 3TH

Pivot Mounted Cylinders

10.00" to 14.00"

**STYLE ER—Trunnion
Mount Head End**
(NFPA Mounting Style MT1)

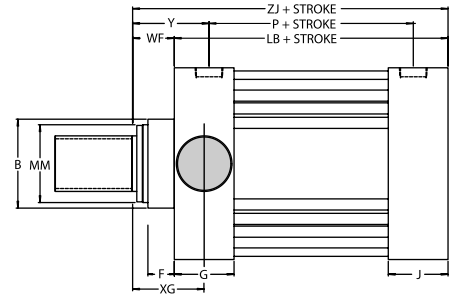
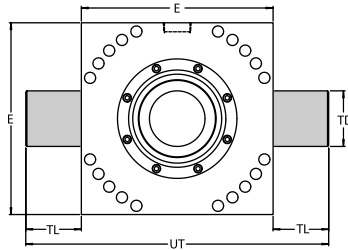

**STYLE EB—Trunnion
Mount Cap End**
(NFPA Mounting Style MT2)

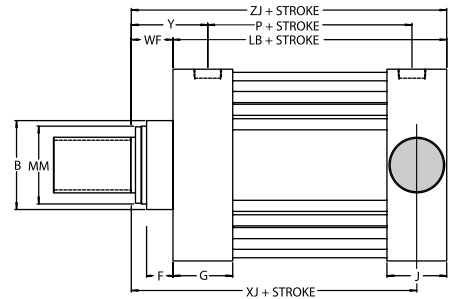
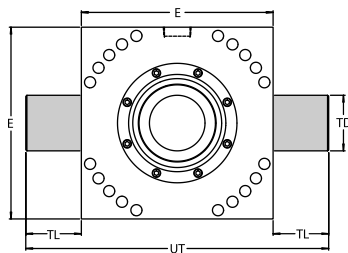

**STYLE E—Intermediate
Trunnion Mount**
(NFPA Mounting Style MT4)
Customer to specify
Trunnion location (XI dim.)

Cylinders with E, EB and ER in bores
10" thru 14" should not be used for
pressures in excess of 2000 psi.

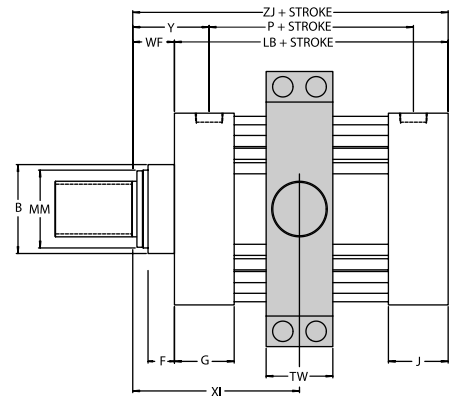
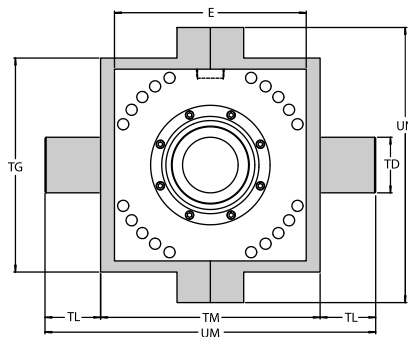

STYLE G—Clevis Mount
(NFPA Mounting Style MP1)

Chrome-plated Clevis Pin Assembly
(with Snap Rings) is furnished with all
Style G Cylinders.

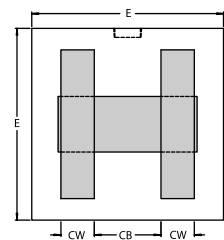
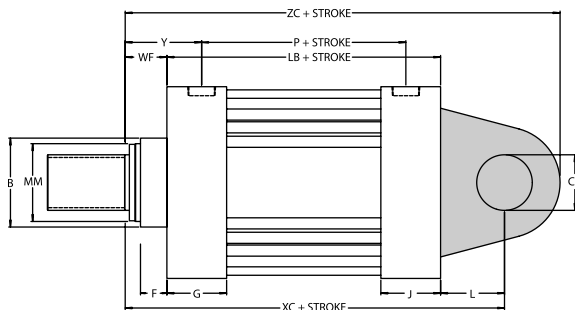

ENVELOPE AND MOUNTING DIMENSIONS

BORE	CB	±001 CD	CW	E	EE	F	G	J	L	LR	MR	+000 -001 TD	TL	TG	TM	TW	UM	UN	UT	ADD STROKE	
																				LB	P
10	4	3 1/2	2	12 5/8	2	1 11/16	3 11/16	3 11/16	4	3 5/8	3 1/2	3 1/2	3 1/2	13 1/2	14	4 1/2	21	17 1/2	19 5/8	12 1/8	8 1/2
12	4 1/2	4	2 1/4	14 7/8	2 1/2	1 15/16	4 7/16	4 7/16	4 1/2	4 1/8	4	4	4	16	16 1/2	5 1/2	24 1/2	20 3/4	22 7/8	14 1/2	10 1/8
14	6	5	3	17 1/4	2 1/2	2 3/8	5 3/8	5 3/8	5 3/4	5 1/8	5	5	5	19 1/4	19 3/4	6	29 3/4	24 3/4	27 1/4	16 5/8	10 3/8

NPTF ports furnished as standard unless otherwise specified. Pintles on trunnion mounted cylinders are designed to withstand shear loads, but not high bending loads. Pillow blocks must be rigidly mounted to provide full support with minimum clearances.

ROD END DIMENSIONS

**ENVELOPE AND
MOUNTING
DIMENSIONS**

BORE	ROD DIA.	THREAD SIZE		ROD EXTENSIONS AND PILOT DIMENSIONS							ADD STROKE							
		MM	KK	FF	A	+000 -002 B	C	D	NA	RD	V	WF	Y	XG	XI MIN.	XC	XJ	ZJ
10	4 1/2	3 1/4-12	4 1/4-12	4 1/2	5.249	1	3 7/8	4 3/8	8	1/4	2 15/16	4 3/4	4 3/4	9 9/16	19 1/16	13 1/4	15 1/16	22 9/16
	7	5-12	6 3/4-12	7	7.999	1	—	6 7/8	10 3/4	1/2	3 3/16	5	5	9 7/16	19 5/16	13 1/2	15 5/16	22 13/16
	5	3 1/2-12	4 3/4-12	5	5.749	1	4 1/4	4 7/8	8 1/2	1/4	2 15/16	4 3/4	4 3/4	9 9/16	19 1/16	13 1/4	15 1/16	22 9/16
	5 1/2	4-12	5 1/4-12	5 1/2	6.249	1	4 5/8	5 3/8	9	1/2	3 3/16	5	5	9 7/16	19 5/16	13 1/2	15 5/16	22 13/16
12	5 1/2	4-12	5 1/4-12	5 1/2	6.249	1	4 5/8	5 3/8	9	1/4	3 3/16	5 3/8	5 3/8	10 11/16	22 3/16	15 1/2	17 11/16	26 3/16
	8 1/2	6-12	8 1/4-12	8 1/2	9.499	1	—	8 3/8	12 3/4	1/2	3 7/16	5 5/8	5 5/8	10 15/16	22 7/16	15 3/4	17 15/16	26 7/16
	7	5-12	6 3/4-12	7	7.999	1	—	6 7/8	10 3/4	3/8	3 5/16	5 1/2	5 1/2	10 13/16	22 5/16	15 5/8	17 13/16	26 5/16
14	7	5-12	6 3/4-12	7	7.999	1	—	6 7/8	10 3/4	3/8	3 3/4	6 7/8	6 7/16	12 7/16	26 1/8	17 11/16	20 3/8	31 1/8
	10	7-12	9 3/4-12	10	10.999	1	—	9 7/8	14 1/4	1/2	3 7/8	7	6 9/16	12 9/16	26 1/4	17 13/16	20 1/2	31 1/4
	8 1/2	6-12	8 1/4-12	8 1/2	9.499	1	—	8 3/8	12 3/4	1/2	3 7/8	7	6 9/16	12 9/16	26 1/4	17 13/16	20 1/2	31 1/4

Series 3TH

Flange Mounted Cylinders

10.00" to 14.00"

**STYLE A—Rectangular
Flange Mount Cap End**
(NFPA Mounting Style MF2)

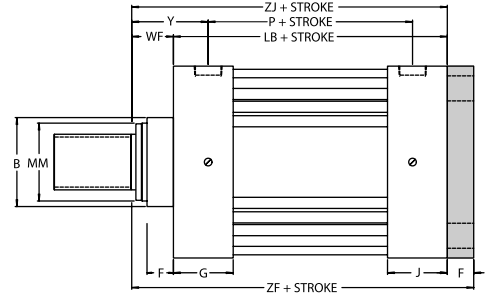
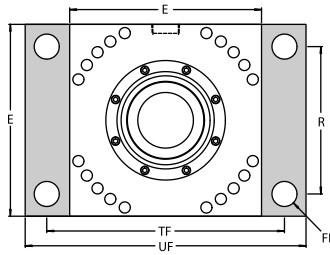

**STYLE AA—Square Flange
Mount Cap End**
(NFPA Mounting Style MF6)

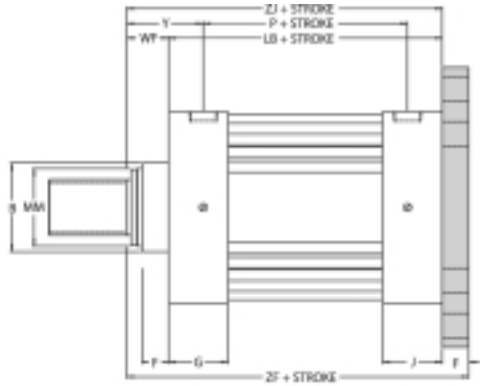
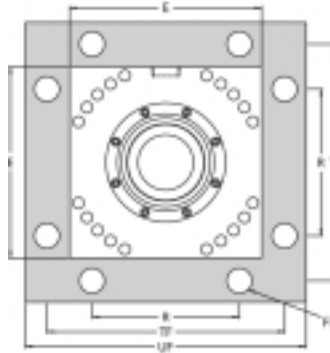

**STYLE B—Rectangular
Flange Mount Head End**
(NFPA Mounting Style MF1)

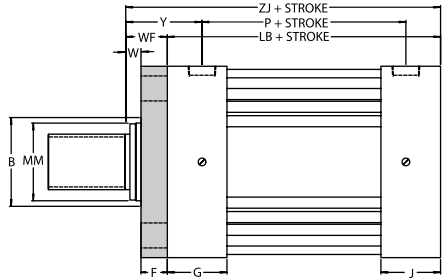
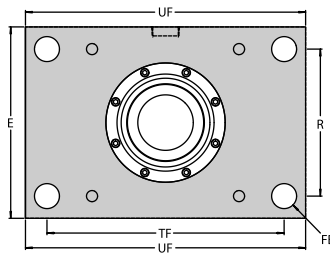

**STYLE BB—Square Flange
Mount Head End**
(NFPA Mounting Style MF5)

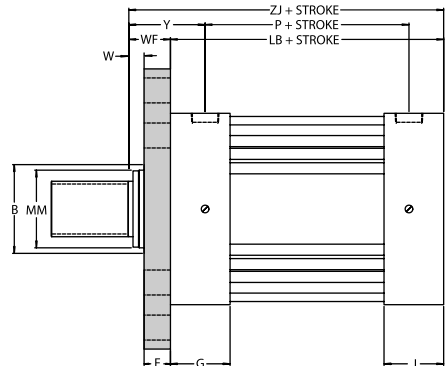
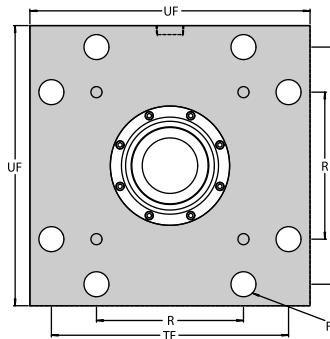

Styles A, B, AA and BB are not recommended for maximum operating pressures. Styles A and B can be used for 1000 psi maximum; styles AA and BB should be limited to 2500 psi maximum operating pressure. We recommend the use of high tensile mounting bolts on all flange mounted cylinders subjected to maximum pressures and shock loads.

ENVELOPE AND MOUNTING DIMENSIONS

BORE	E	EE	F	FB*	G	J	R	TF	UF	ADD STROKE	
										LB	P
10	12 ⁵ / ₈	2	1 ¹¹ / ₁₆	1 ³ / ₄	3 ¹¹ / ₁₆	3 ¹¹ / ₁₆	9.62	15 ⁷ / ₈	19	12 ¹ / ₈	8 ¹ / ₂
12	14 ⁷ / ₈	2 ¹ / ₂	1 ¹⁵ / ₁₆	2	4 ⁷ / ₁₆	4 ⁷ / ₁₆	11.45	18 ¹ / ₂	22	14 ¹ / ₂	10 ¹ / ₈
14	17 ¹ / ₄	2 ¹ / ₂	2 ³ / ₈	2 ¹ / ₄	5 ³ / ₈	5 ³ / ₈	13.25	21 ³ / ₈	25 ¹ / ₄	16 ⁵ / ₈	10 ³ / ₈

NPTF ports furnished as standard unless otherwise specified.

*Mounting holes are 1/16" larger than screw size shown.

ROD END DIMENSIONS

ENVELOPE AND MOUNTING DIMENSIONS

BORE	ROD DIA. MM	THREAD SIZE		ROD EXTENSIONS AND PILOT DIMENSIONS							ADD STROKE				
		KK	FF	A	+000 -002 B	C	D	NA	RD	V	WF	Y	W	ZJ	ZF
10	4 ¹ / ₂	3 ¹ / ₄ -12	4 ¹ / ₄ -12	4 ¹ / ₂	5.249	1	3 ⁷ / ₈	4 ³ / ₈	8	1 ¹ / ₄	2 ¹⁵ / ₁₆	4 ³ / ₄	1 ¹ / ₄	15 ¹ / ₁₆	16 ³ / ₄
	7	5-12	6 ³ / ₄ -12	7	7.999	1	—	6 ⁷ / ₈	10 ³ / ₄	1 ¹ / ₂	3 ³ / ₁₆	5	1 ¹ / ₂	15 ⁵ / ₁₆	17
	5	3 ¹ / ₂ -12	4 ³ / ₄ -12	5	5.749	1	4 ¹ / ₄	4 ⁷ / ₈	8 ¹ / ₂	1 ¹ / ₄	2 ¹⁵ / ₁₆	4 ³ / ₄	1 ¹ / ₄	15 ¹ / ₁₆	16 ³ / ₄
	5 ¹ / ₂	4-12	5 ¹ / ₄ -12	5 ¹ / ₂	6.249	1	4 ⁵ / ₈	5 ³ / ₈	9	1 ¹ / ₄	3 ³ / ₁₆	5	1 ¹ / ₂	15 ⁵ / ₁₆	17
12	5 ¹ / ₂	4-12	5 ¹ / ₄ -12	5 ¹ / ₂	6.249	1	4 ⁵ / ₈	5 ³ / ₈	9	1 ¹ / ₄	3 ³ / ₁₆	5 ³ / ₈	1 ¹ / ₄	17 ¹¹ / ₁₆	19 ⁵ / ₈
	8 ¹ / ₂	6-12	8 ¹ / ₄ -12	8 ¹ / ₂	9.499	1	—	8 ³ / ₈	12 ³ / ₄	1 ¹ / ₂	3 ³ / ₁₆	5 ⁵ / ₈	1 ¹ / ₂	17 ¹⁵ / ₁₆	19 ⁷ / ₈
	7	5-12	6 ³ / ₄ -12	7	7.999	1	—	6 ⁷ / ₈	10 ³ / ₄	3 ³ / ₈	3 ³ / ₁₆	5 ¹ / ₂	1 ³ / ₈	17 ¹³ / ₁₆	19 ³ / ₄
14	7	5-12	6 ³ / ₄ -12	7	7.999	1	—	6 ⁷ / ₈	10 ³ / ₄	3 ³ / ₈	3 ³ / ₄	6 ⁷ / ₈	1 ³ / ₈	20 ³ / ₈	22 ³ / ₄
	10	7-12	9 ³ / ₄ -12	10	10.999	1	—	9 ⁷ / ₈	14 ¹ / ₄	1 ¹ / ₂	3 ⁷ / ₈	7	1 ¹ / ₂	20 ¹ / ₂	22 ⁷ / ₈
	8 ¹ / ₂	6-12	8 ¹ / ₄ -12	8 ¹ / ₂	9.499	1	—	8 ³ / ₈	12 ³ / ₄	1 ¹ / ₂	3 ⁷ / ₈	7	1 ¹ / ₂	20 ¹ / ₂	22 ⁷ / ₈

Series 3TH

Heavy Duty Flange Mounted Cylinders

10.00" to 14.00"

STYLE P—Rectangular Cap End Mount
(NFPA Mounting Style ME6)

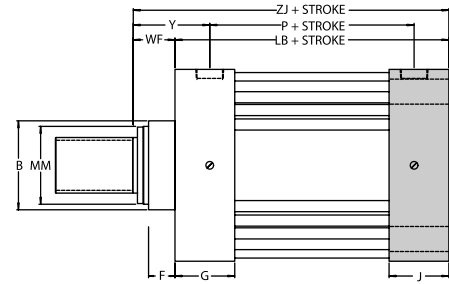
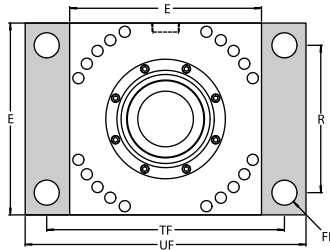

STYLE PP—Square Cap End Mount
(NFPA Mounting Style ME4)

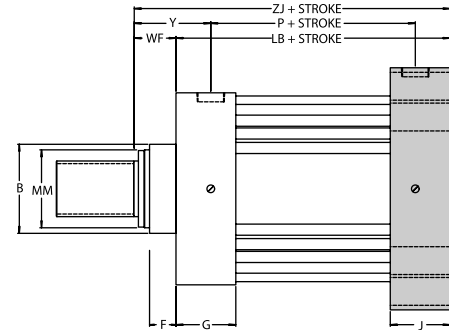
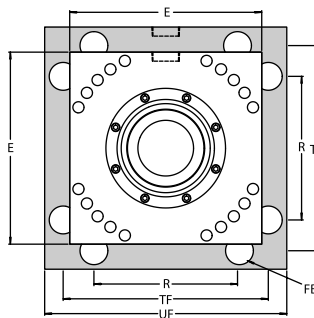

STYLE Q—Rectangular Head End Mount
(NFPA Mounting Style ME5)

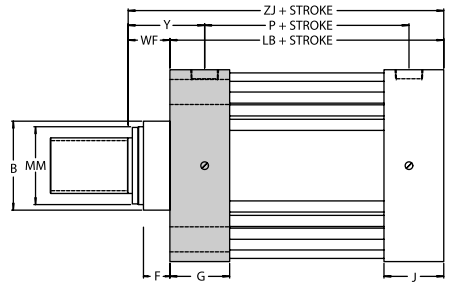
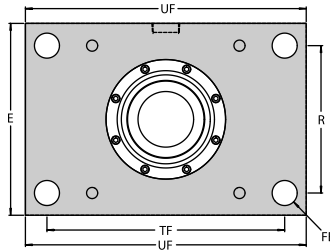

STYLE QQ—Square Head End Mount
(NFPA Mounting Style ME3)

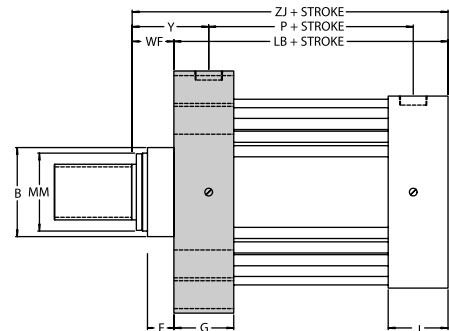
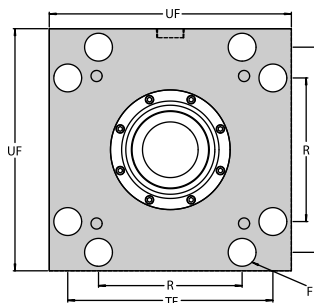

Series 3TH
Section 3

ENVELOPE AND MOUNTING DIMENSIONS

BORE	E	EB*	EE	EX	F	FB*	G	J	R	RE	TE	TF	UF	ADD STROKE	
														LB	P
10	12 ⁵ / ₈	1 ¹ / ₄	2	16 ⁵ / ₈	1 ¹¹ / ₁₆	1 ³ / ₄	3 ¹¹ / ₁₆	3 ¹¹ / ₁₆	9.62	9.89	14.13	15 ⁷ / ₈	19	12 ¹ / ₈	8 ¹ / ₂
12	14 ⁷ / ₈	1 ¹ / ₂	2 ¹ / ₂	19 ³ / ₄	1 ¹⁵ / ₁₆	2	4 ⁷ / ₁₆	4 ⁷ / ₁₆	11.45	11.75	16.79	18 ¹ / ₂	22	14 ¹ / ₂	10 ¹ / ₈
14	17 ¹ / ₄	1 ³ / ₄	2 ¹ / ₂	21 ³ / ₄	2 ³ / ₈	2 ¹ / ₄	5 ³ / ₈	5 ³ / ₈	13.25	12.90	18.43	21 ³ / ₈	25 ¹ / ₄	16 ⁵ / ₈	10 ³ / ₈

NPTF ports furnished as std. unless otherwise specified.

*Mounting holes are 1/16" larger than screw size shown.

ROD END DIMENSIONS

ENVELOPE AND MOUNTING DIMENSIONS

BORE	ROD DIA. MM	THREAD SIZE		ROD EXTENSIONS AND PILOT DIMENSIONS							WF	Y	W	ADD STROKE ZJ
		KK	FF	A	+000 -002 B	C	D	NA	RD	V				
10	4 ¹ / ₂	3 ¹ / ₄ -12	4 ¹ / ₄ -12	4 ¹ / ₂	5.249	1	3 ⁷ / ₈	4 ³ / ₈	8	1/4	2 ¹⁵ / ₁₆	4 ³ / ₄	1 ¹ / ₄	15 ¹ / ₁₆
	7	5-12	6 ³ / ₄ -12	7	7.999	1	—	6 ⁷ / ₈	10 ³ / ₄	1/2	3 ³ / ₁₆	5	1 ¹ / ₂	15 ⁵ / ₁₆
	5	3 ¹ / ₂ -12	4 ³ / ₄ -12	5	5.749	1	4 ¹ / ₄	4 ⁷ / ₈	8 ¹ / ₂	1/4	2 ¹⁵ / ₁₆	4 ³ / ₄	1 ¹ / ₄	15 ¹ / ₁₆
	5 ¹ / ₂	4-12	5 ¹ / ₄ -12	5 ¹ / ₂	6.249	1	4 ⁵ / ₈	5 ³ / ₈	9	1/2	3 ³ / ₁₆	5	1 ¹ / ₂	15 ⁵ / ₁₆
12	5 ¹ / ₂	4-12	5 ¹ / ₄ -12	5 ¹ / ₂	6.249	1	4 ⁵ / ₈	5 ³ / ₈	9	1/4	3 ³ / ₁₆	5 ³ / ₈	1 ¹ / ₄	17 ¹¹ / ₁₆
	8 ¹ / ₂	6-12	8 ¹ / ₄ -12	8 ¹ / ₂	9.499	1	—	8 ³ / ₈	12 ³ / ₄	1/2	3 ⁷ / ₁₆	5 ⁵ / ₈	1 ¹ / ₂	17 ¹⁵ / ₁₆
	7	5-12	6 ³ / ₄ -12	7	7.999	1	—	6 ⁷ / ₈	10 ³ / ₄	3/8	3 ⁵ / ₁₆	5 ¹ / ₂	1 ³ / ₈	17 ¹³ / ₁₆
14	7	5-12	6 ³ / ₄ -12	7	7.999	1	—	6 ⁷ / ₈	10 ³ / ₄	3/8	3 ³ / ₄	6 ⁷ / ₈	1 ³ / ₈	20 ³ / ₈
	10	7-12	9 ³ / ₄ -12	10	10.999	1	—	9 ⁷ / ₈	14 ¹ / ₄	1/2	3 ⁷ / ₈	7	1 ¹ / ₂	20 ¹ / ₂
	8 ¹ / ₂	6-12	8 ¹ / ₄ -12	8 ¹ / ₂	9.499	1	—	8 ³ / ₈	12 ³ / ₄	1/2	3 ⁷ / ₈	7	1 ¹ / ₂	20 ¹ / ₂

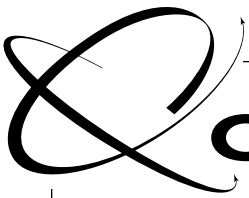

Quincy
PORTMAN CYLINDERS

Series 3TH

Large Bore Cylinder Mounts

16.00" to 20.00"

STYLE K—Center Line Mount
(NFPA Mounting Style MS3)

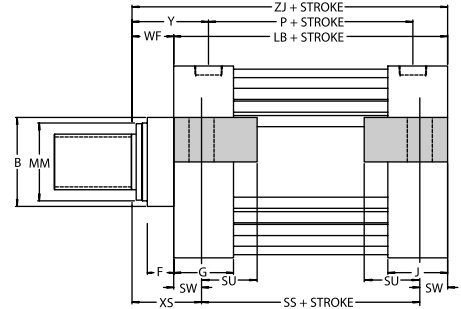
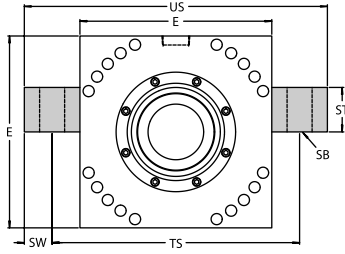

STYLE PP—Square Cap End Mount
(NFPA Mounting Style ME4)

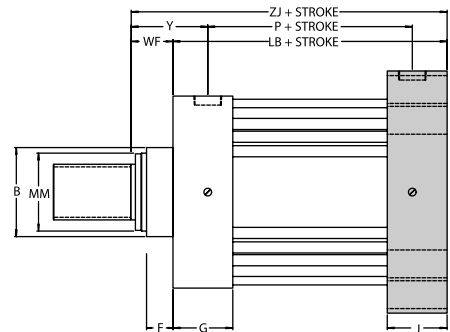
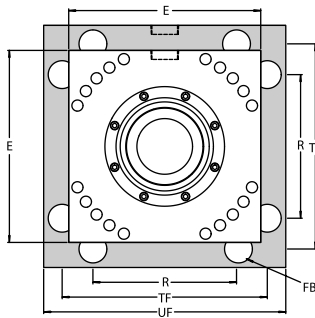

STYLE QQ—Square Heavy Duty Flange Mount Head End
(NFPA Mounting Style ME3)

Use Socket Head Cap Screws for Mounting Styles "QQ" and "PP" because of Tie Rod interference with Hex Bolt Heads. Mounting Holes are 1/16" larger than screw size shown.

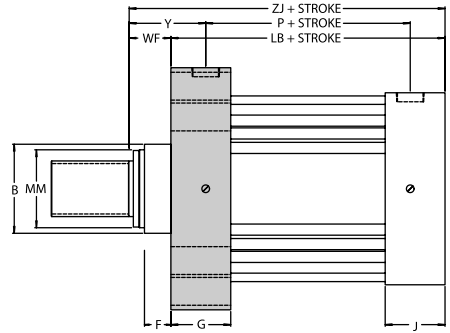
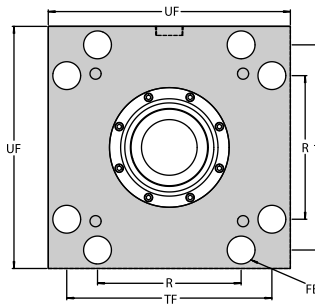

ENVELOPE AND MOUNTING DIMENSIONS

BORE	E	EB	EE	EX	F	G	J	K	RE	SB	ST	SU	SW	TE	TS	US	ADD STROKE		
																	LB	P	SS
16	19 1/4	1 3/4	3	24 1/2	2 3/8	5 7/8	5 7/8	1 1/2	15.28	2 1/2	4 1/2	5 1/4	2 3/4	21.03	24 1/4	29 1/4	18 1/8	11 7/8	12 5/8
18	22	2	3	26 1/2	2 3/8	6 3/8	6 3/8	1 1/8	16.45	2 3/4	5 1/4	5 1/2	3 1/4	22.65	27 1/2	33	20 1/8	12 7/8	13 5/8
20	24 3/4	2	3	29	2 3/8	7 3/8	7 3/8	1 1/8	15.19	3	6 1/2	6 3/8	3 7/8	25.62	31 1/4	37 3/4	23 1/8	13 3/8	15 3/8

ROD END DIMENSIONS

BORE	ROD DIA. MM	THREAD SIZE		ROD EXTENSIONS AND PILOT DIMENSIONS						WF	Y	W	XS	ADD STROKE	
		KK	FF	A	+000 -002 B	C	NA	RD	V					ZB	ZJ
16	8 1/2	6-12	8 1/4-12	8 1/2	9.499	1	8 3/8	12 3/4	1 1/2	3 7/8	7	1 1/2	6 5/8	23 1/2	22
	10	7-12	9 3/4-12	10	10.999	1	9 7/8	14 1/4	1 1/2	3 7/8	7	1 1/2	6 5/8	23 1/2	22
18	10	7-12	9 3/4-12	10	10.999	1	9 7/8	14 1/4	1 1/2	3 7/8	7 1/2	1 1/2	7 1/8	25 1/8	24
20	10	7-12	9 3/4-12	10	10.999	1	9 7/8	14 1/4	1 1/2	3 7/8	8 1/2	1 1/2	7 3/4	28 1/8	27

ENVELOPE AND MOUNTING DIMENSIONS

Series 3TH
Section 3

Series 3TH

Large Bore Cylinder Mounts

16.00" to 20.00"

STYLE ER—Trunnion Mount Head End
(NFPA Mounting Style MT1)

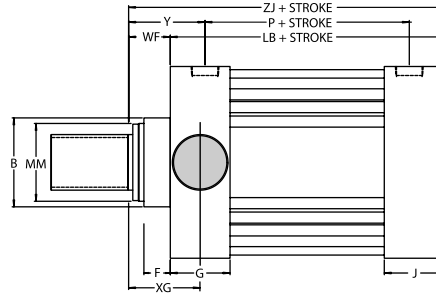
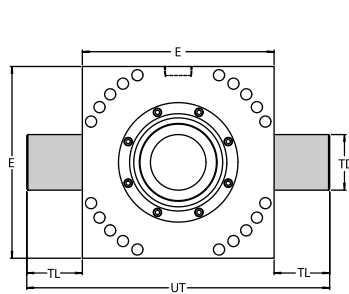

STYLE EB—Trunnion Mount Cap End
(NFPA Mounting Style MT2)

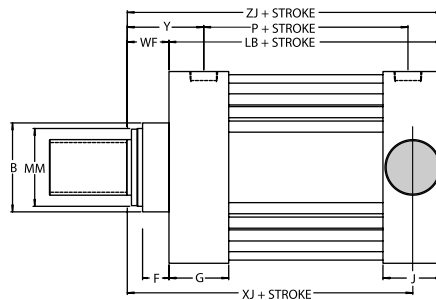
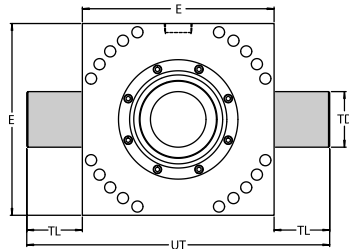

NOTES FOR STYLES "EB" AND "ER"

1. The trunnion pintles are not removable.
2. The trunnion pintles are designed to withstand shear loads but not high bending loads. Pillow blocks must be rigidly mounted to provide full support with minimum clearances.
3. Maximum operating pressure for cylinders with these mounts is 3000 psi non-shock.

STYLE G—Clevis Mount
(NFPA Mounting Style MP1)

Chrome-plated Clevis Pin Assembly (with Snap Rings) is furnished with all Style G Cylinders.

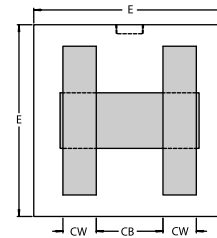
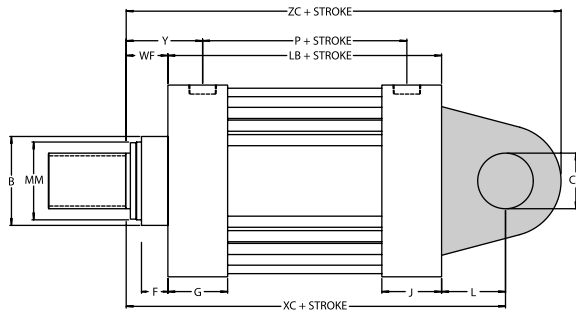

ENVELOPE AND MOUNTING DIMENSIONS

BORE	CB	±001 CD	CW	E	EE	F	G	J	K	L	LR	MR	+000 -001 TD	TL	UT	LB	P
16	7	6	3 1/2	19 1/4	3	2 3/8	5 7/8	5 7/8	1 1/2	7	6 1/8	6	5	5	29 1/4	18 1/8	11 7/8
18	8	6 1/2	4	22	3	2 3/8	6 3/8	6 3/8	1 1/8	7 3/8	6 5/8	6 1/2	5 3/4	5 3/4	33 1/2	20 1/8	12 7/8
20	9	7 1/2	4 1/2	24 3/4	3	2 3/8	7 3/8	7 3/8	1 1/8	8 3/4	7 5/8	7 1/2	6 1/4	6 1/4	37 1/4	23 1/8	13 3/8

ENVELOPE AND MOUNTING DIMENSIONS

ROD END DIMENSIONS

BORE	ROD DIA. MM	THREAD SIZE		ROD EXTENSIONS AND PILOT DIMENSIONS						ADD STROKE						
		KK	FF	A	+000 -002 B	C	NA	RD	V	WF	Y	XG	XC	XJ	ZB	ZC
16	8 1/2	6-12	8 1/4-12	8 1/2	9.499	1	8 3/8	12 3/4	1/2	3 7/8	7	6 13/16	29	19 1/16	23 1/2	35
	10	7-12	9 3/4-12	10	10.999	1	9 7/8	14 1/4	1/2	3 7/8	7	6 13/16	29	19 1/16	23 1/2	35
18	10	7-12	9 3/4-12	10	10.999	1	9 7/8	14 1/4	1/2	3 7/8	7 1/2	7 1/16	31 5/8	20 13/16	25 1/8	38 1/8
20	10	7-12	9 3/4-12	10	10.999	1	9 7/8	14 1/4	1/2	3 7/8	8 1/2	7 9/16	35 3/4	23 5/16	28 1/8	43 1/4

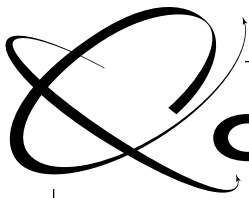

Quincy
ORTMAN CYLINDERS

Series 3TH

Heavy Duty Hydraulic Cylinders

Features

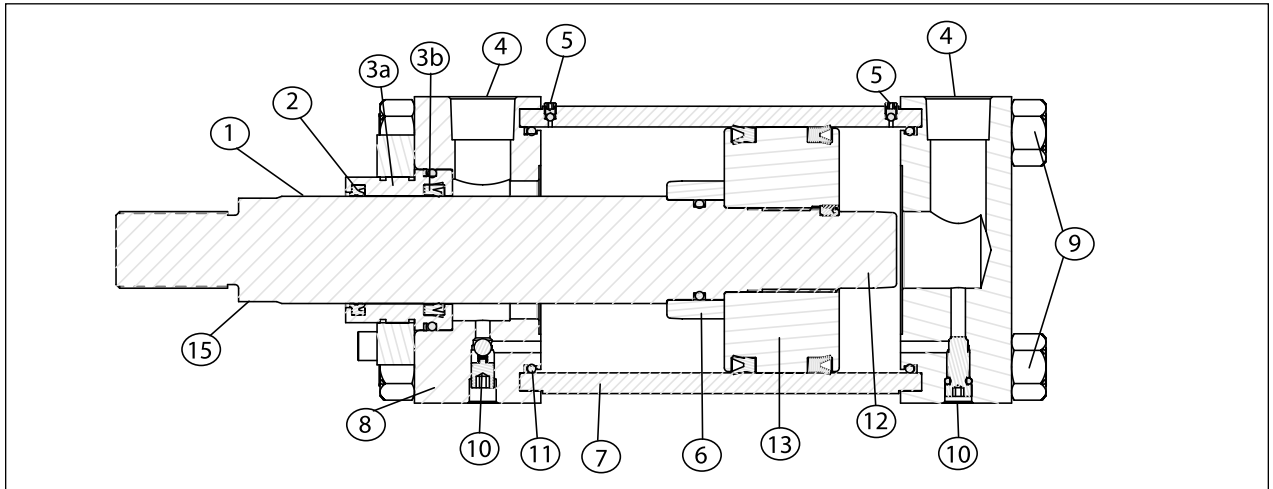

Series 3TH Section 3

1. Piston Rods— $\frac{5}{8}$ " thru 4" diameter are medium carbon steel with 100,000 psi minimum yield. Piston rods over 4" diameter have yield strengths between 50,000 and 90,000 psi. Sizes $\frac{5}{8}$ " thru 3 $\frac{1}{2}$ " diameter are induction case hardened to 54 Rockwell C. All piston rods are hard-chrome plated and highly polished.

2. Rod Wiper—Polyurethane, double lip type wiper designed to protect the piston rod, bearing and rod seal, is standard for all rod sizes. Also, metallic scrapers and Viton wipers are available for all rod sizes.

3. Bolted Rod Gland Cartridges—Heavy wall, ductile iron bearing is accurately piloted in head to assure perfect alignment, designed to accept a variety of seal styles. With certain exceptions, the cartridges can be removed without removing mounts or tie rod nuts. This eliminates the necessity of cylinder disassembly to replace the rod seals or rod bearing. Bearings are held in place with bolted steel retainer plates.

Bearing used for a given rod size are interchangeable into any cylinder bore with the same rod diameter.

a. Rod Seal—Polyurethane compound, flexible lip type rod seal has excellent abrasion resistance and is wear compensating. Inherent characteristics of the material and design assure leak-proof performance and long life.

b. Rod Bearing—Ductile iron material insures low friction, high load capabilities and long life.

4. Ports—Large unrestricted ports permit maximum flow with minimum pressure drop. Heads may be rotated independently at 90° intervals for convenient port location. SAE straight thread ports are optional. Oversize ports, one size larger than standard, can be furnished on most bore sizes by welding a half-coupling to the standard head or cap.

5. Air Bleeds—Ball and setscrews are provided in the barrel when specified. The barrel can be rotated to place bleeders at top regardless of mounting position.

6. Head End Cushion—Floating type head end cushions are retained by shoulder on the rod.

7. Cylinder Barrel—The barrel is constructed of carefully selected, heavy wall steel tubing. The tubing is microhoned to assure smooth operation with minimum friction.

8. Heads—Rolled-steel heads are accurately machined to assure perfect alignment of piston rod and cylinder bore. Heads pilot on bore of tube and confine O.D. to prevent breathing. This provides additional insurance against leakage.

9. Tie Rods and Nuts—Tie rods are made from 100,000 psi minimum yield, medium carbon steel. They are pre-stressed at assembly with hi-strength alloy hex nuts.

10. Needle valves and check valves—Flush type needle valves and check valves are supplied. Large drilled passages provide maximum control of cushioning effect and assure rapid full power starts at beginning of stroke. Needle valves begin to leak prior to disengagement to prevent valve blow out. Ball checks are permanently retained.

11. Tube Seal—O-ring with back up washer assures a positive seal between head and barrel.

12. Cap End Cushion Plunger—Accurately machined cap end is an integral part of the piston rod.

13. Polyurethane U-Cup Type Piston—This type piston with polyurethane seals is standard in 3TH series cylinders and will be furnished unless otherwise specified. The piston, one-piece high grade alloy iron is pilot fitted to the piston rod and locked. Polyurethane flexible lip type

piston seals have excellent abrasion resistance and wear compensating. Inherent characteristics of the material and design assure leak-proof performance and long life.

14. Ring Type Piston—This type piston, one piece high grade alloy iron is pilot fitted to the piston rod and locked. Ring type piston provides long life with trouble-free service. Application, however, must tolerate a moderate amount of by-pass.

NOTE: All types of pistons use the same rods and are interchangeable.

15. Wrench Flats—Large wrench flats are chamfered to protect rod gland packing in installation. Standard piston rods thru 5 $\frac{1}{2}$ " diameter are furnished with two wrench flats, and additional flats are available upon request. Spanner holes are furnished in place of flats on 7" thru 10" diameter rods.

Mounts—All mounts are of steel plate or fabricated steel, accurately machined for precise mounting.

JIC—These cylinders are designed to conform to JIC standards.

NFPA—The dimensioning and identification of the cylinders in this catalog are in accordance with the NFPA recommended dimension code for fluid power cylinders.

Endurance Pressure Rating—The pressure containing envelope of cylinders (tube, tie rods, end covers) are fatigue pressure rated at 3000 psi. For endurance pressure rating of mounts and other cylinder components consult the sales department.

For additional information contact your nearest distributor or the factory sales department.

NOTE: If cylinders are to be stored for prolonged periods, contact Quincy/Ortman for instructions.