



EAT•N Hydro-Line

Industrial Tie Rod Cylinders

NFFPA Interchangeable

Technical Manual

N5

AN5

LAN5



Table of Contents

| | |
|---|----|
| N5 Design Features | 3 |
| How to Order..... | 5 |
| N5 Standard Design Options..... | 6 |
| N5 Cylinder Types | 7 |
| Application Data Sheet | 9 |
| N5 Mounting Application Data..... | 10 |
| N5 Mounting Dimensions | 11 |
| Tie Rod Information | 20 |
| Technical Data..... | 20 |
| Port Data..... | 26 |
| N5 Series Hydraulic Pressure Ratings..... | 27 |
| Typical Mounting Accessories | 28 |
| Cylinder Mounting Accessories | 29 |
| Mounting Accessories | 31 |
| Self Aligning Coupler | 32 |
| Rod End Coupling | 33 |
| Custom Cylinders | 34 |
| Rod End Styles | 35 |
| Oversized Rods..... | 36 |

N5 Design Features

A Heavy Duty Rod Cartridge

- Machined from gray iron for maximum bearing support and wear resistance
- Unitized, threadless assembly is pilot-fitted into the head on a precision bored diameter to assure true concentricity (See Fig. 3-1)

B Piston Seals

- Step cut iron piston rings standard on N5
- Nitrile lip-type seals standard on AN5 and LAN5
- Viton lip seals available for special fluid compatibility or temperatures to 400°F
- Special seals for high speed, low friction and other requirements are available

Key Features

Unitized Rod Cartridge Construction

- The unitized construction contains all cartridge seals in one assembly
- Standard removable retainer allows cartridge removal with hex wrench without loosening the tie rods
- See Page 5 for exceptions

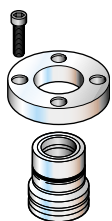

Figure 3-1

C Long Life Urethane Rod Seals

- Urethane "Ultra-Seal" standard through 8" rod diameters on N5 cylinders providing the optimum in long life and sealing up to 200°F (see Fig. 3-3)
- Viton PolyPak seals available on N5 for special fluids or temperatures to 400°F

- Nitrile lip-type seals standard on AN5 and LAN5
- Special seals available

D Double-lipped Rod Wiper

- Carboxylated double-lipped rod wiper removes foreign materials from the exposed rod to extend rod seal life
- The standard rod wiper is carboxylated material through 5 1/2"; Viton for 7" through 10" diameter rods
- Metallic rod scraper and low friction wipers available

Sculptured Floating Cushions

Self-centering cushions are sculptured to allow the cylinder driving force and load to be absorbed gradually and smoothly over the entire cushion length maintaining near constant pressure. Refer to pages 20 and 21 to determine your specific cushion requirements.

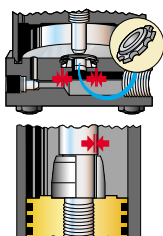

Figure 3-2

E SAE Ports

- SAE ports standard on N5; NPTF ports available at no extra charge
- NPTF ports standard on AN5 and LAN5; SAE ports available at no extra charge
- Metric, BSP, Manifold, Flange and other porting options available

F Teflon Tube Seals

- Superior design to prevent leakage
- Compatible with virtually all fluids
- Operating temperatures to 500°F

G Floating Cap Cushion Insert

- Floating design allows closer tolerance, yet minimum wear (see Fig. 3-2)
- Replaces ball check to provide greater flow area for fast breakaway

H Captive Cushion Adjustment

- Inner hex allows safe cushion adjustment under pressure
- Fine threads and special tip design allows for precise adjustment over a broad range of operating conditions

I Precision Steel Heads and Caps

- Provides truly flat and parallel mounting surfaces
- Insures correct alignment of tube and rod cartridge

J Self Centering Head Cushion

- Floating design allows closer tolerances, yet minimum wear (see Fig. 3-2)
- Sculptured shape provides constant deceleration curve
- Large size ball check provided at head end for fast breakaway

K Damage Resistant Piston Rod

- 5/8" through 4 1/2" diameters use 90,000 to 100,000 minimum psi yield steel, case hardened and hard chrome plated
- Over 5" diameter uses 41,000 to 80,000 psi yield steel, hard chrome plated
- All rods polished to 8-14 micro inch finish for long seal life
- 17-4 PH stainless steel and other materials also available

L Studded Piston Rod End

- Roll-threaded 125,000 minimum psi yield steel
- Greater strength and fatigue resistance
- Standard on 5/8", 1" and 1 3/8" diameter rods in styles 1, 1X, 2 and 2X
- Available on 1 3/4", 2" and 2 1/2" rods in styles 1, 1X, 2 and 2X upon request

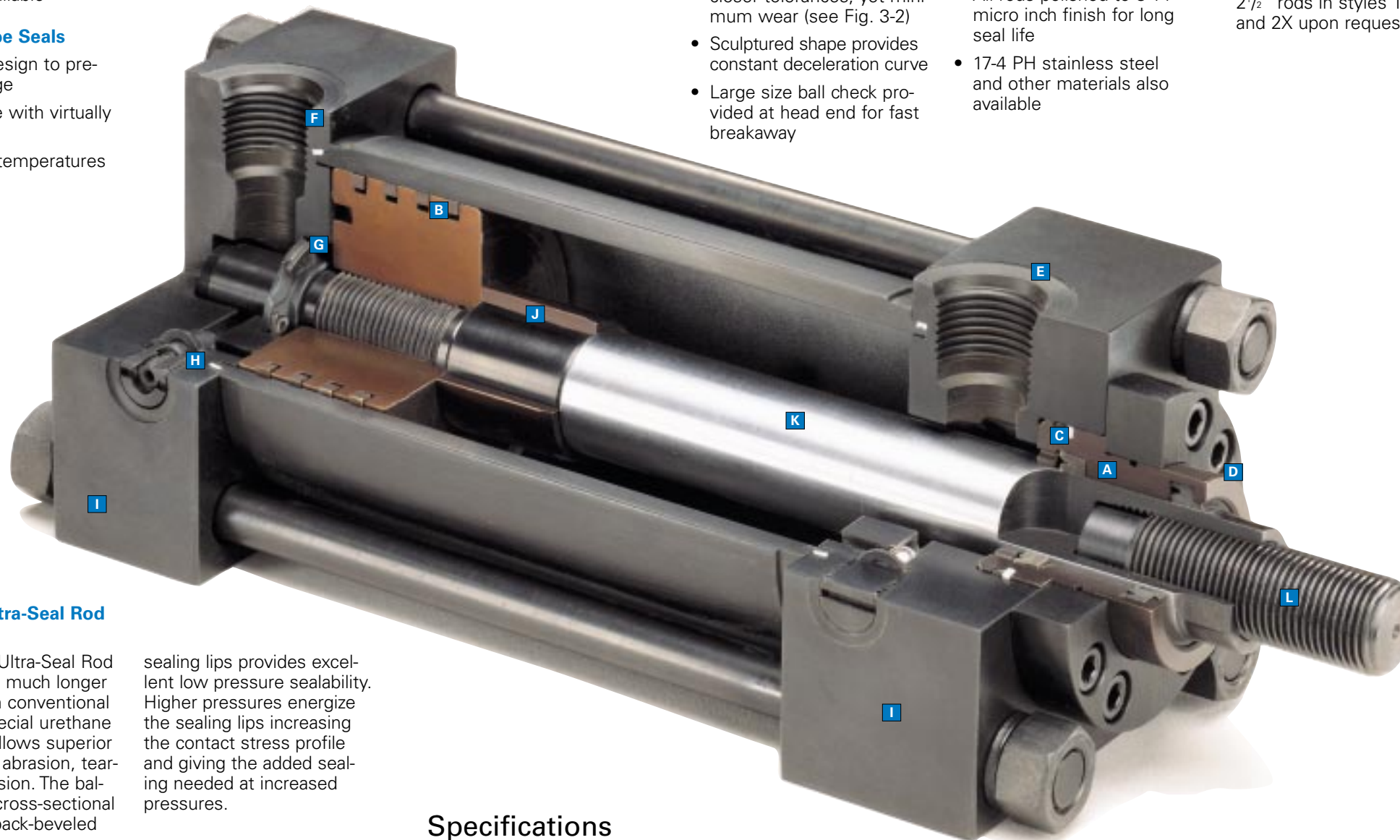

Hydro-Line's Ultra-Seal Rod Seal provides much longer wear life than conventional rod seals. Special urethane formulation allows superior resistance to abrasion, tearing and extrusion. The balanced radial cross-sectional design with back-beveled sealing lips provides excellent low pressure sealability. Higher pressures energize the sealing lips increasing the contact stress profile and giving the added sealing needed at increased pressures.

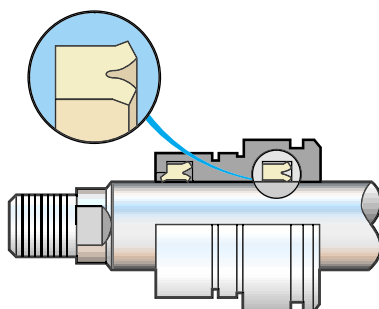

Figure 3-3

Specifications

Bore Sizes

1 1/2" through 30"

Pressure Ratings

N5 – 3000 psi hydraulic – nominal AN5, LAN5 – 250 psi air. See page 23 for specific pressure ratings and safety factors.

Temperature

-40°F to 200°F standard

NFPA interchangeable mountings

N5

Hydraulic cylinders incorporate urethane Ultra-Seal rod seals, carboxylated double-lipped rod wipers, cast iron piston rings, honed steel tubing I.D. and SAE ports.

AN5

Pneumatic cylinders incorporate carboxylated lip-type rod seals, carboxylated double-lipped rod wipers, carboxylated piston seals, .0003/.0005" thick chrome plated tube I.D. and NPTF ports.

LAN5

Pneumatic cylinders incorporate all AN5 features and are also permanently lubricated at assembly by filling the piston and rod seals "V" groove with molybdenum disulfide grease.

How to Order an N5 Cylinder

Eaton Hydro-Line standard cylinders can be completely and accurately identified with a model number that encodes construction specifications. To develop the model number for ordering a cylinder, see the following example:

How to Order

1. Quantity
2. Model number
3. Special modifications if required
4. Completed Application Data Sheet(s) (page 8) if required.
5. Required ship date

EATON | Hydro-Line

N5KD-3.25 X 8.00-N-1.38-2-T-H-R-1-1-X

194011234-1
A11579-375

Customer Number (if desired)
Plant & Date Code

Sample Model Code

N5 KD - 3.25 X 8.00 - N - 1.38 - 2 - T - H - R - 1 - 1 - X

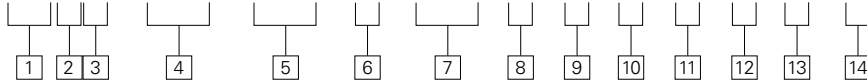

| FEATURE | DESCRIPTION | SYMBOL |
|------------------|--|--|
| 1 Model Series | Hydraulic high pressure Air heavy duty Air heavy duty prelubricated | N5 AN5 LAN5 |
| 2 Mounting Style | Side lugs, MS2 Side tapped, MS4 Cap fixed clevis, MP1 Cap spherical bearing Cap detachable clevis, MP2 Side end lugs, MS7 Head rectangular flange, MF1 Head rectangular, ME5 Center-line lugs, MS3 Head square flange, MF5 No mount All tie rods extended, MX1 Head end tie rods extended, MX3 Cap end tie rods extended, MX2 Cap rectangular, ME6 Cap rectangular flange, MF2 Cap square flange, MF6 Intermediate fixed trunnion, MT4 Head trunnion, MT1 Cap trunnion, MT2 | A B C CS DC E F G H J K L M N P R S TT U W |
| 3 Double Rod | Include ONLY for double-rod cylinder | D |
| 4 Bore | Specify in inches (2 position decimal) | - |
| 5 Stroke | Specify in inches (2 position decimal) | - |
| 6 Cushions | Noncushioned Cushioned both ends Cushioned head end Cushioned cap end | N B H C |
| 7 Rod Diameter | Specify in inches (2 position decimal) | - |
| 8 Rod End Style | Male, large Male, large, extended Male, small (standard) Male, small, extended Male modified Female Female modified Plain end Male, full rod diameter Male, for rod end coupling Modified | 1 1X 2 2X 2M 4 4M 5 6 10 M |

| FEATURE | DESCRIPTION | SYMBOL |
|--------------------------|--|--|
| 9 Ports | NPTF †SAE *SAE #12, standard for 31/4", 4" and 5" bore cylinders Manifold Flange BSP/G Special | N S T M F G X |
| 10 Rod Seals | Urethane Ultra-Seal Carboxylated lip type PolyPak ‡Viton PolyPak ‡Viton lip type Ultra-Seal with scraper Nitrile lip type with scraper ‡Viton PolyPak with scraper ‡Viton lip type with scraper Special | H N P F V J S G U X |
| 11 Piston Seals | Carboxylated lip type Low friction PolyPak PolyPak Cast iron rings ‡Viton lip type Low breakaway Teflon radial seal with wearband Special | N D P R V B X |
| 12 Port Locations | Head end positions Special | 1-4 X |
| 13 Port Locations | Cap end positions Special | 1-5 X |
| 14 Special Modifications | Include ONLY if special modifications are required. Air bleeders Drainbacks Special seals Nonstd. mount Oversize ports Bronze bushings Key Plate Stop tube | X Rod boots Indicator switches Four rod end flats Port or cushion modifications Double-end rod with different rod ends Special paint/plating Stainless steel rod |

* To order standard SAE #12 ports on 31/4", 4" and 5" bore, use T.

† To order oversize SAE #16 ports on 31/4", 4" and 5" bore, use S.

‡ Consider specifying pinning the piston to the piston rod for temperatures over 250° F.

Port Locations

Port location 5 is on the center of the back face of the end cap.

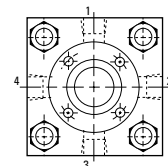

N5 Series Standard Design Options

Metallic Rod Scrapers

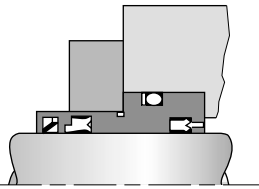

A Metallic Rod Scraper provides increased rod seal life by removing abrasive contamination from the rod in severe applications.

Air Bleeders

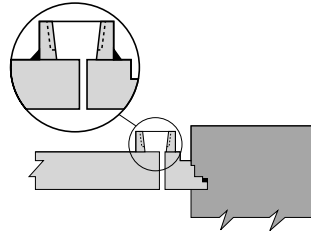

$\frac{1}{8}$ " NPTF bleeders are located in the tube or in the head and cap when specified. SAE #2 bleeders located in the head and cap are also available when specified. All bleeders may be located in positions 1, 2, 3 or 4.

Rod Boots

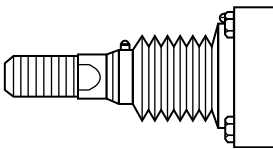

A rod boot surrounds the piston rod with an external, expandable cover to protect the rod surface from external contamination. Requires additional rod length which is determined by the cylinder stroke.

Wearbands

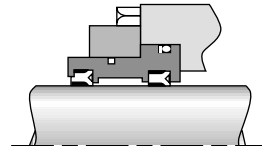

Wearbands fitted to the piston and/or rod cartridge eliminate metal-to-metal contact on the piston/tube I.D. and the cartridge/rod O.D. Bronze-filled Teflon wearband material reduces friction and wear in applications where side-load is present.

Low Breakaway Piston

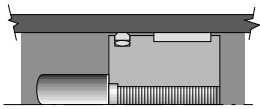

A low breakaway piston reduces running friction and metal-to-metal contact by utilizing a bronze-filled Teflon wearband and a bi-directional, O-ring energized, bronze-filled Teflon piston seal.

Special Rod Ends

Modifications of standard rod ends or completely special rod end styles are available to meet unique rod end connection requirements. (See page 35.)

Special Ports

Metric, BSP, Manifold and other porting options are available to meet specific requirements. (See page 26).

Extra Heavy Chrome Tubes and Rods

Added wear and corrosion resistance are available by specifying Extra Heavy Chrome (.002" to .003" thick).

Electronic Feedback

A complete line of precision cylinder position sensing and feedback devices are available. These packaged cylinder systems can handle virtually any application requiring feedback throughout the cylinder stroke — pneumatic or hydraulic, large or small bore, long or short strokes, with or without velocity monitoring — with resolutions of ± 0.001 " or better. (See the Hydro-Line Systems Catalog).

Stainless Steel Piston Rods

Piston rods in 300 and 400 series, 17-4 PH and others are available for those applications requiring increased corrosion resistance.

Special Coating and Painting

Cylinders can be prepared with a primer coat, epoxy, lacquer or enamel paint finish coatings to customer specifications. Synergistic, Nitrocarburizing and other material treatments are also available for special applications.

Plating

Electroless Nickel, Cadmium and other plating finishes are available for corrosive, wash-down, pharmaceutical and other applications.

Special Materials

Bronze rod cartridges, brass, aluminum and composite tubing, complete stainless steel cylinders or other special materials are available to meet most unique material requirements.

N5 Series Cylinder Types

Single/Double Acting Cylinders

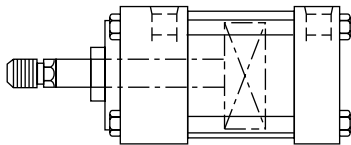

Standard N5 Series cylinders are double acting, with fluid power driving the piston in both directions. Single acting cylinders have fluid power driving the piston in one direction, relying on either the load or an external force to return the piston after the pressure is released.

Back-to-back Cylinders

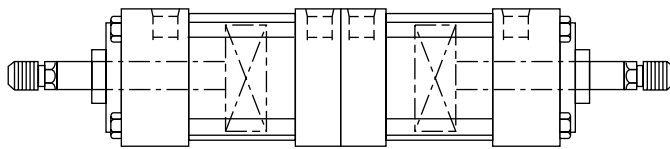

Back-to-back cylinders are two single rod cylinders mounted together at the caps. Combinations of positions are possible through various combinations of piston actuation. Consult Eaton for maximum operating pressure.

Multiple Position Cylinders

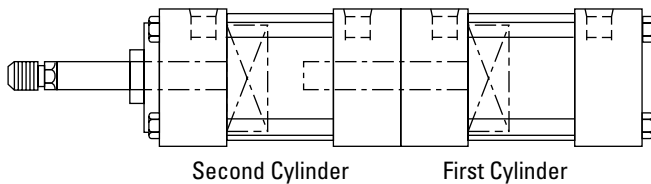

Multiple position cylinders are similar to tandem cylinders (except that the piston and rod assemblies are not connected) in that the output force is increased.

Additionally, they may act as a precision multiple positioning device by actuating each cylinder successively or independently. Consult Eaton for maximum operating pressure.

Tandem Cylinders

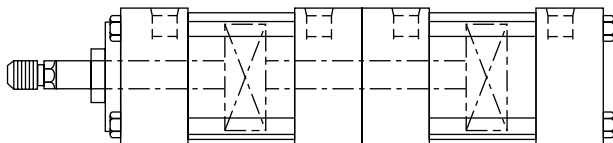

Tandem cylinders consist of two cylinders interconnected (piston and rod assemblies are connected). Pressure can act on two effective piston areas allowing the cylinder to be used as a force multiplier. This type of cylinder can also be used in air/oil systems to provide smooth, metered

flow because of equal volumes in one chamber of both cylinders. Consult Eaton for maximum operating pressure.

Note
Front cylinder stroke is $\frac{1}{8}$ " longer at front cylinder when strokes are the same.

Double End Cylinders Back-to-Back

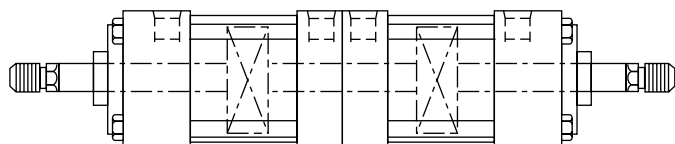

Double end cylinders mounted back-to-back have common piston rod and tie rods and the same stroke length. Consult Eaton for maximum operating pressure.

Note
Cylinder length is $\frac{1}{8}$ " longer on one cylinder.

N5 Series Cylinder Types

Spring Return/Extend Cylinders

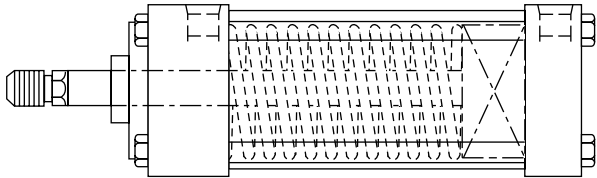

Spring return/extend cylinders provide thrust in one direction only (can be either direction). One port is used for pressure to act against the load while the inactive port is vented. An internal spring is used to return the cylinder to its normal position.

Electronic Feedback Cylinders

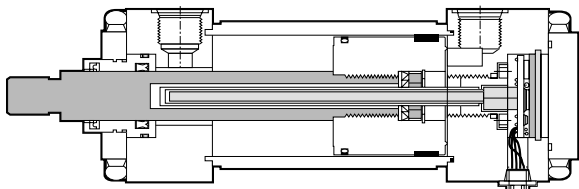

These cylinders integrate position sensing and control valves to produce a complete servoactuator package. Eaton's unique HLT In-Cylinder magnetostriuctive feedback sensor provides a compact, robust package. External magnetostriuctive (with protective covers) or

internally mounted linear potentiometer transducers provide additional options. Valve, manifold blocks and a variety of servocontrol valves may be added to yield a complete control solution.

Adjustable Stroke Cylinders

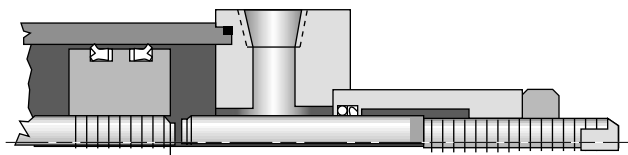

Adjustable stroke cylinders are furnished with a stroke adjusting screw in the cap end of the cylinder. Adjusting this screw in or out limits the retract stroke to the precise length desired.

Non-rotating Cylinders

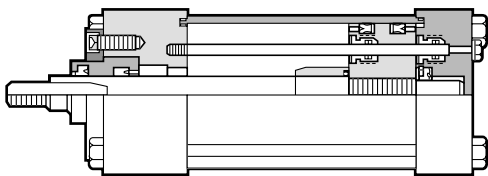

Non-rotating cylinders are furnished with internal guide rods which prevent piston rod rotation throughout the stroke. Rotational torque and stroke length determine the amount and diameter of the guide rods.

Pumping Units

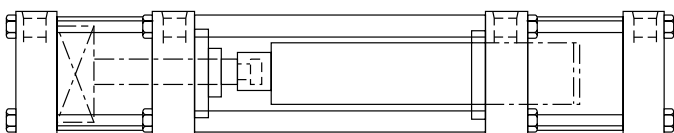

Pumping units consist of a standard hydraulic cylinder coupled with a volume displacing lance cylinder via tie-bars. Special seals and lance surface treatments are avail-

able to provide compatibility with resins and chemicals used in the pumping process. Single and double ended designs are available.

Eaton Application Data Sheet

| | |
|--|--|
| Company Name: _____ Contact: _____ Phone Number: _____ Fax Number: _____ | Distributor Name: _____ Contact: _____ Phone Number: _____ Fax Number: _____ |
|--|--|

| | | | | | | | | | | |
|--|-------------------------------|--------------------------|--------------------------|--------------------------|--------------------------|--------------------------|--------------------------|------------------------------|--------------------------|--------------------------|
| QUANTITY <input type="text"/> <input type="text"/> <input type="text"/> <input type="text"/> | Model Numbering System | | | | | | | | | |
| Model/Series | Mount | Bore | Stroke | Cushion | Rod Diameter | Rod End Style | Ports | Seals Rod Piston Head Cap | Port Location | Model |
| <input type="checkbox"/> | <input type="checkbox"/> | <input type="checkbox"/> | <input type="checkbox"/> | <input type="checkbox"/> | <input type="checkbox"/> | <input type="checkbox"/> | <input type="checkbox"/> | <input type="checkbox"/> | <input type="checkbox"/> | <input type="checkbox"/> |
| Double End Rod Style | Additional Rod Length | Needle Location | Keyplate | 4-Flat | Bleeders | Bronze Bushing | Drain-back | Ind. Switch | Model Prefix | |
| <input type="checkbox"/> | <input type="checkbox"/> | <input type="checkbox"/> | <input type="checkbox"/> | <input type="checkbox"/> | <input type="checkbox"/> | <input type="checkbox"/> | <input type="checkbox"/> | <input type="checkbox"/> | <input type="checkbox"/> | |
| Stop Tube Length | Trunnion XI Dimension | | Stainless Steel Rod Type | | | | | | | |
| <input type="checkbox"/> | <input type="checkbox"/> | | <input type="checkbox"/> | | | | | | | |

Please fill in all available information above. Refer to the Hydro-Line Model Numbering System on Pages 2.

| | | | | | | | | | | | | | | | | | | | | | | | | | |
|---|---------------------------|--------------------------------|--------------------------------|-----------|-------------------|------------------|-----------|-------------------|------------------|-------------|-------------------|------------------|------------------|--|--|---|-------------|------------------|--------------------------|-----------------|-----------------------|--|-----------------|------------------------|--------------------|
| WHAT IS THE OPERATING ENVIRONMENT? <table style="width:100%; font-size: x-small;"> <tr> <td>Fluid Media</td> <td>Operating Pressure</td> <td>Temperature at Cylinder</td> </tr> <tr> <td>Air _____</td> <td>Minimum _____ psi</td> <td>Minimum _____ °F</td> </tr> <tr> <td>Oil _____</td> <td>Typical _____ psi</td> <td>Typical _____ °F</td> </tr> <tr> <td>Other _____</td> <td>Maximum _____ psi</td> <td>Maximum _____ °F</td> </tr> <tr> <td>Fluid Type _____</td> <td colspan="2"></td> </tr> </table> | Fluid Media | Operating Pressure | Temperature at Cylinder | Air _____ | Minimum _____ psi | Minimum _____ °F | Oil _____ | Typical _____ psi | Typical _____ °F | Other _____ | Maximum _____ psi | Maximum _____ °F | Fluid Type _____ | | | WHAT IS THE WORK BEING PERFORMED? <table style="width:100%; font-size: x-small;"> <tr> <td>Load</td> <td>Rod Speed</td> <td>Cycles per Minute</td> </tr> <tr> <td>Push _____ lbs.</td> <td>Extend _____ in./sec.</td> <td></td> </tr> <tr> <td>Pull _____ lbs.</td> <td>Retract _____ in./sec.</td> <td>_____ (in and out)</td> </tr> </table> | Load | Rod Speed | Cycles per Minute | Push _____ lbs. | Extend _____ in./sec. | | Pull _____ lbs. | Retract _____ in./sec. | _____ (in and out) |
| Fluid Media | Operating Pressure | Temperature at Cylinder | | | | | | | | | | | | | | | | | | | | | | | |
| Air _____ | Minimum _____ psi | Minimum _____ °F | | | | | | | | | | | | | | | | | | | | | | | |
| Oil _____ | Typical _____ psi | Typical _____ °F | | | | | | | | | | | | | | | | | | | | | | | |
| Other _____ | Maximum _____ psi | Maximum _____ °F | | | | | | | | | | | | | | | | | | | | | | | |
| Fluid Type _____ | | | | | | | | | | | | | | | | | | | | | | | | | |
| Load | Rod Speed | Cycles per Minute | | | | | | | | | | | | | | | | | | | | | | | |
| Push _____ lbs. | Extend _____ in./sec. | | | | | | | | | | | | | | | | | | | | | | | | |
| Pull _____ lbs. | Retract _____ in./sec. | _____ (in and out) | | | | | | | | | | | | | | | | | | | | | | | |

| | | | |
|--------------------------|-----------------------------|---------------------------|------------------------|
| WHAT IS MOUNTING? | | | |
| Attitude | | Rod End Connection | Known Side Load |
| Vertical _____ | Angle _____ | Firmly Guided _____ | |
| | Degrees From Vertical _____ | Supported _____ | _____ lbs. |
| Rod Up _____ | Rod Up _____ | Unsupported _____ | |
| Rod Down _____ | Rod Down _____ | | |

| |
|--|
| WHAT ENVIRONMENTAL CONDITIONS IS THE CYLINDER SUBJECTED TO? |
| Standard Factory _____ Corrosive Washdown _____ Chemical? _____ Outdoors _____ Other _____ |

| |
|--|
| WHAT IS THE PRESENT CYLINDER TYPE AND MODEL NUMBER? |
| |

| |
|-------------------------------------|
| WHAT IS THE PRESENT PROBLEM? |
| |

| | | |
|---|--|---|
| WHAT INDUSTRY IS THE CYLINDER USED IN? | WHAT TYPE OF MACHINE IS THE CYLINDER USED ON? | WHAT IS THE CYLINDER NAME THE APPLICATION? |
| | | |

| | |
|----------------------------|---|
| APPLICATION SKETCH: | DESCRIPTION OF APPLICATION OR SPECIAL REQUIREMENT: |
| | |

| | | | |
|--------------------------|-----------------|--------------|--------------------------|
| PREPARED BY: | DATE: | REVIEWED BY: | DATE: |
| CUSTOMER DRAWING NUMBER: | REVISION DATES: | | HYDRO-LINE QUOTE NUMBER: |
| | | | |

N5 Series Mounting Application Data

Side- and Center-line Mountings

These mounts should be keyed or pinned to prevent shifting during operation. Keys or pins must be strong enough to resist the full thrust of the cylinder. The lugs on A and H mounts are large enough to accommodate dowel pins. Extended key plates for stock and custom cylinder models are available when specified. Pin or key the head whenever possible. Do not pin or key both ends. Cylinders become longer when pressure is applied and tube will tend to buckle.

The alignment and center-line height on the E mount are maintained by accurately machined surfaces on the head and cap which are held against the mounting surface by the end lugs.

End and Intermediate Pivot Mountings

Trunnion and pivot pins are designed to carry shear loads only. Trunnion and pivot bearings must fit closely for the entire length of the pin. Hold the trunnion bearings rigidly and in accurate alignment.

End Mountings

The head and cap rectangular mounts G and P should be used for hydraulic applications to avoid excessive deflection which occurs on the F and R mountings.

Refer to the chart on page 13 for pressure ratings for F mounts in push and R mounts in pull.

The G, P, J and S mounts are usable in both push and pull at full rated hydraulic pressures as shown on page 27.

Piston Securing Methods

Piston to rod joints are threaded, anaerobically sealed and secured, and staked (single rod ends). Under normal operating conditions, additional securing is not necessary. However, in applications where: 1) temperatures exceed 250°F, 2) pressure spike or impact shock is present, or 3) a piston previously detached, the piston should be pinned; this must be specified when ordering. Consult factory for other securing methods.

Double Rod Cylinders

Double rod cylinders are available in all mountings except C, CS, DC, N, P, R, S and W. Use the basic dimensional information on page 17 combined with dimensions in the drawings on pages 11-19.

Mounting Accessories

See pages 28-32 for mounting accessories.

| DESCRIPTION | MOUNT | NFPA DESIGNATION | N5 BORES AVAILABLE |
|------------------|-------|------------------|---------------------|
| Side Lugs | A | MS2 | 1 1/2" - 8" |
| Side Tapped | B | MS4 | 1 1/2" - 8" |
| Center-Line Lugs | H | ** | MS3 1 1/2" - 20" |
| Side End Lugs | E | MS7 | 1 1/2" - 8" |

| DESCRIPTION | MOUNT | NFPA DESIGNATION | N5 BORES AVAILABLE |
|-----------------------------|-------|------------------|--------------------|
| Cap Fixed Clevis | C | **MP1 | 1 1/2" - 30" |
| Cap Spherical Bearing | CS | N/A | 1 1/2" - 6" |
| Detachable Clevis | DC | MP2 | 1 1/2" - 8" |
| Head Trunnion | U | **MT1 | 1" - 30" |
| Cap Trunnion | W | **MT2 | 1 1/2" - 30" |
| Intermediate Fixed Trunnion | TT | **MT4 | 1 1/2" - 30" |

| DESCRIPTION | MOUNT | NFPA DESIGNATION | N5 BORES AVAILABLE |
|-------------------------|---------|------------------|--------------------|
| Head Rectangular Flange | F | MF1 | 1 1/2" - 8" |
| Cap Rectangular Flange | R | MF2 | 1 1/2" - 8" |
| Head Square Flange | J | MF5 | 1 1/2" - 8" |
| Cap Square Flange | S | MF6 | 1 1/2" - 8" |
| Integral Square Head | J | ** | 10" - 30" |
| Integral Square Cap | S | ** | 10" - 30" |
| Tie Rods Extended | L, N, M | MX1, MX2, MX3 | 1 1/2" - 8" |
| Head Rectangular | G | **ME5 | 1 1/2" - 14" |
| Cap Rectangular | P | **ME6 | 1 1/2" - 14" |
| No Mount | K | N/A | 1 1/2" - 30" |

** NFPA mounting dimensions are available on all cylinders 1 1/2" - 8" bore. For larger cylinders, see pages 11-19 for mounting dimensions.

N5 Series Mounting Dimensions

1½"-8" bore cylinders

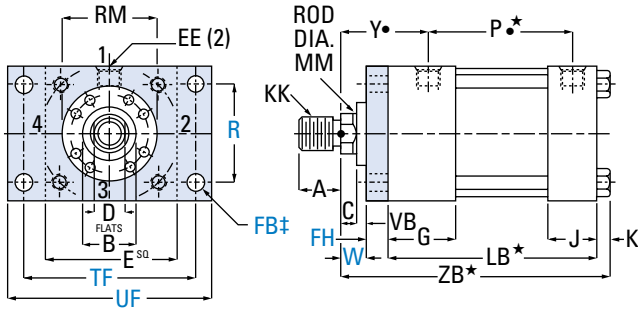

N5F – Head Rectangular Flange Mount (NFA Style MF1)

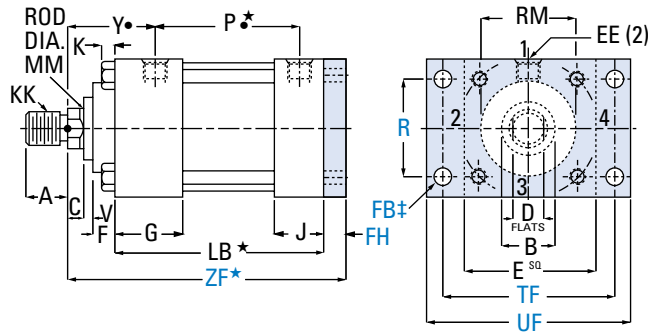

N5R – Cap Rectangular Flange Mount (NFA Style MF2)

MAXIMUM OPERATING PRESSURES IN PSI FOR F MOUNTING IN PUSH

| CYLINDER BORE | STANDARD ROD2:1 PISTON ROD | | | |
|---------------|----------------------------|----------|------------|----------|
| | Heavy Duty | Nonshock | Heavy Duty | Nonshock |
| 5 & 6 | 1440 | 2400 | 1120 | 1840 |
| 7 | 1040 | 1760 | 720 | 1200 |
| 8 | 800 | 1350 | 640 | 1120 |

MAXIMUM OPERATING PRESSURES IN PSI FOR R MOUNTING IN PULL

| CYLINDER BORE | STANDARD ROD2:1 PISTON ROD | | | |
|---------------|----------------------------|----------|------------|-----------|
| | Heavy Duty | Nonshock | Heavy Duty | Non-shock |
| 5 & 6 | 1800 | 3000 | 1400 | 2300 |
| 7 | 1300 | 2200 | 900 | 1500 |
| 8 | 1000 | 1700 | 800 | 1400 |

Note

When pressure must exceed the limitations above for mountings F and R, specify J or S mounting. (Up to a maximum of 3000 psi heavy duty, 5000 psi nonshock).

N5 Series Mounting Dimensions

1½"-8" bore cylinders

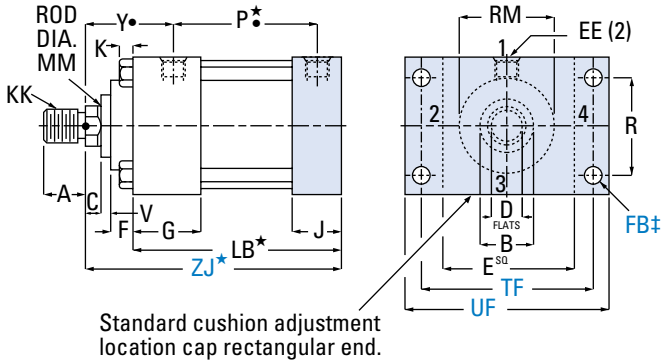

N5P – Cap Rectangular Mount (NFPA Style ME6)

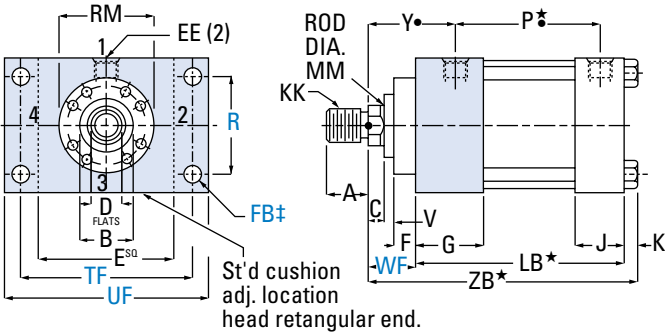

N5G – Head Rectangular Mount (NFPA Style ME5)

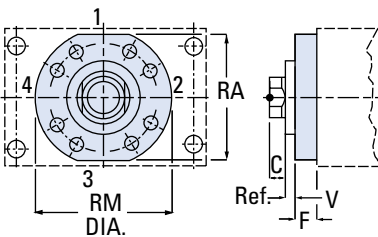

Mounting G Only

Note

Use the chart below for the cartridge retainer plate dimensions for the bore and rod combinations listed. See page 13 for all other mounting dimensions.

G MOUNTING

| BORE | ROD DIAG. | F | RA | RM | V |
|------|-----------|-------|------|-------|-------|
| 1½ | 5/8 | 11/32 | - | 2³/₈ | 9/32 |
| | 1 | 1/2 | 2.44 | 2⁵/₈ | 3/8 |
| 2 | 1 | 1/2 | - | 2⁵/₈ | 3/8 |
| | 1³/₈ | 19/32 | 2.94 | 3¼ | 13/32 |
| 2½ | 1³/₈ | 19/32 | - | 3¼ | 13/32 |
| | 1¾ | 19/32 | 3.44 | 3⁷/₈ | 17/32 |
| 3¼ | 1¾ | 19/32 | - | 3⁷/₈ | 17/32 |
| | 2 | 19/32 | 4 | 17/32 | |

N5 Series Mounting Dimensions

End Mountings

(See important application data on pages 20-23.)

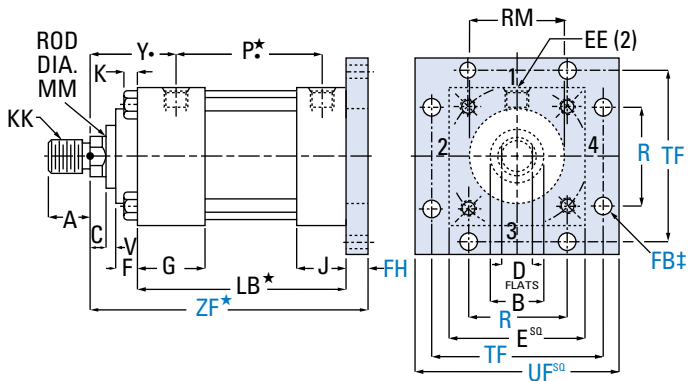

N5S – Cap Square Flange Mount (NFFA Style MF6)

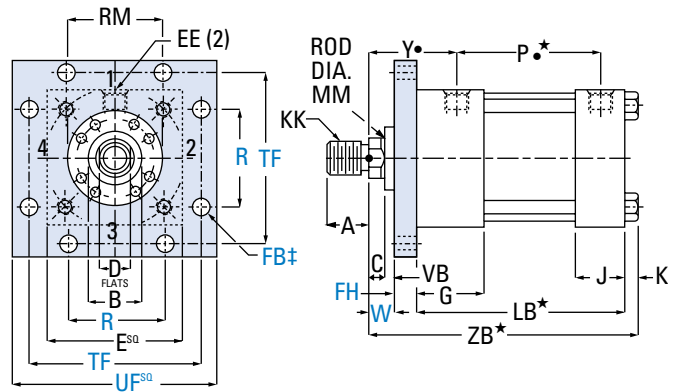

N5J – Head Square Flange Mount (NFFA Style MF5)

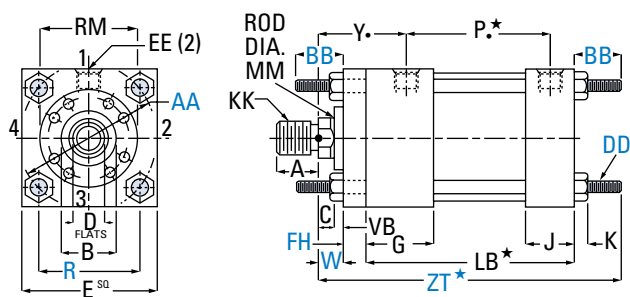

N5K (No Mount), N5L (NFFA Style MX1), N5N (NFFA Style MX2),

N5M (NFFA Style MX3) – Tie Rods Extended Mounts

- K – No Mount
 - (MX1) L – Both tie rods extended
 - (MX2) N – Cap end tie rods extended
 - (MX3) M – Head end tie rods extended
- Note
Mounting styles L and M use filler plate at the head end when cylinder has circular retainer.

CYLINDER DIMENSIONS

| BORE | 1 1/2 | 2 | 2 1/2 | 3 1/4 | 4 | 5 | 6 | 7 | 8 |
|------------------|----------|---------|---------|----------|----------|----------|----------|----------|----------|
| A | 3/4 | 1 1/8 | 1 1/8 | 1 5/8 | 2 | 2 1/4 | 3 | 3 1/2 | 3 1/2 |
| AA | 2.3 | 2.9 | 3.6 | 4.6 | 5.4 | 7.0 | 8.1 | 9.3 | 10.6 |
| AC | 1 1/8 | 1 1/2 | 1 1/2 | 1 3/4 | 2 | 2 5/8 | 3 1/4 | 3 3/4 | 4 3/8 |
| AD | 5/8 | 15/16 | 15/16 | 1 1/16 | 1 5/16 | 1 11/16 | 1 15/16 | 2 7/16 | 2 11/16 |
| AE | 1/4 | 3/8 | 3/8 | 3/8 | 1/2 | 5/8 | 3/4 | 7/8 | 1 |
| AF | 3/8 | 1 1/16 | 1 1/16 | 7/8 | 1 1/8 | 1 3/8 | 1 3/4 | 2 1/4 | 2 1/2 |
| B -.001 -.003 | 1 1/8 | 1 1/2 | 1 1/2 | 2 | 2 3/8 | 2 5/8 | 3 1/8 | 3 3/4 | 4 1/4 |
| BB | 1 3/8 | 1 13/16 | 1 13/16 | 2 5/16 | 2 5/16 | 3 3/16 | 3 5/8 | 4 1/8 | 4 1/2 |
| C | 3/8 | 1/2 | 1/2 | 5/8 | 3/4 | 7/8 | 1 | 1 | 1 |
| CC | 1 1/2-20 | 7/8-14 | 7/8-14 | 1 1/4-12 | 1 1/2-12 | 1 3/4-12 | 2 1/4-12 | 2 3/4-12 | 3 1/4-12 |
| D | 17/32 | 7/8 | 7/8 | 1 1/8 | 1 1/2 | 1 3/4 | 2 1/8 | 2 5/8 | 3 |
| DD | 3/8-24 | 1/2-20 | 1/2-20 | 5/8-18 | 5/8-18 | 7/8-14 | 1-14 | 1 1/8-12 | 1 1/4-12 |
| E | 2 1/2 | 3 | 3 1/2 | 4 1/2 | 5 | 6 1/2 | 7 1/2 | 8 1/2 | 9 1/2 |
| EE (SAE) | 10 | 10 | 10 | 12 | 12 | 12 | 16 | 20 | 24 |
| EE (NPTF) | 1/2 | 1/2 | 1/2 | 3/4 | 3/4 | 3/4 | 1 | 1 1/4 | 1 1/2 |
| F | ▲ | ▲ | 1/2 | 19/32 | 19/32 | 19/32 | 19/32 | 23/32 | 23/32 |
| FB† | 7/16 | 9/16 | 9/16 | 1 1/16 | 1 1/16 | 1 5/16 | 1 1/16 | 1 3/16 | 1 5/16 |
| FH | 3/8 | 5/8 | 5/8 | 3/4 | 7/8 | 7/8 | 1 | 1 | 1 |
| FT | 5/8-18 | 1-14 | 1-14 | 1 3/8-12 | 1 3/4-12 | 2-12 | 2 1/2-12 | 3-12 | 3 1/2-12 |
| G | 1 3/4 | 1 3/4 | 1 3/4 | 2 | 2 | 2 | 2 1/4 | 2 3/4 | 3 |
| J | 1 1/2 | 1 1/2 | 1 1/2 | 1 3/4 | 1 3/4 | 1 3/4 | 2 1/4 | 2 3/4 | 3 |
| K | 3/8 | 7/16 | 7/16 | 9/16 | 9/16 | 13/16 | 15/16 | 1 | 1 1/8 |
| KK | 7/16-20 | 3/4-16 | 3/4-16 | 1-14 | 1 1/4-12 | 1 1/2-12 | 1 7/8-12 | 2 1/4-12 | 2 1/2-12 |
| LB* | 4 5/8 | 4 5/8 | 4 3/4 | 5 1/2 | 5 3/4 | 6 1/4 | 7 3/8 | 8 1/2 | 9 1/2 |
| MM | 5/8 | 1 | 1 | 1 3/8 | 1 3/4 | 2 | 2 1/2 | 3 | 3 1/2 |
| P* | 2 11/16 | 2 11/16 | 2 13/16 | 3 9/16 | 3 13/16 | 4 5/16 | 4 11/16 | 5 1/8 | 5 7/8 |
| R | 1.63 | 2.05 | 2.55 | 3.25 | 3.82 | 4.95 | 5.73 | 6.58 | 7.50 |
| RM | ■ | ■ | 2 5/8 | 3 1/4 | 3 7/8 | 4 | 4 7/16 | 5 1/4 | 5 5/8 |
| TF | 3 7/16 | 4 1/8 | 4 5/8 | 5 7/8 | 6 3/8 | 8 3/16 | 9 7/16 | 10 5/8 | 11 13/16 |
| UF | 4 1/4 | 5 1/8 | 5 5/8 | 7 1/8 | 7 5/8 | 9 3/4 | 11 1/4 | 12 5/8 | 14 |
| V | ▲ | ▲ | 3/8 | 13/32 | 17/32 | 17/32 | 2 1/32 | 17/32 | 17/32 |
| VB | 1/4 | 1/4 | 1/4 | 1/4 | 1/4 | 1/4 | 1/4 | 1/4 | 1/4 |
| W | 5/8 | 3/4 | 3/4 | 7/8 | 1 | 1 1/8 | 1 1/4 | 1 1/4 | 1 1/4 |
| WF | 1 | 1 3/8 | 1 3/8 | 1 5/8 | 1 7/8 | 2 | 2 1/4 | 2 1/4 | 2 1/4 |
| Y• | 2 15/32 | 2 15/32 | 2 15/32 | 2 23/32 | 2 31/32 | 3 3/32 | 3 19/32 | 3 15/16 | 4 1/16 |
| ZB* | 6 | 6 7/16 | 6 9/16 | 7 11/16 | 8 3/16 | 9 1/16 | 10 9/16 | 11 3/4 | 12 7/8 |
| ZF* | 6 | 6 5/8 | 6 3/4 | 7 7/8 | 8 1/2 | 9 1/8 | 10 5/8 | 11 3/4 | 12 3/4 |
| ZJ* | 5 5/8 | 6 | 6 1/8 | 7 1/8 | 7 5/8 | 8 1/4 | 9 5/8 | 10 3/4 | 11 3/4 |
| ZT* | 7 | 7 13/16 | 7 15/16 | 9 7/16 | 9 15/16 | 11 7/16 | 13 1/4 | 14 7/8 | 16 1/4 |
| PISTON THICKNESS | 1 3/8 | 1 3/8 | 1 1/2 | 1 3/4 | 2 | 2 1/2 | 2 7/8 | 3 | 3 1/2 |

Dimensions shown in blue are mounting dimensions.

Over-size rods affect dimensions in blue-shaded areas. See pages 36-37 for these dimensions.

★ Add stroke to all starred dimensions.
■ Refer to page 27.

Note - Additional port information on page 26.

▲ Use FH dimension in place of F dimension and VB dimension in place of V dimension.

† Use screws 1/16" smaller than mounting holes.

• Port dimensions for standard ports only. Consult Eaton for flange, manifold and special ports.

Note - Overall length dimensions that require addition of stroke may vary from dimensions shown, due to manufacturing tolerances.

N5 Series Mounting Dimensions

1½"-8" bore cylinders

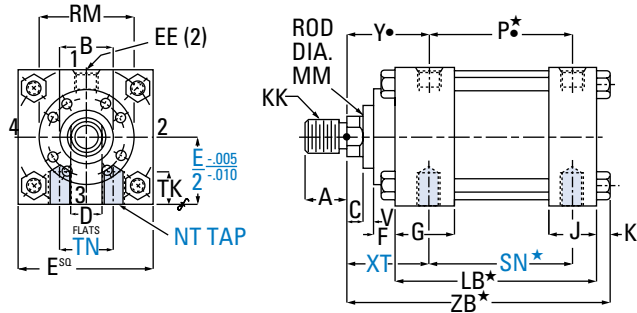

N5B – Side Tapped Mount (NFPA Style MS4)

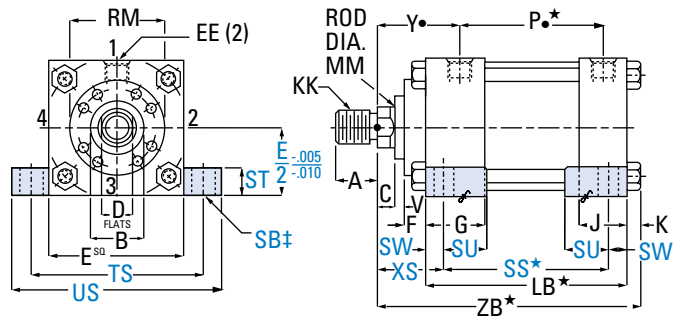

Note

See page 17 for double rod cylinder mounting dimensions.

N5A – Side Lugs Mount (NFPA Style MS2)

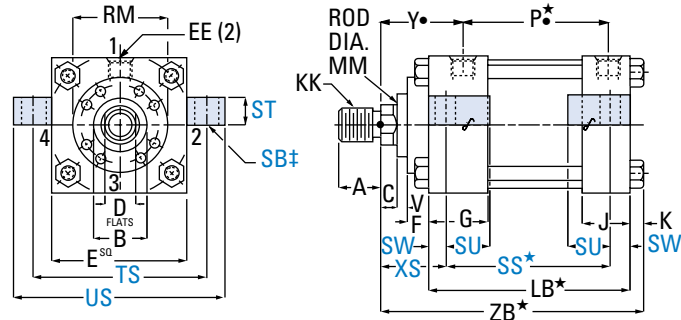

Note

See page 17 for double rod cylinder mounting dimensions.

N5H – Center-Line Lugs Mount (NFPA Style MS3)

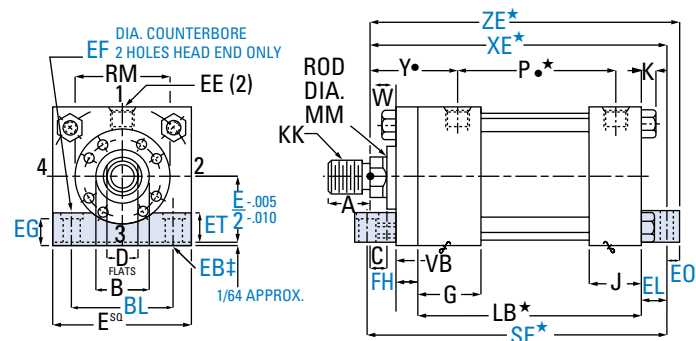

Note

See page 17 for double rod cylinder mounting dimensions.

Note

Port at Position 3 not available on 1½", 2", 2½", 3¼" and 4" bore.

Note

Bottoms of heads and caps are mounting surfaces. Lugs hold cylinders against mounting surface.

N5E – Side End Lugs (NFPA Style MS7)

N5 Series Mounting Dimensions

Side- and Center-line
Mountings

(See important application
data on pages 20-23)

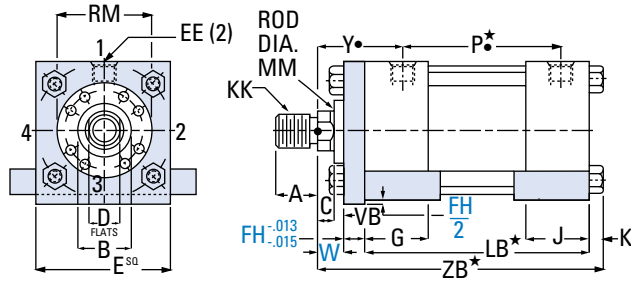

N5 – Extended Key Plate – Available when specified

Note

To order, specify extended key plate after the N5 series and mounting style (Example: N5A with extended key plate).

Dimensions shown in blue are mounting dimensions.

○ Oversize rods affect dimensions in blue-shaded areas. See pages 36-37 for these dimensions.

- ★ Add stroke to all starred dimensions.
- Refer to page 27.

Note - Overall length dimensions that require addition of stroke may vary from dimensions shown, due to manufacturing tolerances.

- ▲ Use FH dimension in place of F dimension and VB dimension in place of V dimension.
- † Use screws 1/16" smaller than mounting holes.
- Port dimensions for standard ports only. Consult Eaton for flange, manifold and special ports.

CYLINDER DIMENSIONS

| BORE | 1 1/2 | 2 | 2 1/2 | 3 1/4 | 4 | 5 | 6 | 7 | 8 |
|-------------------|----------|---------|---------|----------|----------|----------|----------|----------|----------|
| A | 3/4 | 1 1/8 | 1 1/8 | 1 5/8 | 2 | 2 1/4 | 3 | 3 1/2 | 3 1/2 |
| AC | 1 1/8 | 1 1/2 | 1 1/2 | 1 3/4 | 2 | 2 5/8 | 3 1/4 | 3 3/4 | 4 3/8 |
| AD | 5/8 | 15/16 | 15/16 | 1 1/16 | 1 5/16 | 1 11/16 | 1 15/16 | 2 7/16 | 2 11/16 |
| AE | 1/4 | 3/8 | 3/8 | 3/8 | 1/2 | 5/8 | 3/4 | 7/8 | 1 |
| AF | 3/8 | 1 1/16 | 1 1/16 | 7/8 | 1 1/8 | 1 3/8 | 1 3/4 | 2 1/4 | 2 1/2 |
| B ⁻⁰⁰¹ | 1 1/8 | 1 1/2 | 1 1/2 | 2 | 2 3/8 | 2 5/8 | 3 1/8 | 3 3/4 | 4 1/4 |
| B ⁻⁰⁰³ | 1 1/8 | 1 1/2 | 1 1/2 | 2 | 2 3/8 | 2 5/8 | 3 1/8 | 3 3/4 | 4 1/4 |
| BL | 1.63 | 2.07 | 2.56 | 3.27 | 3.84 | 4.95 | 5.74 | 6.58 | 7.51 |
| C | 3/8 | 1/2 | 1/2 | 5/8 | 3/4 | 7/8 | 1 | 1 | 1 |
| CC | 1 1/2-20 | 7/8-14 | 7/8-14 | 1 1/4-12 | 1 1/2-12 | 1 3/4-12 | 2 1/4-12 | 2 3/4-12 | 3 1/4-12 |
| CD | 1 7/32 | 7/8 | 7/8 | 1 1/8 | 1 1/2 | 1 3/4 | 2 1/8 | 2 5/8 | 3 |
| E | 2 1/2 | 3 | 3 1/2 | 4 1/2 | 5 | 6 1/2 | 7 1/2 | 8 1/2 | 9 1/2 |
| EB† | 7/16 | 9/16 | 9/16 | 1 1/16 | 1 1/16 | 1 5/16 | 1 11/16 | 1 3 1/16 | 1 5 1/16 |
| EE (SAE) | 10 | 10 | 10 | 12 | 12 | 12 | 16 | 20 | 24 |
| EE (NPTF) | 1/2 | 1/2 | 1/2 | 3/4 | 3/4 | 3/4 | 1 | 1 1/4 | 1 1/2 |
| EF | 5/8 | 13/16 | 13/16 | 1 | 1 | 1 3/8 | 1 5/8 | 1 5/8 | 2 3/32 |
| EG | 1 1/16 | 3/4 | 3/4 | 1 1/16 | 7/8 | 1 1/4 | 1 1/2 | 1 1/2 | 1 3/4 |
| EL | 7/8 | 15/16 | 15/16 | 1 1/8 | 1 1/8 | 1 1/2 | 1 11/16 | 1 13/16 | 2 |
| EO | 3/8 | 1/2 | 1/2 | 5/8 | 5/8 | 3/4 | 7/8 | 1 | 1 1/8 |
| ET | 7/8 | 1 | 1 | 1 1/4 | 1 1/4 | 1 1/2 | 1 3/4 | 2 | 2 |
| F | ▲ | ▲ | 1/2 | 19/32 | 19/32 | 19/32 | 19/32 | 23/32 | 23/32 |
| FH | 3/8 | 5/8 | 5/8 | 3/4 | 7/8 | 7/8 | 1 | 1 | 1 |
| FT | 5/8-18 | 1-14 | 1-14 | 1 3/8-12 | 1 3/4-12 | 2-12 | 2 1/2-12 | 3-12 | 3 1/2-12 |
| G | 1 3/4 | 1 3/4 | 1 3/4 | 2 | 2 | 2 | 2 1/4 | 2 3/4 | 3 |
| J | 1 1/2 | 1 1/2 | 1 1/2 | 1 3/4 | 1 3/4 | 1 3/4 | 2 1/4 | 2 3/4 | 3 |
| K | 3/8 | 7/16 | 7/16 | 9/16 | 9/16 | 13/16 | 15/16 | 1 | 1 1/8 |
| KK | 7/16-20 | 3/4-16 | 3/4-16 | 1-14 | 1 1/4-12 | 1 1/2-12 | 1 7/8-12 | 2 1/4-12 | 2 1/2-12 |
| LB* | 4 5/8 | 4 5/8 | 4 3/4 | 5 1/2 | 5 3/4 | 6 1/4 | 7 3/8 | 8 1/2 | 9 1/2 |
| MM | 5/8 | 1 | 1 | 1 3/8 | 1 3/4 | 2 | 2 1/2 | 3 | 3 1/2 |
| NT | 3/8-16 | 1/2-13 | 5/8-11 | 3/4-10 | 1-8 | 1-8 | 1 1/4-7 | 1 1/2-6 | 1 1/2-6 |
| P* | 2 11/16 | 2 11/16 | 2 13/16 | 3 9/16 | 3 13/16 | 4 5/16 | 4 11/16 | 5 1/8 | 5 7/8 |
| RM | ■ | ■ | 2 5/8 | 3 1/4 | 3 7/8 | 4 | 4 7/16 | 5 1/4 | 5 5/8 |
| SB† | 7/16 | 9/16 | 13/16 | 13/16 | 1 1/16 | 1 1/16 | 1 5/16 | 1 9/16 | 1 9/16 |
| SE* | 6 3/4 | 7 1/8 | 7 1/4 | 8 1/2 | 8 7/8 | 10 1/8 | 11 3/4 | 13 1/8 | 14 1/2 |
| SN* | 2 7/8 | 2 7/8 | 3 | 3 1/2 | 3 3/4 | 4 1/4 | 5 1/8 | 5 7/8 | 6 5/8 |
| SS* | 3 7/8 | 3 5/8 | 3 3/8 | 4 1/8 | 4 | 4 1/2 | 5 1/8 | 5 3/4 | 6 3/4 |
| ST | 1/2 | 3/4 | 1 | 1 | 1 1/4 | 1 1/4 | 1 1/2 | 1 3/4 | 1 3/4 |
| SU | 15/16 | 1 1/4 | 1 9/16 | 1 9/16 | 2 | 2 | 2 1/2 | 2 7/8 | 2 7/8 |
| SW | 3/8 | 1/2 | 1 1/16 | 1 1/16 | 7/8 | 7/8 | 1 1/8 | 1 3/8 | 1 3/8 |
| TK | 9/16 | 1/2 | 13/16 | 3/4 | 1 | 1 1/8 | 1 5/16 | 2 1/8 | 1 9/16 |
| TN | 3/4 | 15/16 | 1 5/16 | 1 1/2 | 2 1/16 | 2 15/16 | 3 5/16 | 3 3/4 | 4 1/4 |
| TS | 3 1/4 | 4 | 4 7/8 | 5 7/8 | 6 3/4 | 8 1/4 | 9 3/4 | 11 1/4 | 12 1/4 |
| US | 4 | 5 | 6 1/4 | 7 1/4 | 8 1/2 | 10 | 12 | 14 | 15 |
| V | ▲ | ▲ | 3/8 | 13/32 | 17/32 | 17/32 | 21/32 | 17/32 | 17/32 |
| VB | 1/4 | 1/4 | 1/4 | 1/4 | 1/4 | 1/4 | 1/4 | 1/4 | 1/4 |
| W | 5/8 | 3/4 | 3/4 | 7/8 | 1 | 1 1/8 | 1 1/4 | 1 1/4 | 1 1/4 |
| XE* | 6 1/2 | 6 15/16 | 7 1/16 | 8 1/4 | 8 3/4 | 9 3/4 | 11 5/16 | 12 9/16 | 13 3/4 |
| XS | 1 3/8 | 1 7/8 | 2 1/16 | 2 5/16 | 2 3/4 | 2 7/8 | 3 3/8 | 3 5/8 | 3 5/8 |
| XT | 2 | 2 3/8 | 2 3/8 | 2 3/4 | 3 | 3 3/8 | 3 1/2 | 3 13/16 | 3 15/16 |
| Y• | 2 15/32 | 2 15/32 | 2 15/32 | 2 23/32 | 2 31/32 | 3 3/32 | 3 19/32 | 3 15/16 | 4 1/16 |
| ZB* | 6 | 6 7/16 | 6 9/16 | 7 11/16 | 8 3/16 | 9 1/16 | 10 9/16 | 11 3/4 | 12 7/8 |
| ZE* | 6 7/8 | 7 1/16 | 7 9/16 | 8 7/8 | 9 3/8 | 10 1/2 | 12 3/16 | 13 9/16 | 14 7/8 |
| PISTON THICKNESS | 1 3/8 | 1 3/8 | 1 1/2 | 1 3/4 | 2 | 2 1/4 | 2 7/8 | 3 | 3 1/2 |

N5 Series Mounting Dimensions

1 1/2"-8" bore cylinders

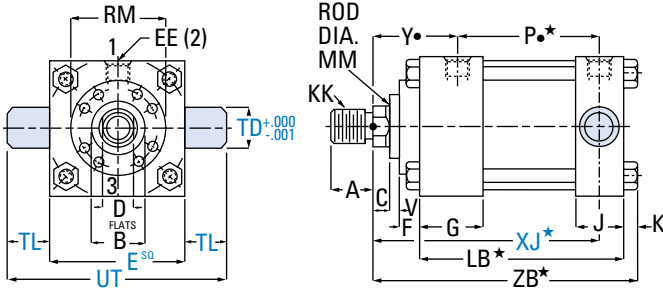

N5W – Cap Trunnion Mount (NFPA Style MT2)

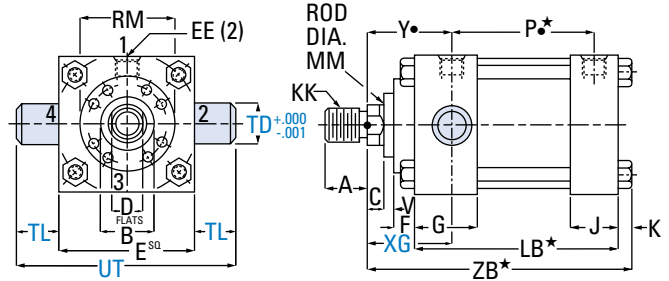

N5U – Head Trunnion Mount (NFPA Style MT1)

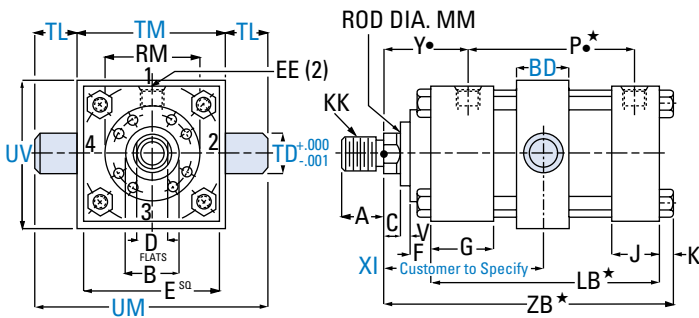

1 1/2" -5" bores have one-piece trunnion.

N5T – Intermediate Fixed Trunnion Mount (NFPA Style MT4)

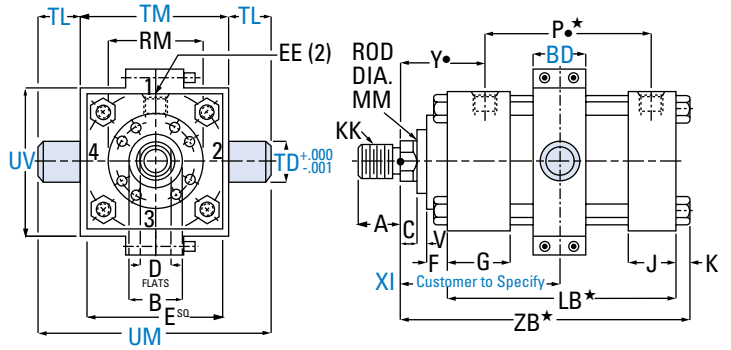

6" -8" bores have split trunnion.

N5TT – Intermediate Fixed Trunnion Mount (NFPA Style MT4)

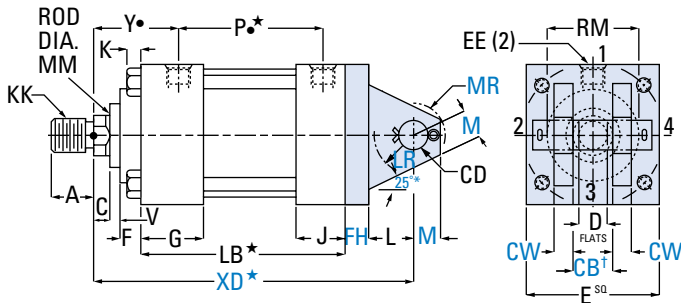

†Maximum width of mating part.

N5DC – Cap Detachable Clevis Mount (NFPA Style MP2)

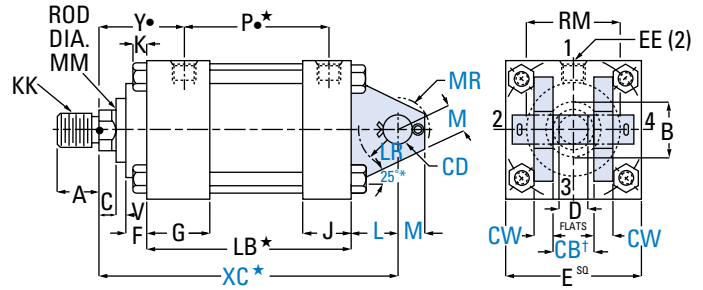

†Maximum width of mating part.

N5C – Cap Fixed Clevis Mount (NFPA Style MP1)

Pivot Mountings and Double Rod Cylinders

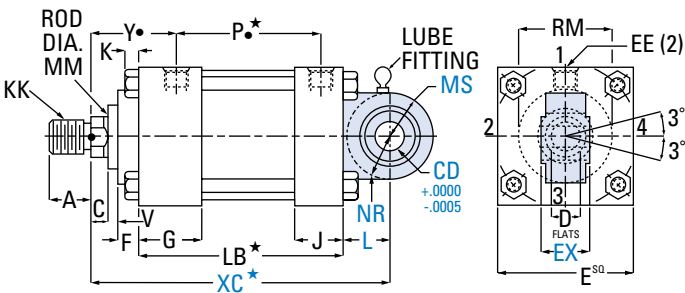

N5CS – Cap Spherical Bearing Mount

MAXIMUM OPERATING PRESSURE

| 1 1/2 | 2 | 2 1/2 | 3 1/4 | 4 | 5 | 6 |
|-------|------|-------|-------|------|------|------|
| 1650 | 2200 | 1400 | 1500 | 1750 | 1900 | 1700 |

N5 Series Mounting Dimensions

Pivot Mountings and Double Rod Cylinders (continued)

(See important application data on pages 20-23.)

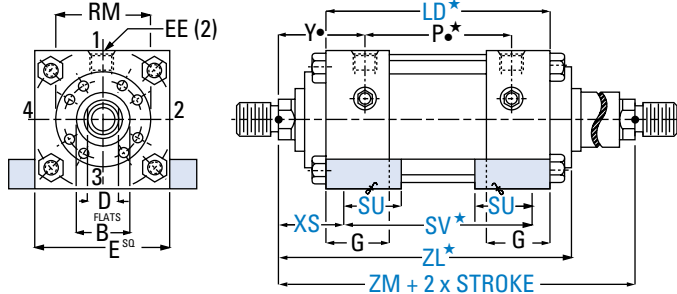

N5AD – Side Lugs Mount – Double Rod

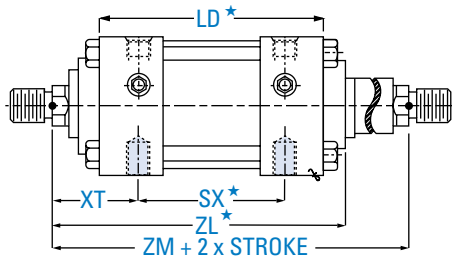

N5BD – Side Tapped Mount – Double Rod

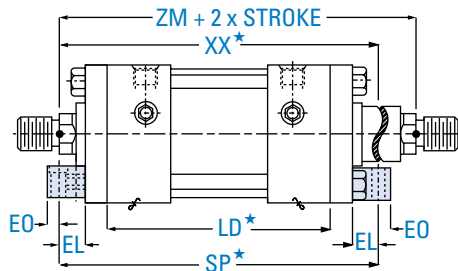

N5ED – Side End Lugs Mount – Double Rod

Note

N5HD has mounting dimensions identical to N5AD.

Note

Add D for double end after the N5 series and mounting style. (Example: N5AD)

Note

Dimensions not shown are same as single rod cylinders.

Note

Double rod cylinders available in all mounts except C, DC and W.

Dimensions shown in blue are mounting dimensions.

Note- Additional port information on pg 26.

○ Oversize rods affect dimensions in blue shaded areas. See pages 36-37 for these dimensions.

★ Add stroke to all starred dimensions.

■ Refer to page 27.

Note- Overall length dimensions that require addition of stroke may vary from dimensions shown, due to manufacturing tolerances.

▲ Use FH dimension in place of F dimension and VB dimension in place of V dimension.

‡ Plus 2X stroke.

• Port dimensions for standard ports only. Consult Eaton for flange, manifold and special ports

CYLINDER DIMENSIONS

| BORE | 1 1/2 | 2 | 2 1/2 | 3 1/4 | 4 | 5 | 6 | 7 | 8 |
|------------------|---------|---------|---------|----------|----------|----------|----------|----------|----------|
| A | 3/4 | 1 1/8 | 1 1/8 | 1 5/8 | 2 | 2 1/4 | 3 | 3 1/2 | 3 1/2 |
| AC | 1 1/8 | 1 1/2 | 1 1/2 | 1 3/4 | 2 | 2 5/8 | 3 1/4 | 3 3/4 | 4 3/8 |
| AD | 5/8 | 15/16 | 15/16 | 1 1/16 | 15/16 | 1 11/16 | 1 15/16 | 2 7/16 | 2 11/16 |
| AE | 1/4 | 3/8 | 3/8 | 3/8 | 1/2 | 5/8 | 3/8 | 7/8 | 1 |
| AF | 3/8 | 11/16 | 11/16 | 7/8 | 1 1/8 | 1 3/8 | 1 3/4 | 2 1/4 | 2 1/2 |
| B-001 | | | | | | | | | |
| -003 | 1 1/8 | 1 1/2 | 1 1/2 | 2 | 2 3/8 | 2 5/8 | 3 1/8 | 3 3/4 | 4 1/4 |
| BD | 1 1/2 | 1 1/2 | 1 1/2 | 2 | 2 | 2 1/2 | 3 | 3 | 3 1/2 |
| C | 3/8 | 1/2 | 1/2 | 5/8 | 3/4 | 7/8 | 1 | 1 | 1 |
| CB | 3/4 | 1 1/4 | 1 1/4 | 1 1/2 | 2 | 2 1/2 | 2 1/2 | 3 | 3 |
| CC | 1/2-20 | 7/8-14 | 7/8-14 | 1 1/4-12 | 1 1/2-12 | 1 3/4-12 | 2 1/4-12 | 2 3/4-12 | 3 1/4-12 |
| CD | 1/2 | 3/4 | 3/4 | 1 | 1 3/8 | 1 3/4 | 2 | 2 1/2 | 3 |
| CW | 1/2 | 5/8 | 5/8 | 3/4 | 1 | 1 1/4 | 1 1/4 | 1 1/2 | 1 1/2 |
| D | 17/32 | 7/8 | 7/8 | 1 1/8 | 1 1/2 | 1 3/4 | 2 1/8 | 2 5/8 | 3 |
| E | 2 1/2 | 3 | 3 1/2 | 4 1/2 | 5 | 6 1/2 | 7 1/2 | 8 1/2 | 9 1/2 |
| EE (NPTF) | 1/2 | 1/2 | 1/2 | 3/4 | 3/4 | 3/4 | 1 | 1 1/4 | 1 1/2 |
| EE (SAE) | 10 | 10 | 10 | 12 | 12 | 12 | 16 | 20 | 24 |
| EL | 7/8 | 15/16 | 15/16 | 1 1/8 | 1 1/8 | 1 1/2 | 1 11/16 | 1 13/16 | 2 |
| EO | 3/8 | 1/2 | 1/2 | 5/8 | 5/8 | 3/4 | 7/8 | 1 | 1 1/8 |
| EX | 7/16 | 2 1/32 | 2 1/32 | 7/8 | 1 3/16 | 1 17/32 | 1 3/4 | - | - |
| F | ▲ | ▲ | 1/2 | 19/32 | 19/32 | 19/32 | 19/32 | 23/32 | 23/32 |
| FH | 3/8 | 5/8 | 5/8 | 3/4 | 7/8 | 7/8 | 1 | 1 | 1 |
| FT | 5/8-18 | 1-14 | 1-14 | 1 3/8-12 | 1 3/4-12 | 2-12 | 2 1/2-12 | 3-12 | 3 1/2-12 |
| G | 1 3/4 | 1 3/4 | 1 3/4 | 2 | 2 | 2 | 2 1/4 | 2 3/4 | 3 |
| J | 1 1/2 | 1 1/2 | 1 1/2 | 1 3/4 | 1 3/4 | 1 3/4 | 2 1/4 | 2 3/4 | 3 |
| K | 3/8 | 7/16 | 7/16 | 9/16 | 9/16 | 13/16 | 15/16 | 1 | 1 1/8 |
| KK | 7/16-20 | 3/4-16 | 3/4-16 | 1-14 | 1 1/4-12 | 1 1/2-12 | 1 7/8-12 | 2 1/4-12 | 2 1/2-12 |
| L | 3/4 | 1 1/4 | 1 1/4 | 1 1/2 | 2 1/8 | 2 1/4 | 2 1/2 | 3 | 3 1/4 |
| LB* | 4 5/8 | 4 5/8 | 4 3/4 | 5 1/2 | 5 3/4 | 6 1/4 | 7 3/8 | 8 1/2 | 9 1/2 |
| LD* | 4 7/8 | 4 7/8 | 5 | 5 3/4 | 6 | 6 1/2 | 7 3/8 | 8 1/2 | 9 1/2 |
| LR | 9/16 | 1 1/16 | 1 1/16 | 1 1/4 | 1 7/8 | 1 15/16 | 2 1/16 | 2 9/16 | 2 11/16 |
| M | 1/2 | 3/4 | 3/4 | 1 | 1 3/8 | 1 3/4 | 2 | 2 1/2 | 2 3/4 |
| MM | 5/8 | 1 | 1 | 1 3/8 | 1 3/4 | 2 | 2 1/2 | 3 | 3 1/2 |
| MR | 9/16 | 1 1/16 | 1 1/16 | 1 1/8 | 1 3/4 | 1 7/8 | 2 1/8 | 2 1/2 | 2 3/4 |
| MS | 15/16 | 1 3/8 | 1 3/8 | 1 11/16 | 2 7/16 | 2 7/8 | 3 5/16 | - | - |
| NR | 5/8 | 1 | 1 | 1 1/4 | 1 5/8 | 2 1/16 | 2 3/8 | - | - |
| P* | 2 11/16 | 2 11/16 | 2 13/16 | 3 9/16 | 3 13/16 | 4 5/16 | 4 11/16 | 5 1/8 | 5 7/8 |
| RM | ■ | ■ | 2 5/8 | 3 1/4 | 3 7/8 | 4 | 4 7/16 | 5 1/4 | 5 3/8 |
| SP* | 7 3/8 | 8 | 8 1/8 | 9 1/2 | 10 | 11 1/4 | 12 3/4 | 14 1/8 | 15 1/2 |
| SU | 15/16 | 1 1/4 | 1 9/16 | 1 9/16 | 2 | 2 | 2 1/2 | 2 7/8 | 2 7/8 |
| SV* | 4 1/8 | 3 7/8 | 3 5/8 | 4 3/8 | 4 1/4 | 4 3/4 | 5 1/8 | 5 3/4 | 6 3/4 |
| SX* | 2 7/8 | 2 7/8 | 3 | 3 1/2 | 3 3/4 | 4 1/4 | 4 7/8 | 5 3/8 | 6 1/8 |
| TD | 1 | 1 3/8 | 1 3/8 | 1 3/4 | 1 3/4 | 1 3/4 | 2 | 2 1/2 | 3 |
| TL | 1 | 1 3/8 | 1 3/8 | 1 3/4 | 1 3/4 | 1 3/4 | 2 | 2 1/2 | 3 |
| TM | 3 | 3 1/2 | 4 | 5 | 5 1/2 | 7 | 8 1/2 | 9 3/4 | 11 |
| UM | 5 | 6 1/4 | 6 3/4 | 8 1/2 | 9 | 10 1/2 | 12 1/2 | 14 3/4 | 17 |
| UT | 4 1/2 | 5 3/4 | 6 1/4 | 8 | 8 1/2 | 10 | 11 1/2 | 13 1/2 | 15 1/2 |
| UV | 2 3/4 | 3 3/8 | 3 7/8 | 4 7/8 | 5 1/2 | 7 1/4 | 9 1/2 | 11 1/2 | 13 1/4 |
| V | ▲ | ▲ | 3/8 | 13/32 | 17/32 | 17/32 | 2 1/32 | 17/32 | 17/32 |
| VB | 1/4 | 1/4 | 1/4 | 1/4 | 1/4 | 1/4 | 1/4 | 1/4 | 1/4 |
| W | 5/8 | 3/4 | 3/4 | 7/8 | 1 | 1 1/8 | 1 1/4 | 1 1/4 | 1 1/4 |
| XC* | 6 3/8 | 7 1/4 | 7 3/8 | 8 5/8 | 9 3/4 | 10 1/2 | 12 1/8 | 13 3/4 | 15 |
| XD* | 6 3/4 | 7 7/8 | 8 | 9 3/8 | 10 5/8 | 11 3/8 | 13 1/8 | 14 3/4 | 16 |
| XG | 1 7/8 | 2 1/4 | 2 1/4 | 2 5/8 | 2 7/8 | 3 | 3 3/8 | 3 5/8 | 3 3/4 |
| XJ* | 4 7/8 | 5 1/4 | 5 3/8 | 6 1/4 | 6 3/4 | 7 3/8 | 8 3/8 | 9 3/8 | 10 1/4 |
| XS | 1 3/8 | 1 7/8 | 2 1/16 | 2 5/16 | 2 3/4 | 2 7/8 | 3 3/8 | 3 5/8 | 3 5/8 |
| XT | 2 | 2 3/8 | 2 3/8 | 2 3/4 | 3 | 3 1/8 | 3 1/2 | 3 13/16 | 3 15/16 |
| XX* | 7 1/8 | 7 13/16 | 7 15/16 | 9 1/4 | 9 7/8 | 10 7/8 | 12 5/16 | 13 9/16 | 14 3/4 |
| Y• | 2 15/32 | 2 15/32 | 2 15/32 | 2 23/32 | 2 31/32 | 3 3/32 | 3 19/32 | 3 15/32 | 4 1/16 |
| ZB* | 6 | 6 7/16 | 6 9/16 | 7 11/16 | 8 3/16 | 9 1/16 | 10 9/16 | 11 3/4 | 12 7/8 |
| ZL* | 6 1/4 | 6 7/8 | 6 7/8 | 7 31/32 | 8 15/32 | 9 3/32 | 10 7/32 | 11 15/32 | 12 15/32 |
| ZM** | 6 7/8 | 7 5/8 | 7 3/4 | 9 | 9 3/4 | 10 1/2 | 11 7/8 | 13 | 14 |
| PISTON THICKNESS | 1 3/8 | 1 3/8 | 1 1/2 | 1 3/4 | 2 | 2 1/4 | 2 7/8 | 3 | 3 1/2 |

N5 Series Mounting Dimensions

10"-20", 24" and 30" bore
cylinders

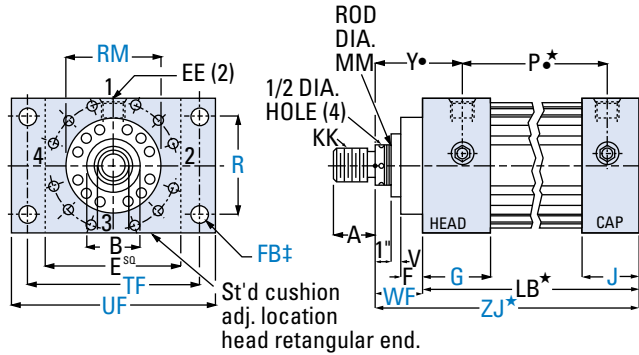

N5G – Head Rectangular Mount
N5P – Cap Rectangular Mount

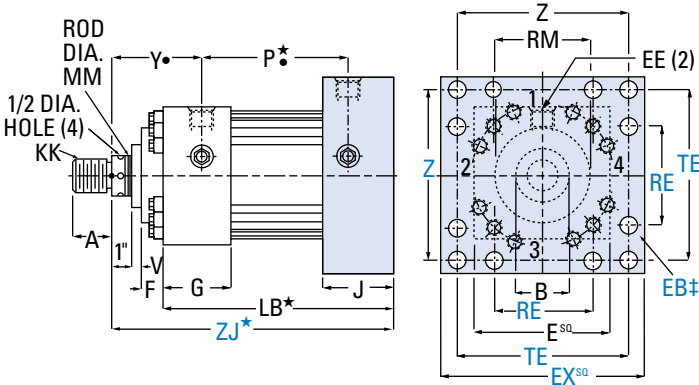

N5S – Cap Square Mount

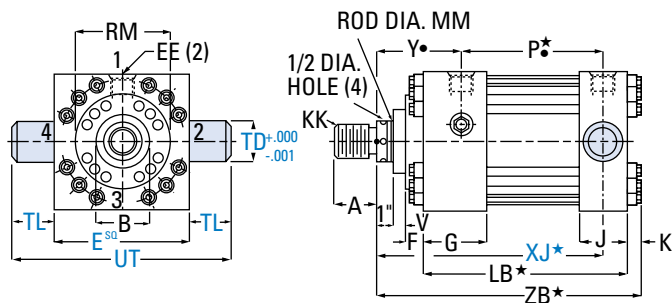

N5W – Cap Trunnion Mount

Note

Tie rod nuts will extend past the end cap K thickness on the end opposite flange mounting.

Available in 10", 12" and 14" bores only.

Over 14" bore, use J or S mount.

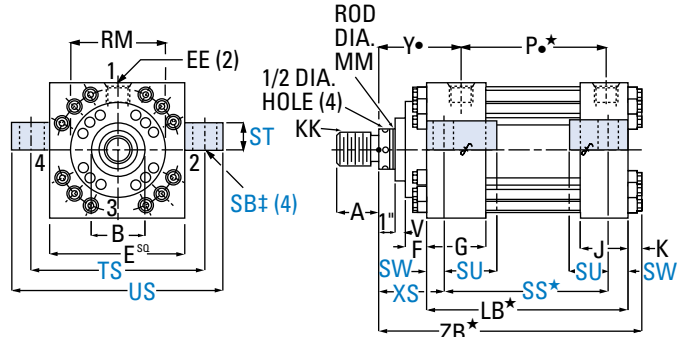

N5H – Center-line Lugs Mount

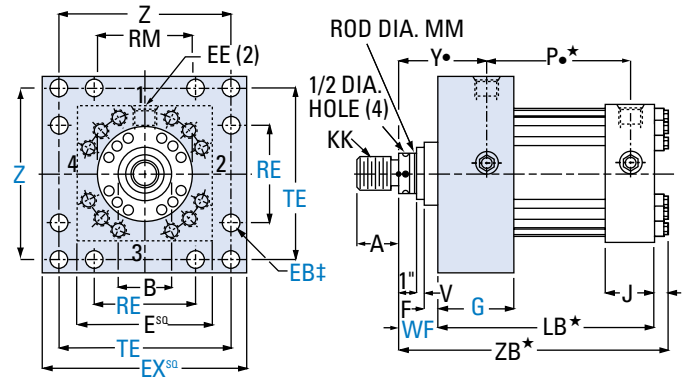

N5J – Head Square Mount

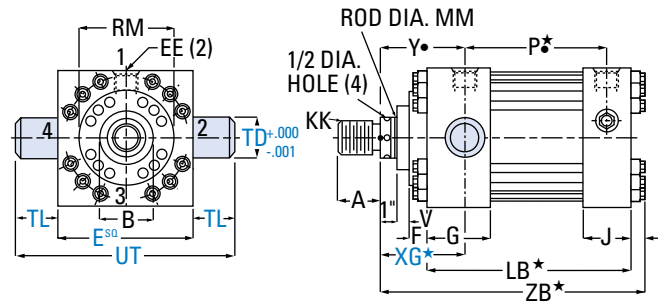

N5U – Head Trunnion Mount

N5 Series Mounting Dimensions

All Mountings

(See important application data on pages 20-23.)

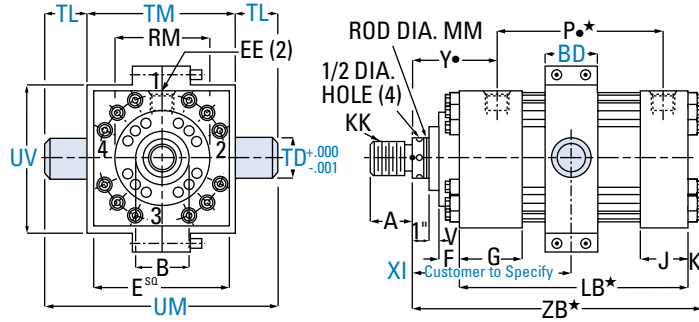

For trunnion dimensions over 14" bore, consult factory.

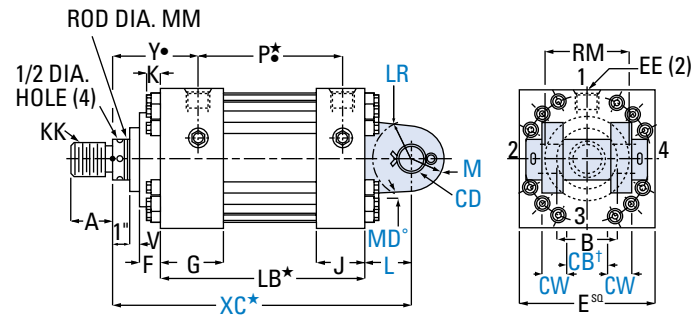

† Maximum width of mating part.

N5C – Cap Fixed Clevis Mount

Dimensions shown in blue are mounting dimensions.

■ Oversize rods affect dimensions in blue-shaded areas. See pages 36-37 for these dimensions.

★ Add stroke to all starred dimensions.

† Maximum width of mating part.

‡ Use screws 1/16" smaller than mounting holes.

Note- Overall length dimensions that require addition of stroke may vary from dimensions shown, due to manufacturing tolerances.

- Port dimensions for standard ports only. Consult Eaton for flange, manifold and special ports.

CYLINDER DIMENSIONS

| BORE | 10 | 12 | 14 | 16 | 18 | 20 | 24 | 30 |
|------------------|-------------|----------|----------|----------|----------|----------|---------|----------|
| A | 4 1/2 | 5 1/2 | 7 | 8 | 9 | 10 | 11 | 14 |
| AC | 5 1/4 | 6 1/4 | 6 1/2 | 6 1/2 | 6 3/4 | 7 1/4 | - | - |
| AD | 3 3/16 | 3 15/16 | 4 1/16 | 4 1/16 | 4 1/8 | 4 5/8 | - | - |
| AE | 1 1/2 | 1 7/8 | 2 | 2 | 2 | 2 3/8 | - | - |
| AF | 3 1/2 | 4 3/8 | 5 3/4 | 6 1/2 | 7 1/4 | 8 | - | - |
| B-.001 -.003 | 5 1/4 | 6 1/4 | 8 | 9 | 10 | 11 | 12 | 15 |
| BD | 4 | 5 | 5 1/2 | - | - | - | - | - |
| CB† | 4 | 4 1/2 | 6 | 7 | 8 | 9 | 10 | 12 |
| CC | 4 1/4-12 | 5 1/4-12 | 6 1/2-12 | 7 1/2-12 | 8 1/2-12 | 9 1/2-12 | - | - |
| CD | 3 1/2 | 4 | 5 | 6 | 6 1/2 | 7 1/2 | 9 | 11 |
| CW | 2 | 2 1/4 | 3 | 3 1/2 | 4 | 4 1/2 | 5 | 6 |
| E | 12 5/8 | 14 7/8 | 17 1/8 | 19 1/4 | 22 | 23 5/8 | 31 | 37 1/2 |
| EB | 1 5/16 | 1 9/16 | 1 13/16 | 1 13/16 | 2 1/16 | 2 1/16 | 2 9/16 | 3 1/16 |
| EE | SEE PAGE 22 | | | | | | | |
| EX | 16 5/8 | 19 3/4 | 21 3/4 | 24 1/2 | 26 1/2 | 29 | 36 | 47 |
| F | 7/8 | 1 3/8 | 1 5/8 | 1 7/8 | 2 3/16 | 2 11/16 | 2 11/16 | 3 1/8 |
| FB‡ | 1 13/16 | 2 1/16 | 2 5/16 | - | - | - | - | - |
| FT | 4 1/2-12 | 5 1/2-12 | 7-12 | 8-12 | 9-12 | 10-12 | 11-12 | 14-12 |
| G | 3 11/16 | 4 7/16 | 4 7/8 | 5 7/8 | 6 7/8 | 7 7/8 | 10 | 12 3/8 |
| J | 3 11/16 | 4 7/16 | 4 7/8 | 5 7/8 | 6 7/8 | 7 7/8 | 10 | 12 3/8 |
| K | 1 5/8 | 1 13/16 | 1 13/16 | 2 | 2 | 2 | 3 | 3 1/2 |
| KK | 3 1/4-12 | 4-12 | 5-12 | 5 3/4-12 | 6 1/2-12 | 7 1/4-12 | 8-8 | 11-8 |
| L | 4 | 4 1/2 | 5 3/4 | 7 | 7 5/8 | 8 3/4 | 17 | 21 |
| LB* | 12 1/8 | 14 1/2 | 15 5/8 | 18 1/8 | 21 1/8 | 23 5/8 | 29 1/2 | 36 1/4 |
| LR | 3 3/8 | 3 7/8 | 4 3/16 | 4 3/4 | 5 1/16 | 6 3/16 | - | - |
| M | 3 1/2 | 4 | 5 | 6 | 6 1/2 | 7 1/2 | 9 | 11 |
| MD | 10° | 14° | 0 | 0 | 0 | 0 | 0 | 0 |
| MM | 4 1/2 | 5 1/2 | 7 | 8 | 9 | 10 | 11 | 14 |
| P*• | 8 1/8 | 9 1/2 | 9 7/8 | 11 | 12 | 12 1/2 | 18 | 21 15/16 |
| R | 9.62 | 11.45 | 13.26 | - | - | - | - | - |
| RE | 9.89 | 11.75 | 12.90 | 15.28 | 16.45 | 18.07 | 22.125 | 23.75 |
| RM | 7 1/8 | 8 3/8 | 10 13/16 | 12 3/8 | 13 1/8 | 14 5/8 | 16 | 19 |
| SB‡ | 1 9/16 | 1 9/16 | 2 5/16 | 2 9/16 | 2 13/16 | 3 1/16 | - | - |
| SS* | 8 7/8 | 10 1/2 | 11 1/8 | 12 5/8 | 14 5/8 | 15 7/8 | - | - |
| ST | 2 1/4 | 3 | 4 | 4 1/2 | 5 1/4 | 6 1/2 | - | - |
| SU | 3 1/2 | 4 1/4 | 4 3/4 | 5 1/4 | 5 1/2 | 6 3/8 | - | - |
| SW | 1 5/8 | 2 | 2 1/4 | 2 3/4 | 3 1/4 | 3 7/8 | - | - |
| TD | 3 1/2 | 4 | 4 1/2 | 5 | 5 3/4 | 6 1/4 | 7 1/2 | 9 1/2 |
| TE | 14.13 | 16.79 | 18.43 | 21.03 | 22.65 | 24.87 | 31.25 | 40.75 |
| TF | 15 7/8 | 18 1/2 | 21 | - | - | - | - | - |
| TL | 3 1/2 | 4 | 4 1/2 | 5 | 5 3/4 | 6 1/4 | 7 1/2 | 9 1/2 |
| TM | 14 | 16 1/2 | 19 1/2 | - | - | - | - | - |
| TS | 15 7/8 | 18 7/8 | 21 5/8 | 24 1/4 | 27 1/2 | 30 3/8 | - | - |
| UF | 19 | 22 | 25 | - | - | - | - | - |
| UM | 21 | 24 1/2 | 28 1/2 | - | - | - | - | - |
| US | 19 1/8 | 22 7/8 | 26 1/8 | 29 1/4 | 33 | 36 5/8 | - | - |
| UT | 19 5/8 | 22 7/8 | 26 1/8 | 29 1/4 | 33 1/2 | 36 1/8 | 46 | 56 1/2 |
| UV | 17 1/2 | 20 3/4 | 24 3/4 | - | - | - | - | - |
| V | 1 1/16 | 1 3/16 | 7/8 | 1 1/8 | 1 1/16 | 1 3/16 | 1 3/16 | 3/8 |
| WF | 2 15/16 | 3 3/16 | 3 1/2 | 4 | 4 1/4 | 4 1/2 | 4 1/2 | 4 1/2 |
| XC* | 19 1/16 | 22 3/16 | 24 7/8 | 29 1/8 | 33 | 36 7/8 | 51 | 61 3/4 |
| XG | 4 3/4 | 5 3/8 | 5 15/16 | 6 15/16 | 7 11/16 | 8 7/16 | 9 1/2 | 10 3/4 |
| XJ* | 13 1/4 | 15 1/2 | 16 11/16 | 19 3/16 | 21 15/16 | 24 3/16 | 29 | 34 1/2 |
| XS | 4 9/16 | 5 3/16 | 5 3/4 | 6 3/4 | 7 1/2 | 8 3/8 | - | - |
| Y• | 4 15/16 | 5 11/16 | 6 3/8 | 7 9/16 | 8 13/16 | 10 1/16 | 10 1/4 | 11 7/16 |
| Z | - | - | - | - | - | - | - | 40 3/4 |
| ZB* | 16 11/16 | 19 1/2 | 20 15/16 | 24 1/8 | 27 3/8 | 30 1/8 | 37 | 44 1/4 |
| ZJ* | 15 1/16 | 17 11/16 | 19 1/8 | 22 1/8 | 25 3/8 | 28 1/8 | 34 | 40 3/4 |
| PISTON THICKNESS | 4 3/4 | 5 5/8 | 5 7/8 | 6 3/8 | 7 3/8 | 7 7/8 | 9 1/2 | 11 1/2 |

Tie Rod Information

10"- 20", 24" AND 30" BORE

| DIM | 10 | 12 | 14 | 16 | 18 | 20 | 24 | 30 |
|----------------|-----------------------------------|-----------------------------------|-----------------------------------|-----------------------------------|-----------------------------------|-----------------------------------|--------|-----------------------------------|
| RA | 5.291 | 6.270 | 7.485 | 8.086 | 9.589 | 10.437 | 13.589 | 16.585 |
| RB | 3.775 | 4.555 | 6.143 | 6.093 | 7.910 | 8.750 | 11.722 | 14.380 |
| RC | - | - | 4.409 | - | 5.761 | 6.649 | 9.158 | 11.439 |
| RD | - | - | - | - | - | - | 6.050 | 7.911 |
| TIE ROD THREAD | 1 ¹ / ₈ -12 | 1 ¹ / ₄ -12 | 1 ¹ / ₄ -12 | 1 ¹ / ₂ -12 | 1 ¹ / ₂ -12 | 1 ¹ / ₂ -12 | 2-12 | 2 ¹ / ₄ -12 |

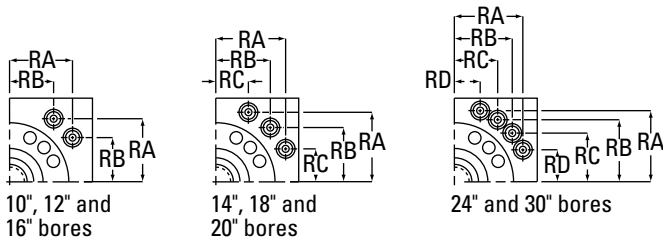

Note

The interchangeability of the 10"- 20", 24" and 30" bores with other cylinder brands has not been established by the NFPA. The above dimensions are Eaton Hydro-Line standards.

Technical Data

Rod Size and Stop tube selection

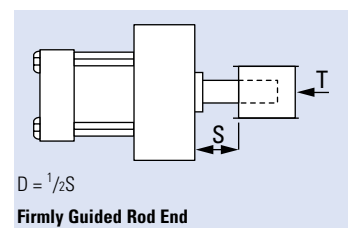
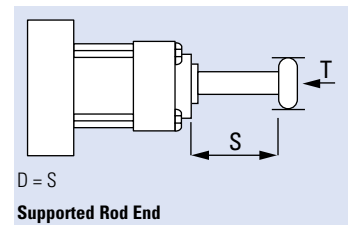
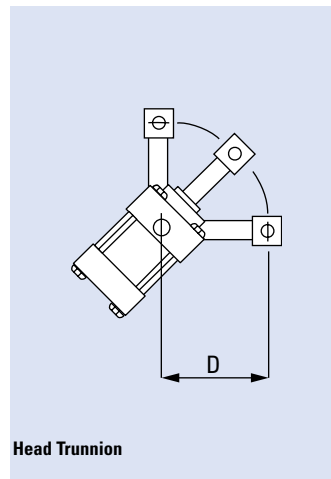
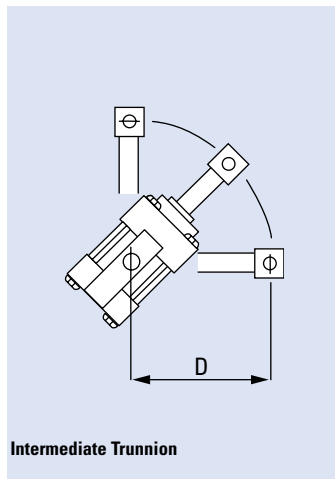
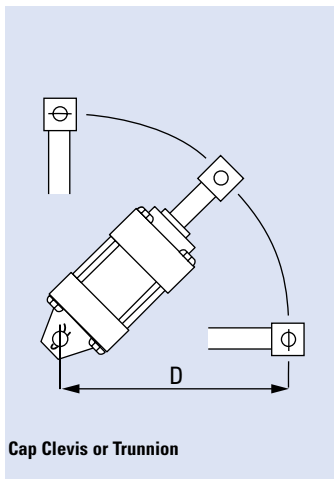
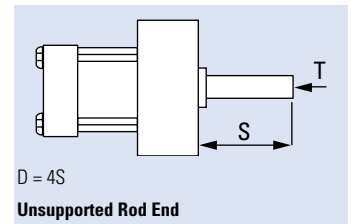
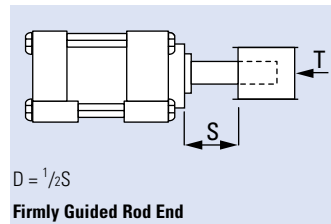
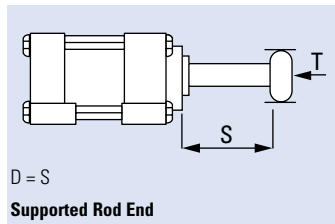
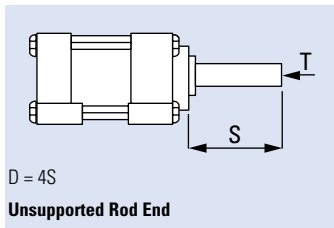

Technical Data

Rod Size and Stop Tube Selection (continued)

Rod Size Selection

Standard rod sizes are normally suitable for all applications except for long stroke or high thrust applications. Proper selection of minimum rod size may be determined by the following steps:

1. If you know the bore size and operating pressure, thrust can be determined. Refer to the graph in the next column.
2. Select from illustrations on page 20 the type of mounting needed, and determine the length of **D** with the piston rod in the fully extended position.
3. Find the value of **D** at the bottom of the graph and follow its line vertically until it intercepts the horizontal line, which represents the maximum push thrust to be applied to your cylinder. The intersection of these two lines will fall within a stripe representing the minimum recommended piston rod diameter for your needs.

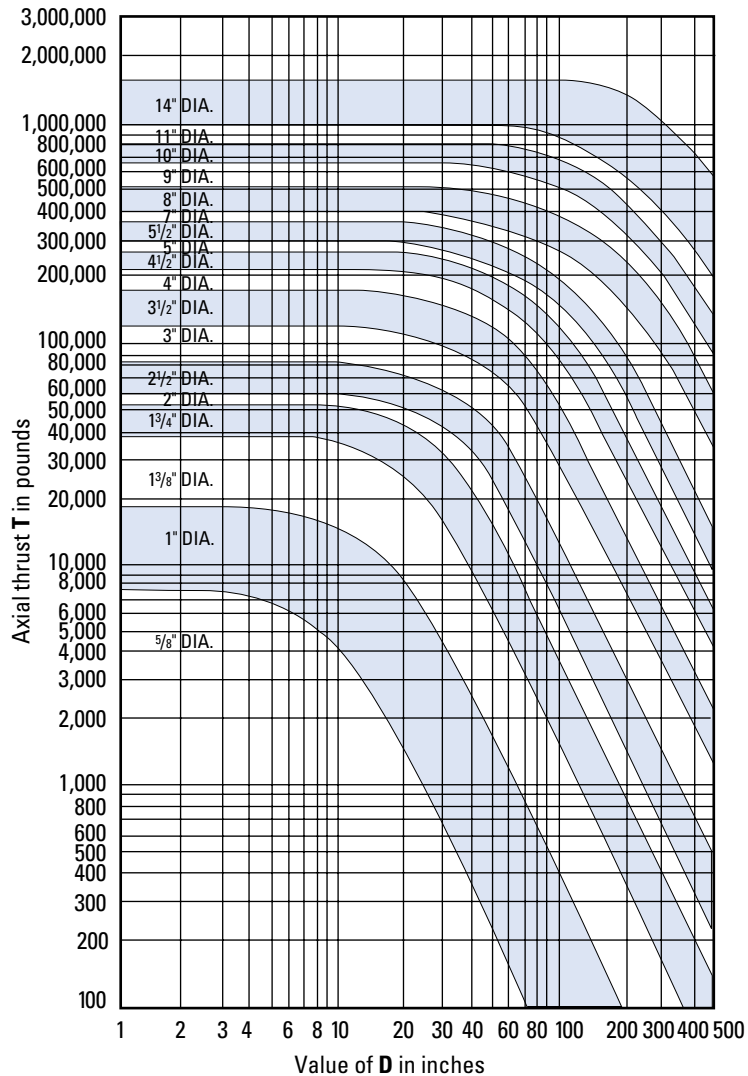

Stop Tubes

Stop tubes are located between the piston and the rod shoulder on the head end of the cylinder. Bearing loading is reduced by separating the piston and the rod bushing. Bearing wear and tendency to buckle is reduced.

To determine if a stop tube is required and the length of stop tube needed, use the following procedure:

Determine the value of **D** with the piston rod in the fully extended position. If the value of **D** is under 40", no stop tube is needed. If **D** is greater than 40", one inch of stop tube is recommended for each 10", or fraction thereof, beyond 40".

Special Note

When specifying stroke and stop tube lengths, please include net working stroke plus stop tube length.

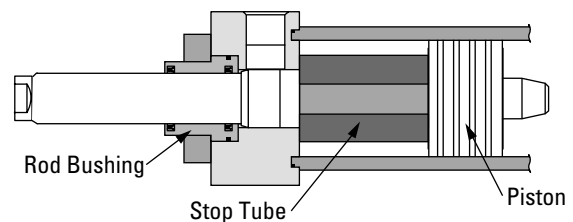

Technical Data

Pressure-Thrust
Consumption-Flow Charts

| Standard Operating Pressure Rating | | | | Out-Stroke Thrust In Pounds Force | | | | | | | | | | | | Consumption Per Inch Of Stroke in One Direction | | |
|------------------------------------|--------------|---------|---------------------|--|--------|--------|---------|---------|---------|---------|---------|----------|-----------|-----------|-----------|---|----------------------------------|--|
| Cyl. Bore in inches | Air AN5 LAN5 | Hyd. N5 | Piston Area sq. in. | Pressures of Operating Medium – Air or Hydraulic | | | | | | | | | | | | Oil Gallons Displaced | Air Pressure Cubic Ft. Displaced | Free Air Cubic Ft. at 80 psi Displaced |
| | | | | 50 psi | 60 psi | 80 psi | 100 psi | 200 psi | 250 psi | 500 psi | 750 psi | 1000 psi | 1500 psi | 2000 psi | 3000 psi | | | |
| 1 1/2 | 250 | 3000 | 1.84 | 92 | 110 | 147 | 184 | 368 | 460 | 920 | 1,380 | 1,840 | 2,760 | 3,680 | 5,520 | .00797 | .00106 | .00683 |
| 2 | 250 | 3000 | 3.24 | 162 | 194 | 259 | 324 | 648 | 810 | 1,620 | 2,430 | 3,240 | 4,860 | 6,480 | 9,720 | .01403 | .00188 | .01211 |
| 2 1/2 | 250 | 3000 | 5.03 | 252 | 302 | 402 | 503 | 1,006 | 1,258 | 2,520 | 3,773 | 5,030 | 7,545 | 10,060 | 15,090 | .02177 | .00291 | .01875 |
| 3 1/4 | 250 | 3000 | 8.45 | 423 | 507 | 676 | 845 | 1,690 | 2,113 | 4,230 | 6,338 | 8,450 | 12,675 | 16,900 | 25,350 | .03658 | .00489 | .03149 |
| 4 | 250 | 2700 | 12.76 | 638 | 766 | 1,021 | 1,276 | 2,552 | 3,190 | 6,380 | 9,570 | 12,760 | 19,140 | 25,520 | 38,280 | .05524 | .00738 | .04755 |
| 5 | 250 | 3000 | 19.87 | 994 | 1,192 | 1,590 | 1,987 | 3,974 | 4,968 | 9,940 | 14,903 | 19,870 | 29,805 | 39,740 | 59,610 | .08602 | .01150 | .07405 |
| 6 | 250 | 2700 | 28.56 | 1,428 | 1,714 | 2,285 | 2,856 | 5,712 | 7,140 | 14,280 | 21,420 | 28,560 | 42,840 | 57,120 | 85,680 | .12364 | .01653 | .10644 |
| 7 | 250 | 3000 | 38.82 | 1,941 | 2,329 | 3,106 | 3,882 | 7,764 | 9,705 | 19,410 | 29,115 | 38,820 | 58,230 | 77,640 | 116,460 | .16805 | .02247 | .14468 |
| 8 | 250 | 3000 | 50.64 | 2,532 | 3,038 | 4,051 | 5,064 | 10,128 | 12,660 | 25,320 | 37,980 | 50,640 | 75,960 | 101,280 | 151,920 | .21922 | .02931 | .18873 |
| 10 | 250 | 3000 | 79.01 | 3,951 | 4,741 | 6,321 | 7,901 | 15,802 | 19,753 | 39,510 | 59,258 | 79,010 | 118,515 | 158,020 | 237,030 | .34203 | .04572 | .29446 |
| 12 | 250 | 3000 | 113.66 | 5,683 | 6,820 | 9,093 | 11,366 | 22,732 | 28,415 | 56,830 | 85,245 | 113,660 | 170,490 | 227,320 | 340,980 | .49203 | .06578 | .42359 |
| 14 | 250 | 2700 | 154.60 | 7,730 | 9,276 | 12,368 | 15,460 | 30,920 | 38,650 | 77,300 | 115,950 | 154,600 | 231,900 | 309,200 | 463,800 | .66926 | .08947 | .57617 |
| 16 | 250 | 3000 | 201.82 | 10,091 | 12,109 | 16,146 | 20,182 | 40,364 | 50,455 | 109,910 | 151,365 | 201,820 | 302,730 | 403,640 | 605,460 | .87368 | .11679 | .75215 |
| 18 | 250 | 3000 | 255.32 | 12,766 | 15,319 | 20,426 | 25,532 | 51,064 | 63,830 | 127,660 | 191,490 | 255,320 | 382,980 | 510,640 | 765,960 | 1.10528 | .14775 | .95154 |
| 20 | 250 | 3000 | 315.10 | 15,755 | 18,906 | 25,208 | 31,510 | 63,020 | 78,775 | 157,550 | 236,325 | 315,100 | 472,650 | 630,200 | 945,300 | 1.36407 | .18235 | 1.17433 |
| 24 | 250 | 3000 | 453.12 | 22,676 | 27,211 | 36,282 | 45,352 | 90,704 | 113,380 | 226,760 | 340,140 | 513,210 | 684,280 | 1,026,420 | 1,539,630 | 1.96329 | .26245 | 1.69020 |
| 30 | 250 | 3000 | 708.27 | 35,414 | 42,496 | 56,662 | 70,827 | 141,654 | 177,068 | 354,140 | 531,210 | 796,820 | 1,062,405 | 1,416,540 | 2,124,810 | 3.06610 | .40988 | 2.63962 |

Below are cylinder sizes and their standard rod diameters (to the left). Consult bulletins for rods larger than standard.

Thrusts for pressures not shown in table, add the thrust for two or more operating pressures which combined equal the desired pressure.

1 Gallon = 231 Cubic Inches
Oil consumption gal. per min = Gal. per in. times in. per min. piston speed

Air consumption cubic ft. per min = Cu. ft. per in. times in. per min. piston speed

Free air consumption per in. of stroke = Cu. ft. displaced x (press. + 14.7) – 14.7

| Piston Rod Dia. in inches | Bore Size N5 AN5 LAN5 | Piston Rod Area sq. in. | In-Stroke Pull In Pounds Force Deduct The Following Force Or Consumptions Corresponding To Rod Size From Out-Stroke Thrust Or Consumptions To Determine In-Stroke Pull Or Consumptions | | | | | | | | | | | | Consumption Per Inch Of Stroke in One Direction | | |
|---------------------------|-----------------------|-------------------------|---|---------|---------|---------|---------|----------|----------|----------|----------|---------|---------|---------|---|----------------------------------|--|
| | | | Pressures of Operating Medium – Air or Hydraulic | | | | | | | | | | | | Oil Gallons Displaced | Air Pressure Cubic Ft. Displaced | Free Air Cubic Ft. at 80 psi Displaced |
| 50 psi | 60 psi | 80 psi | 100 psi | 200 psi | 250 psi | 500 psi | 750 psi | 1000 psi | 1500 psi | 2000 psi | 3000 psi | | | | | | |
| 5/8 | 1 1/2 | .31 | 16 | 19 | 25 | 31 | 62 | 78 | 155 | 233 | 310 | 465 | 620 | 930 | .00138 | .00018 | .00116 |
| 1 | 2 & 2 1/2 | .79 | 40 | 47 | 63 | 79 | 158 | 198 | 395 | 593 | 790 | 1,185 | 1,580 | 2,370 | .00342 | .00046 | .00294 |
| 1 3/8 | 3 1/4 | 1.49 | 75 | 89 | 119 | 149 | 298 | 373 | 745 | 1,118 | 1,490 | 2,235 | 2,980 | 4,470 | .00645 | .00086 | .00555 |
| 1 3/4 | 4 | 2.41 | 121 | 145 | 193 | 241 | 482 | 603 | 1,205 | 1,808 | 2,410 | 3,615 | 4,820 | 7,230 | .01043 | .00139 | .00898 |
| 2 | 5 | 3.14 | 157 | 188 | 251 | 314 | 628 | 785 | 1,570 | 2,355 | 3,140 | 4,710 | 6,280 | 9,420 | .01359 | .00182 | .01170 |
| 2 1/2 | 6 | 4.91 | 246 | 295 | 393 | 491 | 982 | 1,228 | 2,455 | 3,683 | 4,910 | 7,365 | 9,820 | 14,730 | .02126 | .00284 | .01830 |
| 3 | 7 | 7.07 | 354 | 424 | 566 | 707 | 1,414 | 1,768 | 3,535 | 5,303 | 7,070 | 10,605 | 14,140 | 21,210 | .03061 | .00409 | .02635 |
| 3 1/2 | 8 | 9.62 | 481 | 577 | 770 | 962 | 1,924 | 2,405 | 4,810 | 7,215 | 9,620 | 14,430 | 19,240 | 28,860 | .04165 | .00557 | .03585 |
| 4 | - | 12.57 | 629 | 754 | 1,006 | 1,257 | 2,514 | 3,143 | 6,285 | 9,428 | 12,570 | 18,855 | 25,140 | 37,710 | .05442 | .00727 | .04685 |
| 4 1/2 | 10 | 15.90 | 795 | 954 | 1,272 | 1,590 | 3,180 | 3,975 | 7,950 | 11,925 | 15,900 | 23,850 | 31,800 | 47,700 | .06883 | .00920 | .05926 |
| 5 | - | 19.63 | 982 | 1,178 | 1,570 | 1,963 | 3,926 | 4,908 | 9,815 | 14,723 | 19,630 | 29,445 | 39,260 | 58,890 | .08498 | .01136 | .07316 |
| 5 1/2 | 12 | 23.76 | 1,188 | 1,426 | 1,901 | 2,376 | 4,752 | 5,940 | 11,880 | 17,820 | 23,760 | 35,640 | 47,520 | 71,280 | .10286 | .01375 | .08855 |
| 7 | 14 | 38.48 | 1,924 | 2,309 | 3,078 | 3,848 | 7,696 | 9,620 | 19,240 | 28,860 | 38,480 | 57,720 | 76,960 | 115,440 | .16658 | .02227 | .14341 |
| 8 | 16 | 50.27 | 2,514 | 3,016 | 4,022 | 5,027 | 10,054 | 12,568 | 25,135 | 37,703 | 50,270 | 75,405 | 100,540 | 150,810 | .21762 | .02909 | .18735 |
| 9 | 18 | 63.62 | 3,181 | 3,817 | 5,090 | 6,362 | 12,724 | 15,905 | 31,810 | 47,715 | 63,620 | 95,340 | 127,240 | 190,860 | .27541 | .03682 | .23710 |
| 10 | 20 | 78.54 | 3,927 | 4,712 | 6,283 | 7,854 | 15,708 | 19,638 | 39,270 | 58,905 | 78,540 | 117,810 | 157,080 | 235,620 | .34000 | .04545 | .29271 |
| 11 | 24 | 95.03 | 4,752 | 5,702 | 7,602 | 9,503 | 19,006 | 23,758 | 47,515 | 71,272 | 95,030 | 142,545 | 190,060 | 285,090 | .41138 | .05499 | .35413 |
| 14 | 30 | 153.94 | 7,697 | 9,236 | 12,315 | 15,394 | 30,788 | 38,485 | 76,970 | 115,455 | 153,940 | 230,910 | 307,880 | 461,820 | .66641 | .08908 | .57367 |

Note

Bore Dimensions Are 0.030" Larger Than NOMINAL.

Technical Data

Pressure-Thrust
Consumption-Flow Charts
(Continued)

PIPE SIZE CHART FOR HYDRAULIC CYLINDERS AND SYSTEMS

| Standard Weight Pipe | | | Oil Flow Gallons Per Minute And Friction Pressure Drop Pounds Per Square Inch Per Foot Length Of Pipe | | | | | | | | | | | |
|----------------------|------------------|--------------|---|----------------------|------------------------|----------------------|------------------------|----------------------|------------------------|----------------------|------------------------|----------------------|------------------------|----------------------|
| | | | Vel. = 5 Ft. Per Sec. | | Vel. = 10 Ft. Per Sec. | | Vel. = 15 Ft. Per Sec. | | Vel. = 20 Ft. Per Sec. | | Vel. = 25 Ft. Per Sec. | | Vel. = 30 Ft. Per Sec. | |
| Pipe Size | Inside Diameter* | Area Sq. In. | Gallons Per Minute | Pressure Drop In psi | Gallons Per Minute | Pressure Drop In psi | Gallons Per Minute | Pressure Drop In psi | Gallons Per Minute | Pressure Drop In psi | Gallons Per Minute | Pressure Drop In psi | Gallons Per Minute | Pressure Drop In psi |
| 1/2 | .622 | .304 | 4.7 | .157 | 9.4 | .585 | 14.1 | 1.215 | 18.6 | 2.065 | 23.5 | 3.130 | 28.2 | 4.34 |
| 3/4 | .824 | .533 | 8.3 | .117 | 16.6 | .370 | 24.9 | .710 | 33.2 | 1.520 | 41.5 | 2.300 | 49.8 | 3.17 |
| 1 | 1.049 | .864 | 13.5 | .090 | 26.9 | .323 | 40.4 | .673 | 53.8 | 1.555 | 67.3 | 1.725 | 80.8 | 2.44 |
| 1 1/4 | 1.380 | 1.495 | 23.3 | .064 | 46.5 | .231 | 69.8 | .488 | 93.0 | .755 | 116.3 | 1.240 | 139.6 | 1.74 |
| 1 1/2 | 1.610 | 2.036 | 31.7 | .054 | 63.4 | .181 | 95.1 | .404 | 126.8 | .691 | 158.5 | 1.042 | 190.2 | 1.48 |
| 2 | 2.067 | 3.355 | 52.3 | .047 | 104.5 | .169 | 156.8 | .360 | 209.0 | .609 | 261.3 | .927 | 313.6 | 1.11 |

The pressure drop shown in the above table is for ordinary wrought iron pipe. For smooth, new wrought iron pipes, multiply the values shown by .7; for very smooth, straight tubing, multiply the values shown by .54. Pressure drop is the same regardless of operating pressure. Avoid large pres-

sure drops in low pressure systems. Please note that oil flows through large pipes at a high velocity (up to 30 ft/sec) with small pressure loss. The pressure drop shown is for hydraulic oil with approximately 225 SSU at 100°F under average operating conditions. The values also apply to water. In order

to accommodate large pump volumes without severe pressure drops, all Eaton hydraulic cylinders are available with oversize ports with welded half pipe couplings or flange fitting.

| Standard Weight Pipe | | | Equivalent Length of Straight Pipe In Feet For Various Fitting | | | | | |
|----------------------|------------------|--------------|--|----------|------------|-------------|----------------------------|--------------|
| Pipe Size | Inside Diameter* | Area Sq. In. | Std. Elbow | Std. Tee | Gate Valve | Globe Valve | Cylinders & 2-3-Way Valves | 4-Way Valves |
| 1/2 | .622 | .304 | 1.5 | 3.3 | .35 | 17 | 6 to 30 | 12 to 60 |
| 3/4 | .824 | .533 | 2.2 | 4.5 | .47 | 22 | 10 to 50 | 20 to 100 |
| 1 | 1.049 | .864 | 2.7 | 5.8 | .60 | 28 | 13 to 65 | 25 to 125 |
| 1 1/4 | 1.380 | 1.495 | 3.7 | 7.7 | .81 | 37 | 15 to 75 | 30 to 150 |
| 1 1/2 | 1.610 | 2.036 | 4.4 | 9.2 | .92 | 44 | 20 to 100 | 40 to 200 |
| 2 | 2.067 | 3.355 | 5.5 | 12.0 | 1.20 | 57 | 25 to 125 | 50 to 250 |

* Inside diameter and areas shown are standard pipe. For tubing or extra heavy and double extra heavy pipe, use I.D. in table closest to your pipe or tubing I.D.

Technical Data

Cushion Formulas and Factors

Cushions are recommended when piston speed is in excess of 20-25 feet per minute. Cushions decelerate the piston and rod assembly at the end of the stroke, lessening the noise and shock

and increasing cylinder life. Heavy loads attached to the piston and rod assembly should be stopped by external means, such as shock absorbers, springs, decelerating valves, etc.

Use the information below, along with the examples on page 25 to determine if standard cushioning is sufficient for your application.

FORCE FACTOR CHART

Force Factors (a = v² x .001294)

| PISTON VELOCITY | PISTON VELOCITY |
|-----------------|-----------------|
| ips a | ips a |
| 1 .00129 | 26 .875 |
| 2 .00518 | 27 .944 |
| 3 .0117 | 28 1.02 |
| 4 .0208 | 29 1.09 |
| 5 .0324 | 30 1.16 |
| 6 .0466 | 31 1.24 |
| 7 .0635 | 32 1.33 |
| 8 .0829 | 33 1.41 |
| 9 .105 | 34 1.50 |
| 10 .129 | 35 1.59 |
| 11 .157 | 36 1.68 |
| 12 .186 | 37 1.77 |
| 13 .219 | 38 1.87 |
| 14 .254 | 39 1.97 |
| 15 .291 | 40 2.07 |
| 16 .332 | 41 2.18 |
| 17 .374 | 42 2.28 |
| 18 .420 | 43 2.39 |
| 19 .467 | 44 2.51 |
| 20 .518 | 45 2.62 |
| 21 .571 | 46 2.74 |
| 22 .627 | 47 2.86 |
| 23 .685 | 48 2.98 |
| 24 .746 | 49 3.11 |
| 25 .809 | 50 3.24 |

(continued)

FORCE FACTOR TERMINOLOGY

| TERM USED | EXPLANATION | UNITS |
|-----------|---|-----------------------------------|
| W | Weight of the load | pounds |
| Ab | Bore area | square inches |
| Ah | Ab less rod area | square inches |
| Acc | Ab less cap plunger cross-sectional area | square inches |
| Ahc | Ab less head plunger cross-sectional area | square inches |
| a | Force factor | — |
| s | Acceleration or deceleration distance | inches |
| u | Coefficient of friction of load's motion | Horizontal = .15; Vertical = 0 |
| v | Velocity | inches per second (ips) |
| Facc | Force needed to accelerate a weight | pounds |
| Fdec | Force needed to decelerate a weight | pounds |
| Ff | Friction force due to load motion | pounds |
| Fp | Driving pressure force | pounds |
| Ft | Total cushioning force | pounds |
| Pp | Pump pressure | pounds per square inch (psi) |
| Pc | Contained cushioning pressure | pounds per square inch (psi) |

GENERAL FORMULAS

| | |
|---|---|
| Horizontal motion | $F_{acc} \text{ or } F_{dec} = W \times a/s$ |
| Vertical motion, decelerating downward or accelerating upward | $F_{acc} \text{ or } F_{dec} = (W \times a/s) + W$ |
| Vertical motion, decelerating upward or accelerating downward | $F_{acc} \text{ or } F_{dec} = (W \times a/s) - W$ |
| Frictional force | $F_f = u \times W$ |
| Total cushioning force | $F_t = F_{acc} \text{ or } F_{dec} + F_p \pm F_f$ (+ F_f if load accelerating, — F_f if load decelerating) |
| Contained pressure | $P_c = F_t/A_{cc} \text{ or } F_t/A_{hc}$ |

Acceleration and Deceleration Forces

- The a force factors shown are used to determine the forces required to accelerate or decelerate a weight through a given distance, s (Refer to **Force Factor Chart**).
 - If the motion of the load is horizontal, use the general formula F_{acc} or $F_{dec} = W \times a/s$.
 - If the motion of the load is vertical and is being decelerated downward or accelerated upward, use the general formula F_{acc} or $F_{dec} = (W \times a/s) + W$.
 - If the motion of the load is vertical and is being decelerated upward or accelerated downward, use the general formula F_{acc} or $F_{dec} = (W \times a/s) - W$.
 - Friction due to load motion affects F_t . Add F_f to F_t if the load is accelerating. Subtract F_f from F_t if the load is decelerating.
 - Cylinder friction is negligible.
- Note
- The contained cushioning pressure must not exceed 5000 psi. If the standard cushion results in a too high pressure, then a longer cushion spud must be specified.

Technical Data

How to Calculate Your Cushion Requirements

STANDARD CUSHION INFORMATION N5 SERIES

HYDRAULIC EXAMPLES

Example A

Horizontal deceleration

N5 series cylinder, 3¹/₄" bore, 1³/₈" rod (standard), cushioning at cap.

A weight of 3000 lbs., moving at 25 ips, and driven by a pump pressure of 1000 psi should stopped in 1¹/₄". Assume the coefficient of friction to be .15.

- $F_f = u \times W$
 $= .15 \times 3000 \text{ lbs.}$
 $F_f = 450 \text{ lbs.}$
- $F_p = A_h \times P_p$
 $A_h = A_b - \text{rod area}$
 $= 8.45 \text{ sq. in.} - 1.49 \text{ sq. in.}$
 $A_h = 6.96 \text{ sq. in.}$
 $F_p = 6.96 \text{ sq. in.} \times 1000 \text{ psi}$
 $F_p = 6960 \text{ lbs.}$
- $F_{dec} = W \times a/s$
 $= 3000 \text{ lbs.} \times .809/1.25 \text{ in.}$
 $F_{dec} = 1942 \text{ lbs.}$
- $F_t = F_{dec} + F_p - F_f$
 $= 1942 + 6960 - 450$
 $F_t = 8452 \text{ lbs.}$
- $P_c = F_t/A_{cc}$
 $= 8452 \text{ lbs.}/7.85 \text{ sq. in.}$
 $P_c = 1077 \text{ psi}$

This figure does not exceed the pressure capability of the cylinder, therefore, the standard cushion is acceptable.

Example B

Vertical deceleration

N5 series cylinder, 6" bore, 2¹/₂" rod (standard), cushioning at head.

The cylinder is mounted vertical rod down, with a 2000 lb. load attached to the rod end. Pump pressure is 750 psi, the load is moving at 40 ips, and must be stopped in 1³/₈". There is no load friction.

- $F_p = P_p \times A_b$
 $= 750 \text{ psi} \times 28.56 \text{ sq. in.}$
 $F_p = 21,420 \text{ lbs.}$
- $F_{dec} = (W \times a/s) + W$
 $= (2000 \text{ lbs.} \times 2.07/1.375) + 2000 \text{ lbs.}$
 $F_{dec} = 5011 \text{ lbs.}$
- $F_t = F_p + F_{dec}$
 $= 21,420 \text{ lbs.} + 5011 \text{ lbs.}$
 $F_t = 26,431 \text{ lbs.}$
- $P_c = F_t/A_{hc}$
 $= 26,431 \text{ lbs.}/22.07 \text{ sq. in.}$
 $P_c = 1198 \text{ psi}$

This does not exceed the pressure capability of the cylinder, therefore, the standard cushion is acceptable.

Note

If your calculations show you need a longer cushion than standard, longer cushions are available in 1/4 inch increments.

| Bore Size | Rod Dia. | Cushion Length (in.) | | Effective Cushion Area (in. ²) | |
|-------------------------------|-------------------------------|--------------------------------|--------------------------------|--|------------------------|
| | | Head | Cap | Head (A _{hc}) | Cap (A _{cc}) |
| 1 ¹ / ₂ | 5/8 | 1 ¹ / ₈ | 1 ³ / ₁₆ | 1.24 | 1.70 |
| | 1 | 1 ¹ / ₈ | 1 ³ / ₁₆ | .73 | 1.70 |
| 2 | 1 | 1 ¹ / ₈ | 1 ¹ / ₈ | 2.13 | 2.91 |
| | 1 ³ / ₈ | 1 ¹ / ₈ | 1 ¹ / ₈ | 1.17 | 2.90 |
| 2 ¹ / ₂ | 1 | 1 ¹ / ₈ | 1 ¹ / ₈ | 3.92 | 4.77 |
| | 1 ³ / ₈ | 1 ¹ / ₈ | 1 ¹ / ₈ | 2.96 | 4.77 |
| 3 ¹ / ₄ | 1 ³ / ₄ | 1 ¹ / ₈ | 1 ¹ / ₈ | 1.89 | 4.77 |
| | 1 ³ / ₈ | 1 ³ / ₈ | 1 ¹ / ₄ | 6.38 | 7.85 |
| | 1 ³ / ₄ | 1 ³ / ₈ | 1 ¹ / ₄ | 5.31 | 7.85 |
| 4 | 2 | 1 ³ / ₈ | 1 ¹ / ₄ | 4.02 | 7.85 |
| | 1 ³ / ₄ | 1 ³ / ₈ | 1 ¹ / ₄ | 9.62 | 12.16 |
| | 2 | 1 ³ / ₈ | 1 ¹ / ₄ | 8.33 | 12.16 |
| 5 | 2 ¹ / ₂ | 1 ³ / ₈ | 1 ¹ / ₄ | 6.27 | 12.16 |
| | 2 | 1 ³ / ₈ | 1 ¹ / ₄ | 15.44 | 18.64 |
| | 2 ¹ / ₂ | 1 ³ / ₈ | 1 ¹ / ₄ | 13.38 | 18.64 |
| 6 | 3 | 1 ⁵ / ₁₆ | 1 ¹ / ₄ | 10.93 | 18.64 |
| | 3 ¹ / ₂ | 1 ⁵ / ₁₆ | 1 ¹ / ₄ | 8.08 | 18.64 |
| | 2 ¹ / ₂ | 1 ³ / ₈ | 1 ¹ / ₂ | 22.07 | 26.16 |
| 7 | 3 | 1 ⁵ / ₁₆ | 1 ¹ / ₂ | 19.62 | 26.16 |
| | 3 ¹ / ₂ | 1 ⁵ / ₁₆ | 1 ¹ / ₂ | 16.77 | 26.16 |
| | 4 | 1 ¹ / ₂ | 1 ¹ / ₂ | 15.20 | 26.16 |
| 8 | 3 | 2 | 2 | 29.88 | 36.42 |
| | 3 ¹ / ₂ | 2 | 2 | 27.03 | 36.42 |
| | 4 | 2 | 2 | 25.46 | 36.42 |
| | 4 ¹ / ₂ | 2 | 2 | 19.29 | 36.42 |
| | 5 | 2 | 2 | 17.70 | 36.42 |
| 10 | 3 ¹ / ₂ | 2 | 2 | 38.85 | 48.24 |
| | 4 | 2 | 2 | 37.28 | 48.24 |
| | 4 ¹ / ₂ | 2 | 2 | 31.11 | 48.24 |
| | 5 | 2 | 2 | 29.52 | 48.24 |
| | 5 ¹ / ₂ | 2 | 2 | 29.52 | 48.24 |
| 12 | 4 ¹ / ₂ | 2 | 2 | 59.48 | 74.12 |
| | 5 | 2 | 2 | 57.89 | 74.12 |
| | 5 ¹ / ₂ | 2 | 2 | 57.89 | 74.12 |
| 14 | 7 | 2 | 2 | 31.91 | 74.12 |
| | 5 ¹ / ₂ | 2 | 2 | 92.54 | 108.77 |
| | 7 | 2 | 2 | 66.56 | 108.77 |
| 16 | 8 | 2 | 2 | 53.61 | 108.77 |
| | 7 | 2 | 2 | 107.50 | 143.36 |
| | 8 | 2 | 2 | 94.55 | 143.36 |
| 18 | 9 | 2 | 2 | 80.04 | 143.36 |
| | 10 | 2 | 2 | 63.95 | 143.36 |
| | 8 | 2 | 2 | 141.77 | 192.26 |
| 20 | 9 | 2 | 2 | 127.26 | 192.26 |
| | 10 | 2 | 2 | 111.17 | 192.26 |
| | 9 | 2 | 2 | 180.76 | 245.76 |
| 24 | 10 | 2 | 2 | 164.67 | 245.76 |
| | 10 | 2 | 2 | 224.45 | 304.12 |
| 30 | 11 | 2 | 2 | 325.99 | 439.82 |
| | 14 | 2 | 2 | 512.03 | 687.22 |

Port Data

Ports

Standard ports for N5 are SAE straight thread. AN5 and LAN5 standard ports are NPTF.

Optional and Oversize Ports

The chart to the right lists port sizes. Larger welded half-pipe coupling ports are available in some sizes; please contact Eaton. For oversize ports where short restrictions in dash pot areas cannot be allowed, specify "full flow porting."

Port, Cushion Adjustment, Ball Check Locations

Standard port locations are at #1, with optional locations at #2, 3, 4 or 5 furnished when specified, except where **H**, **U** or **W** mounts interfere at #2 and #4. Ports at #3 in **B** and the cap end of **E** mountings need special construction. Note possible piping interference with mounting screws in **A** cylinders ported at Pos. 2 and 4. Mounting holes are counter-bored to allow access to them with piping in place.

In the end view shown, standard position of cushion adjustment is above port location #2 in location C3; ball check above port location #4 at C8 when ports are at position #1. On **H**, the head on **G**, **U** and the cap on **P**, **W** cushion adjustments are on the right side of port location #3 at C5, and checks are on the left side at C6.

Locations 1 through 4 indicate possible port positions. Number 1 is standard. Optional location #5 is available on cap end centerline.

Locations C1 through C8 indicate possible cushion adjustment positions. When ports are at position #1, C3 is standard needle location.

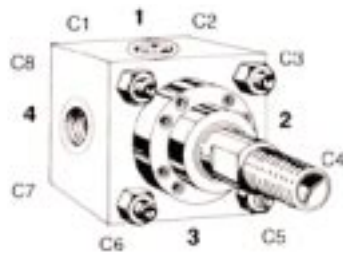

* Fitting hex may interfere with mountings **S**, **R** and **P**. Consult factory for additional information.

** Flanges may overhang head and caps. Consult factory for additional information.

*** Manifold dimension is for flow passage diameter.

| Cylinder Bore Dia. (inches) | Rod Diameter (inches) | SAE* | | | | NPTF | | | ** 4-Bolt SAE | Manifold *** |
|-----------------------------|-----------------------|------|----------|-----|--------|----------|--------|--------|---------------|--------------|
| | | Std. | Oversize | | Std. | Oversize | | | | |
| | | | Head | Cap | | Head | Cap | | | |
| 1 1/2" | 5/8" | #10 | N/A | N/A | 1/2" | 3/4" | 3/4" | N/A | 9/16" | |
| | 1" | #10 | N/A | N/A | 1/2" | N/A | 3/4" | N/A | 9/16" | |
| 2" | 1" | #10 | N/A | N/A | 1/2" | 3/4" | 3/4" | N/A | 9/16" | |
| | 1 3/8" | #10 | N/A | N/A | 1/2" | N/A | 3/4" | N/A | 9/16" | |
| 2 1/2" | 1" | #10 | N/A | N/A | 1/2" | 3/4" | 3/4" | 1/2" | 9/16" | |
| | 1 3/8" | #10 | N/A | N/A | 1/2" | 3/4" | 3/4" | 1/2" | 9/16" | |
| | 1 3/4" | #10 | N/A | N/A | 1/2" | N/A | 3/4" | N/A | 9/16" | |
| 3 1/4" | 1 3/8" | #12 | #16 | #16 | 3/4" | 1" | 1" | 3/4" | 3/4" | |
| | 1 3/4" | #12 | #16 | #16 | 3/4" | 1" | 1" | 3/4" | 3/4" | |
| | 2" | #12 | #16 | #16 | 3/4" | 1" | 1" | 3/4" | 3/4" | |
| 4" | 1 3/4" | #12 | #16 | #16 | 3/4" | 1" | 1" | 3/4" | 3/4" | |
| | 2" | #12 | #16 | #16 | 3/4" | 1" | 1" | 3/4" | 3/4" | |
| | 2 1/2" | #12 | #16 | #16 | 3/4" | 1" | 1" | 3/4" | 3/4" | |
| 5" | 2" | #12 | #16 | #16 | 3/4" | 1" | 1" | 3/4" | 3/4" | |
| | 2 1/2" | #12 | #16 | #16 | 3/4" | 1" | 1" | 3/4" | 3/4" | |
| | 3" | #12 | #16 | #16 | 3/4" | 1" | 1" | 3/4" | 3/4" | |
| 6" | 3 1/2" | #12 | #16 | #16 | 3/4" | 1" | 1" | 3/4" | 3/4" | |
| | 2 1/2" | #16 | N/A | #20 | 1" | 1 1/4" | 1 1/4" | 1" | 1" | |
| | 3" | #16 | N/A | #20 | 1" | 1 1/4" | 1 1/4" | 1" | 1" | |
| 7" | 3 1/2" | #16 | N/A | #20 | 1" | 1 1/4" | 1 1/4" | 1" | 1" | |
| | 3" | #20 | #24 | #24 | 1 1/4" | 1 1/2" | 1 1/2" | 1 1/4" | 1 3/8" | |
| | 4" | #20 | #24 | #24 | 1 1/4" | 1 1/2" | 1 1/2" | 1 1/4" | 1 3/8" | |
| 8" | 4 1/2" | #20 | #24 | #24 | 1 1/4" | 1 1/2" | 1 1/2" | 1 1/4" | 1 3/8" | |
| | 5" | #20 | #24 | #24 | 1 1/4" | 1 1/2" | 1 1/2" | 1 1/4" | 1 3/8" | |
| | 3 1/2" | #24 | N/A | N/A | 1 1/2" | 2" | 2" | 1 1/2" | 1 5/8" | |
| | 4" | #24 | N/A | N/A | 1 1/2" | 2" | 2" | 1 1/2" | 1 5/8" | |
| | 4 1/2" | #24 | N/A | N/A | 1 1/2" | 2" | 2" | 1 1/2" | 1 5/8" | |
| 10" | 5 1/2" | #24 | N/A | N/A | 1 1/2" | 2" | 2" | 1 1/2" | 1 5/8" | |
| | 4 1/2" | #32 | N/A | N/A | 2" | 2 1/2" | 2 1/2" | 2" | N/A | |
| | 5" | #32 | N/A | N/A | 2" | 2 1/2" | 2 1/2" | 2" | N/A | |
| | 7" | #32 | N/A | N/A | 2" | 2 1/2" | 2 1/2" | 2" | N/A | |
| 12" | 5 1/2" | #32 | N/A | N/A | 2 1/2" | 3" | 3" | 2 1/2" | N/A | |
| | 7" | #32 | N/A | N/A | 2 1/2" | 3" | 3" | 2 1/2" | N/A | |
| | 8" | #32 | N/A | N/A | 2 1/2" | 3" | 3" | 2 1/2" | N/A | |
| 14" | 7" | #32 | N/A | N/A | 2 1/2" | 3" | 3" | 2 1/2" | N/A | |
| | 8" | #32 | N/A | N/A | 2 1/2" | 3" | 3" | 2 1/2" | N/A | |
| | 9" | #32 | N/A | N/A | 2 1/2" | 3" | 3" | 2 1/2" | N/A | |
| | 10" | #32 | N/A | N/A | 2 1/2" | 3" | 3" | 2 1/2" | N/A | |
| 16" | 8" | #32 | N/A | N/A | 3" | 3 1/2" | 3 1/2" | 2 1/2" | N/A | |
| | 9" | #32 | N/A | N/A | 3" | 3 1/2" | 3 1/2" | 2 1/2" | N/A | |
| | 10" | #32 | N/A | N/A | 3" | 3 1/2" | 3 1/2" | 2 1/2" | N/A | |
| 18" | 9" | #32 | N/A | N/A | 3" | 3 1/2" | 3 1/2" | 3" | N/A | |
| | 10" | #32 | N/A | N/A | 3" | 3 1/2" | 3 1/2" | 3" | N/A | |
| 20" | 10" | #32 | N/A | N/A | 3" | 3 1/2" | 3 1/2" | 3" | N/A | |
| 24" | 11" | #32 | N/A | N/A | 3" | 3 1/2" | 3 1/2" | 4" | N/A | |
| 30" | 14" | #32 | N/A | N/A | 3" | 3 1/2" | 3 1/2" | 5" | N/A | |

N5 Series Hydraulic Pressure Ratings

| Cylinder Bore (inches) | Piston Rod Diameters (inches) | | | Pressure Ratings (psi) | |
|------------------------|-------------------------------|-----------------|-------|------------------------|-----------|
| | Standard | Oversize | 2:1 | 4:1 Tensile | 4:1 Yield |
| 1 1/2 | 5/8 | – | 1 | 3750 | 3008 |
| 2 | 1 | – | 1 3/8 | 2900 | 2335 |
| 2 1/2 | 1 | 1 3/8 | 1 3/4 | 3150 | 2531 |
| 3 1/4 | 1 3/8 | 1 3/4 | 2 | 3050 | 2477 |
| 4 | 1 3/4 | 2 | 2 1/2 | 2400 | 2214 |
| 5 | 2 | 2 1/2, 3 | 3 1/2 | 3100 | 2836 |
| 6 | 2 1/2 | 3, 3 1/2 | 4 | 2800 | 2406 |
| 7 | 3 | 3 1/2, 4, 4 1/2 | 5 | 2850 | 2336 |
| 8 | 3 1/2 | 4, 4 1/2, 5 | 5 1/2 | 2375 | 1975 |
| 10 | 4 1/2 | 5, 5 1/2 | 7 | 2900 | 2499 |
| 12 | 5 1/2 | 7 | 8 | 2550 | 2069 |
| 14 | 7 | 8, 9 | 10 | 2600 | 1796 |
| 16 | 8 | 9, 10 | – | 2150 | 1864 |
| 18 | 9 | 10 | – | 2550 | 1919 |
| 20 | 10 | – | – | 2100 | 1822 |
| 24 | 11 | – | – | 2750 | 1921 |
| 30 | 14 | – | – | 2750 | 1835 |

N5 Series cylinders comply with NFPA specifications and ANSI B93.15-1981 mounting dimensions are standard.

Rod Cartridge Retainers Simplify Cartridge Removal

Cylinders with the following bore and rod combinations use circular retainers which permit removal of rod cartridge without disassembling the cylinder:

- 2 1/2" bore with 1" rod
- 3 1/4" bore with 1 3/8" rod
- 4" bore and larger with all rod diameters

Refer to Engineering File number 188 for alternate removable cartridge constructions.

Cylinders use above retainer construction on the following bore and rod combinations:

- 1 1/2" bore with 5/8" and 1" rods
- 2 1/2" bore with 1 3/8" and 1 3/4" rods
- 2" bore with 1" and 1 3/8" rods
- 3 1/4" bore with 1 3/4" and 2" rods

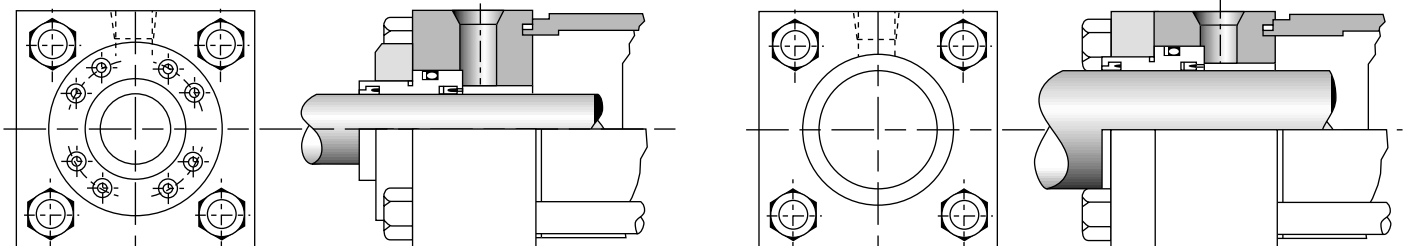

Typical Mounting Accessories

For Standard Rod Diameters
Style #2

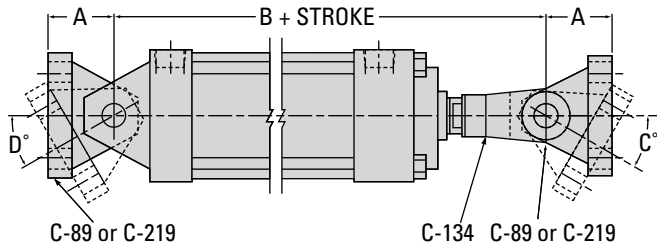

N5, AN5 and LN5 Cylinder

| Bore | A | B | Eye Bracket | | Female Clevis | Pivot Pin | C° | D° |
|-------|---------|---------|-------------|------------|---------------|-----------|-----|-----|
| | | | Standard | Swivel | | | | |
| 1 1/2 | 1 1/8 | 7 7/8 | C-8903 | C-219-3-1 | C-134-05 | C-9003-3 | 90° | 60° |
| 2 | 1 7/8 | 9 5/8 | C-8904 | C-219-3-2 | C-134-08 | C-9004-3 | 90° | 65° |
| 2 1/2 | 1 7/8 | 9 3/4 | C-8904 | C-219-3-2 | C-134-08 | C-9004-3 | 90° | 65° |
| 3 1/4 | 2 3/8 | 11 3/4 | C-89065X | C-219-3-3X | C-134-11 | C-9065-3 | 80° | 65° |
| 4 | 3 | 13 7/8 | C-8908 | C-219-3-4 | C-134-14 | C-9008-3 | 90° | 70° |
| 5 | 3 3/8 | 15 | C-8910X | C-219-3-5X | C-134-16 | C-9010-3 | 75° | 65° |
| 6 | 4 | 17 5/8 | C-8912X | C-219-3-6X | C-134-20 | C-9012-3 | 75° | 65° |
| 7 | 4 | 20 1/4 | C-8914 | | C-134-24 | C-9014-3 | 70° | 65° |
| 8 | 4 1/4 | 21 3/4 | C-8916 | | C-134-28 | C-9016-3 | 70° | 65° |
| 10 | 5 11/16 | 27 9/16 | C-8920 | | C-134-36 | C-9020-3 | 70° | 60° |
| 12 | 6 7/16 | 32 3/16 | C-8924 | | C-134-44 | C-9024-3 | 65° | 60° |

For mounting dimensions over 12" bore, consult Eaton.

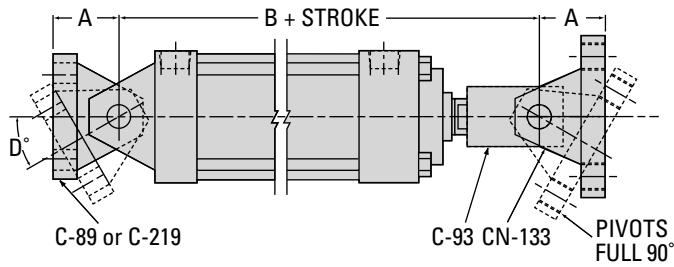

N5, AN5 and LN5 Cylinder

| Bore | C | B | Eye Bracket | | Clevis Bracket | Pivot Pin | Female Eye | D° |
|-------|---------|----------|-------------|------------|----------------|-----------|------------|-----|
| | | | Standard | Swivel | | | | |
| 1 1/2 | 1 1/8 | 7 7/8 | C-8903 | C-219-3-1 | CN-133-03 | C-9003-3 | C-9303 | 60° |
| 2 | 1 7/8 | 9 5/16 | C-8904 | C-219-3-2 | CN-133-04 | C-9004-3 | C-9304 | 65° |
| 2 1/2 | 1 7/8 | 9 7/16 | C-8904 | C-219-3-2 | CN-133-05 | C-9004-3 | C-9304 | 65° |
| 3 1/4 | 2 3/8 | 11 7/16 | C-89065X | C-219-3-3X | CN-133-065 | C-9065-3 | C-93065 | 65° |
| 4 | 3 | 13 3/16 | C-8908 | C-219-3-4 | CN-133-08 | C-9008-3 | C-9308 | 70° |
| 5 | 3 3/8 | 14 1/2 | C-8910X | C-219-3-5X | CN-133-10 | C-9010-3 | C-9310 | 65° |
| 6 | 4 | 17 1/8 | C-8912X | C-219-3-6X | CN-133-12 | C-9012-3 | C-9312 | 65° |
| 7 | 4 | 19 9/16 | C-8914 | | CN-133-14 | C-9014-3 | C-9314 | 65° |
| 8 | 4 1/4 | 21 1/8 | C-8916 | | CN-133-16 | C-9016-3 | C-9316 | 65° |
| 10 | 5 11/16 | 26 11/16 | C-8920 | | CN-133-20 | C-9020-3 | C-9320 | 60° |
| 12 | 6 7/16 | 31 5/16 | C-8924 | | CN-133-24 | C-9024-3 | C-9324 | 60° |

For mounting dimensions over 12" bore, consult Eaton.

Cylinder Mounting Accessories

Pivot Pin

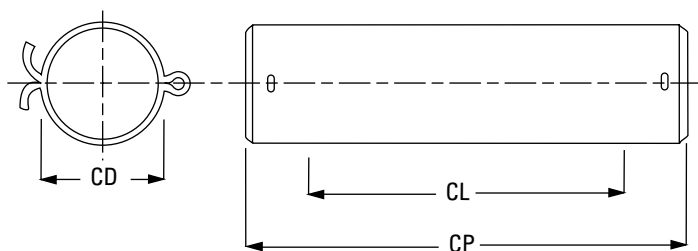

1. Pivot pins are furnished with clevis mounted cylinders.
2. Pivot pins must be ordered as a separate item if used with female eye, female clevis, standard eye bracket and clevis bracket. They are included only with swivel eye bracket.
3. $CL = (2 \times CW) + CB$

| Part No. | CD | CL | CP |
|-----------|-------|-------|--------|
| C-9003-3 | 1/2 | 1 3/4 | 2 3/8 |
| C-9004-3 | 3/4 | 2 1/2 | 3 1/8 |
| C-90065-3 | 1 | 3 | 3 3/4 |
| C-9008-3 | 1 3/8 | 4 | 4 3/4 |
| C-9010-3 | 1 3/4 | 5 | 6 1/32 |
| C-9012-3 | 2 | 5 | 6 1/32 |
| C-9014-3 | 2 1/2 | 6 | 7 1/32 |
| C-9016-3 | 3 | 6 | 7 1/8 |
| C-9020-3 | 3 1/2 | 8 | 9 5/8 |
| C-9024-3 | 4 | 9 | 10 5/8 |

Female Eye

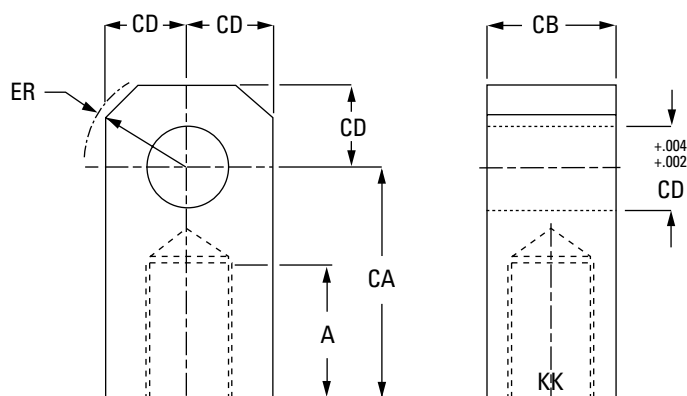

| Part No. | A | CA | CB | CD | ER | KK |
|----------|-------|---------|-------|-------|---------|----------|
| C-9302 | 3/4 | 1 1/2 | 7/16 | 7/16 | 19/32 | 5/16-24 |
| C-9303 | 3/4 | 1 1/2 | 3/4 | 1/2 | 5/8 | 7/16-20 |
| C-9304 | 1 1/8 | 2 1/16 | 1 1/4 | 3/4 | 7/8 | 3/4-16 |
| C-93065 | 1 5/8 | 2 13/16 | 1 1/2 | 1 | 1 3/16 | 1-14 |
| C-9308 | 2 | 3 7/16 | 2 | 1 3/8 | 1 9/16 | 1 1/4-12 |
| C-9310 | 2 1/4 | 4 | 2 1/2 | 1 3/4 | 2 | 1 1/2-12 |
| C-9312 | 3 | 5 | 2 1/2 | 2 | 2 1/4 | 1 7/8-12 |
| C-9314 | 3 1/2 | 5 13/16 | 3 | 2 1/2 | 2 13/16 | 2 1/4-12 |
| C-9316 | 3 1/2 | 6 1/8 | 3 | 3 | 3 1/4 | 2 1/2-12 |
| C-9320 | 4 1/2 | 7 5/8 | 4 | 3 1/2 | 3 7/8 | 3 1/4-12 |
| C-9324 | 5 1/2 | 9 1/8 | 4 1/2 | 4 | 4 7/16 | 4-12 |

Cylinder Mounting Accessories

(continued)

Spherical Rod Eye

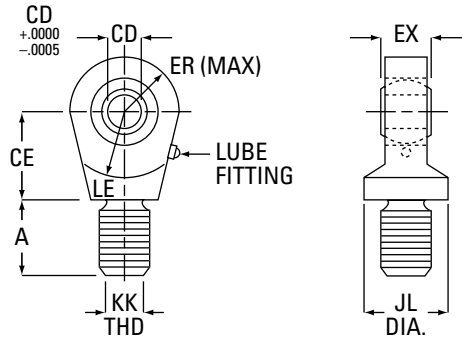

| Part No. | A | CD +.0000 -.0005 | CE | EX | ER | JL | KK | LE | Load Capacity (lbs.) |
|----------|-------|------------------------|-------|---------|---------|--------|----------|--------|----------------------|
| CS-9303 | 11/16 | 1/2 | 7/8 | 7/16 | 7/8 | 7/8 | 7/16-20 | 3/4 | 2,600 |
| CS-9304 | 1 | 3/4 | 1 1/4 | 21/32 | 1 1/4 | 1 5/16 | 3/4-16 | 1 1/16 | 9,400 |
| CS-93065 | 1 1/2 | 1 | 1 7/8 | 7/8 | 1 3/8 | 1 1/2 | 1-14 | 1 7/16 | 16,800 |
| CS-9308 | 2 | 1 3/8 | 2 1/8 | 1 3/16 | 11 3/16 | 2 | 1 1/4-12 | 1 7/8 | 28,600 |
| CS-9310 | 2 1/8 | 1 3/4 | 2 1/2 | 11 7/32 | 2 3/16 | 2 1/4 | 1 1/2-12 | 2 1/8 | 43,000 |
| CS-9312 | 2 7/8 | 2 | 2 3/4 | 1 3/4 | 2 5/8 | 2 3/4 | 1 7/8-12 | 2 1/2 | 70,000 |

Female Clevis

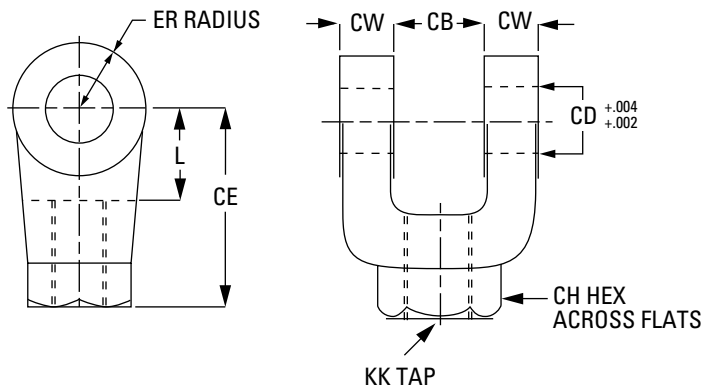

| Part No. | CB | CD | CE | CH | CW | ER | KK | L |
|----------|-------|-------|-------|---------|-------|-------|----------|-------|
| C-134-05 | 3/4 | 1/2 | 1 1/2 | 7/8 | 1/2 | 1/2 | 7/16-20 | 3/4 |
| C-134-08 | 1 1/4 | 3/4 | 2 3/8 | 1 3/8 | 5/8 | 3/4 | 3/4-16 | 1 1/4 |
| C-134-11 | 1 1/2 | 1 | 3 1/8 | 1 5/8 | 3/4 | 1 | 1-14 | 1 1/2 |
| C-134-14 | 2 | 1 3/8 | 4 1/8 | 2 | 1 | 1 3/8 | 1 1/4-12 | 2 1/8 |
| C-134-16 | 2 1/2 | 1 3/4 | 4 1/2 | 2 3/8 | 1 1/4 | 1 3/4 | 1 1/2-12 | 2 1/4 |
| C-134-20 | 2 1/2 | 2 | 5 1/2 | 2 15/16 | 1 1/4 | 2 | 1 7/8-12 | 2 1/2 |
| C-134-24 | 3 | 2 1/2 | 6 1/2 | 3 1/2 | 1 1/2 | 2 1/2 | 2 1/4-12 | 3 |
| C-134-28 | 3 | 3 | 6 3/4 | 3 7/8 | 1 1/2 | 2 3/4 | 2 1/2-12 | 3 1/4 |
| C-134-36 | 4 | 3 1/2 | 8 1/2 | 5 | 2 | 3 1/2 | 3 1/4-12 | 4 |
| C-134-44 | 4 1/2 | 4 | 10 | 6 1/8 | 2 1/4 | 4 | 4-12 | 4 1/2 |

Mounting Accessories

Swivel Eye Bracket Standard Eye Bracket

(Includes spacers to allow swivel action up to 7° and to make dimensions interchangeable with standard eye bracket.)

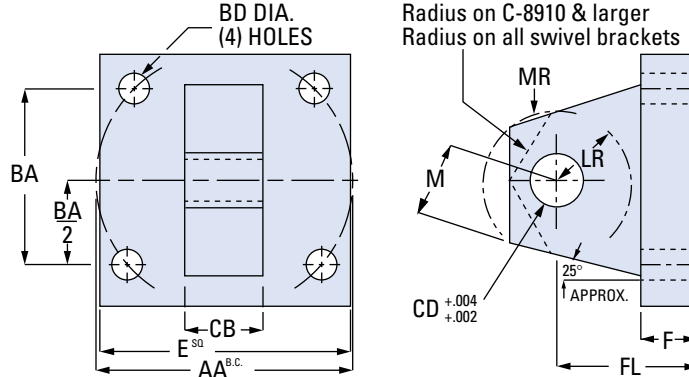

* To assure precision fit-up, pivot pins machined to special tolerances are furnished with all swivel eye brackets, unless otherwise specified.

**Dimensions F and FL reflect revised NFPA standards. Part numbers with suffix letter X are affected.

| Part Number | | Dimensions | | | | | | | | | | Standard Bracket | | Swivel Bracket | | Swivel Bracket Recommended Static Load Limit in lbs. |
|-------------|------------|------------|---------|---------|-------|-------|--------|---------|---------|-------|-------|------------------|--------|----------------|---------|--|
| Standard | Swivel* | AA | BA | BD | CB | CD | E | F** | FL** | LR | M | MR | M | MR | | |
| Part No. | Part No. | | | | | | | | | | | | | | | |
| C-8903 | C-219-3-1 | 2.3 | 15/8 | 13/32 | 3/4 | 1/2 | 2 1/2 | 3/8 | 1 1/8 | 1/2 | 1/2 | 9/16 | 11/16 | 11/16 | 8,100 | |
| C-8904 | C-219-3-2 | 3.6 | 29/16 | 17/32 | 1 1/4 | 3/4 | 3 1/2 | 5/8 | 1 7/8 | 1 | 3/4 | 1 1/16 | 1 3/16 | 1 3/16 | 18,800 | |
| C-89065X | C-219-3-3X | 4.6 | 3 1/4 | 2 1/32 | 1 1/2 | 1 | 4 1/2 | 7/8 | 2 3/8 | 1 | 1 | 1 1/8 | 1 3/8 | 1 3/8 | 33,300 | |
| C-8908 | C-219-3-4 | 5.4 | 3 13/16 | 2 1/32 | 2 | 1 3/8 | 5 | 7/8 | 3 | 1 1/8 | 1 3/8 | 1 3/4 | 2 | 2 | 59,800 | |
| C-8910X | C-219-3-5X | 7.0 | 4 15/16 | 2 9/32 | 2 1/2 | 1 3/4 | 6 1/2 | 1 1/8 | 3 3/8 | 1 3/4 | 1 3/4 | 1 7/8 | 2 1/8 | 2 1/8 | 102,000 | |
| C-8912X | C-219-3-6X | 8.1 | 5 3/4 | 1 1/32 | 2 1/2 | 2 | 7 1/2 | 1 1/2 | 4 | 2 | 2 | 2 1/8 | 2 3/8 | 2 3/8 | 132,000 | |
| C-8914X | | 9.3 | 6 19/32 | 1 5/32 | 3 | 2 1/2 | 8 1/2 | 1 3/4 | 4 3/4 | 2 1/2 | 2 1/2 | 2 1/2 | | | | |
| C-8916X | | 10.6 | 7 1/2 | 1 9/32 | 3 | 3 | 9 1/2 | 2 | 5 1/4 | 2 3/4 | 2 3/4 | 2 3/4 | | | | |
| C-8920 | | 13.6 | 9 5/8 | 1 25/32 | 4 | 3 1/2 | 12 5/8 | 1 11/16 | 5 11/16 | 3 1/2 | 3 1/2 | 3 1/2 | | | | |
| C-8924 | | 16.2 | 11 1/2 | 2 1/32 | 4 1/2 | 4 | 14 7/8 | 1 15/16 | 6 7/16 | 3 7/8 | 4 | 4 | | | | |

Clevis Bracket

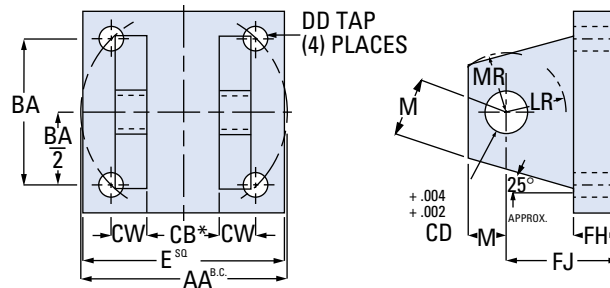

| Part No. | AA | BA | CB | CD | CW | DD | E | FH | FJ | LR | M | MR |
|------------|------|---------|---------|-------|-------|----------|--------|---------|---------|--------|-------|--------|
| CN-133-03 | 2.3 | 1 5/8 | 25/32 | 1/2 | 1/2 | 3/8-24 | 2 1/2 | 3/8 | 1 1/8 | 1/2 | 1/2 | 9/16 |
| CN-133-04 | 2.9 | 2 1/16 | 19/32 | 3/4 | 5/8 | 1/2-20 | 3 | 5/8 | 1 7/8 | 1 | 3/4 | 1 1/16 |
| CN-133-05 | 3.6 | 2 9/16 | 19/32 | 3/4 | 5/8 | 1/2-20 | 3 1/2 | 5/8 | 1 7/8 | 1 1/16 | 3/4 | 1 1/16 |
| CN-133-065 | 4.6 | 3 1/4 | 1 17/32 | 1 | 3/4 | 5/8-18 | 4 1/2 | 3/4 | 2 1/4 | 1 1/4 | 1 | 1 1/8 |
| CN-133-08 | 5.4 | 3 13/16 | 2 1/32 | 1 3/8 | 1 | 5/8-18 | 5 | 7/8 | 3 | 1 7/8 | 1 3/8 | 1 3/4 |
| CN-133-10 | 7.0 | 4 15/16 | 2 17/32 | 1 3/4 | 1 1/4 | 7/8-14 | 6 1/2 | 7/8 | 3 1/8 | 2 | 1 3/4 | 1 7/8 |
| CN-133-12 | 8.1 | 5 3/4 | 2 17/32 | 2 | 1 1/4 | 1-14 | 7 1/2 | 1 | 3 1/2 | 2 1/8 | 2 | 2 1/8 |
| CN-133-14 | 9.3 | 6 19/32 | 3 1/32 | 2 1/2 | 1 1/2 | 1 1/8-12 | 8 1/2 | 1 | 4 | 2 5/8 | 2 1/2 | 2 1/2 |
| CN-133-16 | 10.6 | 7 1/2 | 3 1/32 | 3 | 1 1/2 | 1 1/4-12 | 9 1/2 | 1 | 4 1/4 | 2 7/8 | 2 3/4 | 2 3/4 |
| CN-133-20 | 13.6 | 9 5/8 | 4 1/16 | 3 1/2 | 2 | 1 3/4-12 | 12 5/8 | 1 11/16 | 5 11/16 | 3 5/8 | 3 1/2 | 3 1/2 |
| CN-133-24 | 16.2 | 11 1/2 | 4 9/16 | 4 | 2 1/4 | 2-12 | 14 7/8 | 1 15/16 | 6 7/16 | 4 | 4 | 4 |

Self-Aligning Coupler

Lateral movement (on push only) and radial movement provide precision alignment between cylinder and machine. Couplers preset with proper clearances and completely lubricated at factory before shipping.

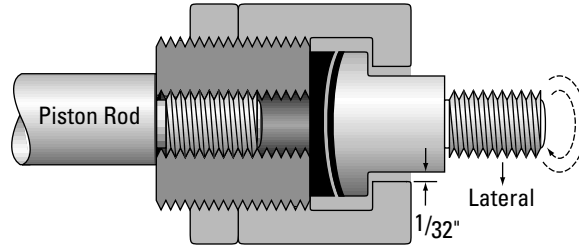

Self-aligning Coupler

Note

When ordering oversize and 2:1 rod cylinders, specify modification to suit standard rod diameter's coupler.

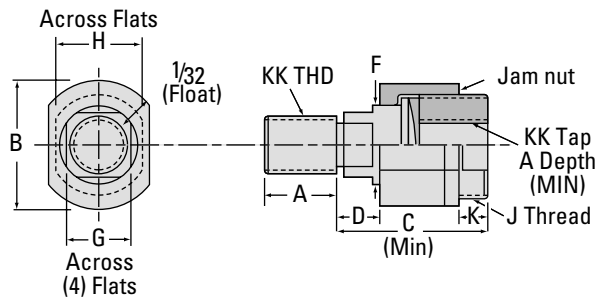

Self-aligning Rod End Coupler

| Part No. | Rod Dia. | A | B | C | D | F | G | H | J | K | KK | Max. Pull At Yield |
|----------|----------|-------|---------|---------|-----|---------|--------|-------|----------|---------|----------|--------------------|
| AC-2-05 | 5/8 | 3/4 | 1 1/4 | 2 | 1/2 | 5/8 | 1/2 | 13/16 | 1.14 | 5/16 | 7/16-20 | 8,320 |
| AC-2-08 | 1 | 1 1/8 | 1 11/16 | 2 5/16 | 1/2 | 31/32 | 13/16 | 1 1/8 | 13/8-12 | 1/2 | 3/4-16 | 35,000 |
| AC-2-11 | 1 3/8 | 1 5/8 | 2 3/8 | 2 29/32 | 1/2 | 1 11/32 | 1 5/32 | 1 5/8 | 1 7/8-12 | 1 1/16 | 1-14 | 64,500 |
| AC-2-14 | 1 3/4 | 2 | 2 5/8 | 3 19/32 | 3/4 | 1 23/32 | 1 7/16 | 2 | 2 1/4-12 | 2 7/32 | 1 1/4-12 | 82,550 |
| AC-2-16 | 2 | 2 1/4 | 3 | 4 5/32 | 7/8 | 1 31/32 | 1 3/4 | 2 3/8 | 2 5/8-12 | 2 29/32 | 1 1/2-12 | 128,340 |
| AC-2-20 | 2 1/2 | 3 | 3 3/4 | 5 7/16 | 1 | 2 15/32 | 2 1/8 | 3 | 3 1/4-12 | 1 5/16 | 1 7/8-12 | 231,000 |
| AC-2-24 | 3 | 3 1/2 | 4 1/4 | 6 3/16 | 1 | 2 31/32 | ▲ | 3 3/8 | 3 3/4-12 | 1 3/16 | 2 1/4-12 | 289,200 |
| AC-2-28 | 3 1/2 | 3 1/2 | 5 | 6 7/16 | 1 | 3 15/32 | ▲ | 4 | 4 1/2-12 | 1 1/2 | 2 1/2-12 | 342,400 |
| AC-2-36 | 4 1/2 | 4 1/2 | 6 | 7 7/8 | 1 | 4 15/32 | ▲ | 4 3/4 | 5 1/4-12 | 1 5/8 | 3 1/4-12 | 475,500 |
| AC-2-44 | 5 1/2 | 5 1/2 | 7 1/4 | 9 3/8 | 1 | 5 15/32 | ▲ | 5 3/4 | 6 1/2-12 | 1 7/8 | 4-12 | 750,010 |

▲ Four 1/2" diameter x 1/2" deep spanner holes instead of flats.

Rod End Coupling

Used with the Hydro-Line style 10 Rod End, the Hydro-Line Rod End Coupling provides for close lateral alignment between the rod end and machine member.

The two-piece steel coupling features high tensile strength socket head cap screws (with safety factor designed to take full load), permits quick assembly/disassembly for fast and easy installation and servicing.

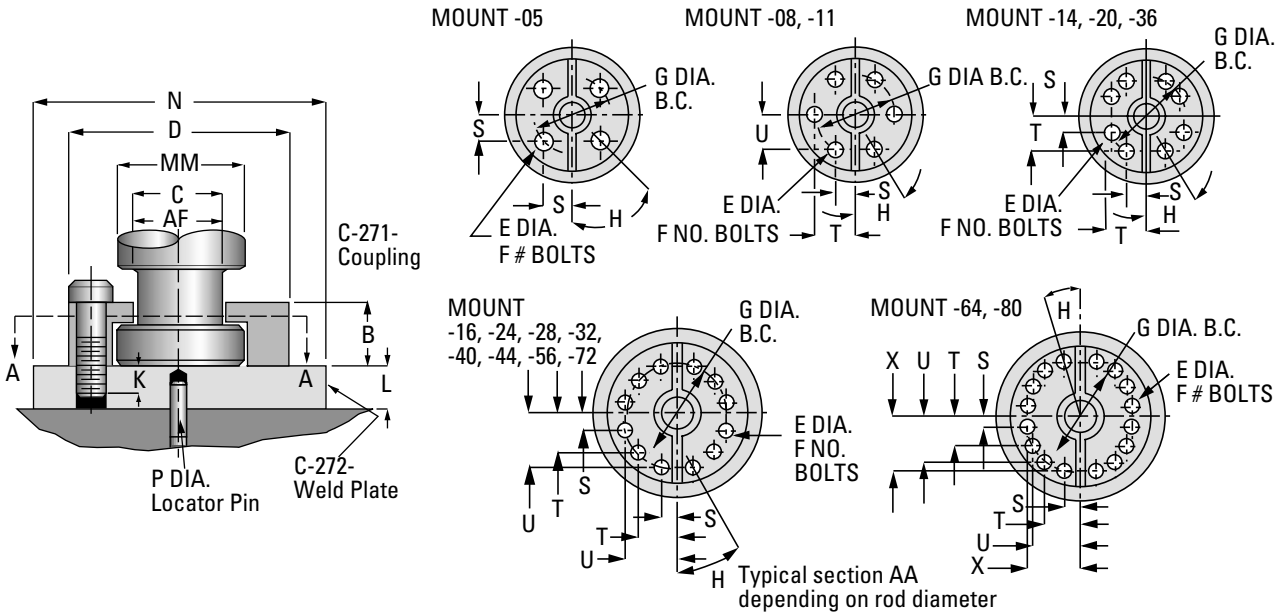
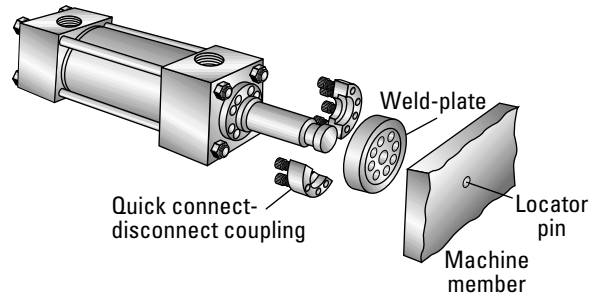

| Coupling | Rod Dia. MM | AF | B | C | D | E | F | G | H | K | Weld Plate C-272- | L | N | P | Soc. Hd. Cap Screws | Bolt Torq. Ft. lb. | S | T | U | X |
|----------|-------------|------|------|------|-------|-------|----|-------|---------|------|-------------------|------|-------|-----|---------------------|--------------------|-------|-------|-------|-------|
| C-271-05 | .625 | .38 | .44 | .41 | 1.50 | .218 | 4 | 1.12 | 45° | .44 | C-272-05 | .50 | 2.00 | .25 | #10-24x.88 | 5 | .398 | - | - | - |
| C-271-08 | 1.000 | .69 | .62 | .75 | 2.00 | .281 | 6 | 1.50 | 30° | .38 | C-272-08 | .50 | 2.50 | .25 | 1/4"-20x1.0 | 14 | .375 | .750 | .650 | - |
| C-271-11 | 1.375 | .88 | .69 | .94 | 2.50 | .343 | 6 | 2.00 | 30° | .56 | C-272-11 | .62 | 3.00 | .25 | 5/16"-18x1.25 | 30 | .500 | 1.000 | .866 | - |
| C-271-14 | 1.750 | 1.12 | .88 | 1.18 | 3.00 | .406 | 8 | 2.38 | 22° 30' | .62 | C-272-14 | .75 | 3.50 | .25 | 3/8"-16x1.5 | 52 | .454 | 1.097 | - | - |
| C-271-16 | 2.000 | 1.38 | 1.25 | 1.44 | 3.50 | .406 | 12 | 2.69 | 15° | .75 | C-272-16 | .88 | 4.00 | .38 | 3/8"-16x2.0 | 52 | .348 | .950 | 1.298 | - |
| C-271-20 | 2.500 | 1.75 | 1.38 | 1.88 | 4.25 | .531 | 8 | 3.44 | 22° 30' | .88 | C-272-20 | 1.00 | 5.00 | .38 | 1/2"-13x2.25 | 128 | .658 | 1.588 | - | - |
| C-271-24 | 3.000 | 2.25 | 1.88 | 2.38 | 5.00 | .531 | 12 | 4.00 | 15° | .88 | C-272-24 | 1.00 | 5.50 | .38 | 1/2"-13x2.75 | 128 | .518 | 1.414 | 1.932 | - |
| C-271-28 | 3.500 | 2.50 | 2.00 | 2.62 | 5.88 | .656 | 12 | 4.69 | 15° | 1.00 | C-272-28 | 1.12 | 6.50 | .38 | 5/8"-11x3.0 | 255 | .607 | 1.657 | 2.264 | - |
| C-271-32 | 4.000 | 3.00 | 2.00 | 3.12 | 6.38 | .656 | 12 | 5.18 | 15° | 1.00 | C-272-32 | 1.12 | 7.00 | .38 | 5/8"-11x3.0 | 255 | .671 | 1.834 | 2.505 | - |
| C-271-36 | 4.500 | 3.50 | 2.38 | 3.62 | 6.88 | .781 | 8 | 5.69 | 22° 30' | 1.12 | C-272-36 | 1.25 | 7.50 | .38 | 3/4"-10x3.5 | 450 | 1.088 | 2.627 | - | - |
| C-271-40 | 5.000 | 3.88 | 2.50 | 4.00 | 7.38 | .656 | 12 | 6.18 | 15° | 1.25 | C-272-40 | 1.38 | 8.00 | .38 | 5/8"-11x3.75 | 255 | .801 | 2.188 | 2.988 | - |
| C-271-44 | 5.500 | 4.38 | 3.12 | 4.50 | 8.25 | .781 | 12 | 6.88 | 15° | 1.38 | C-272-44 | 1.50 | 9.00 | .38 | 3/4"-10x4.5 | 450 | .890 | 2.431 | 3.320 | - |
| C-271-56 | 7.000 | 5.75 | 4.00 | 5.94 | 10.38 | 1.031 | 12 | 8.75 | 15° | 1.50 | C-272-56 | 1.75 | 11.00 | .50 | 1"-8x5.5 | 1090 | 1.132 | 3.094 | 4.226 | - |
| C-271-64 | 8.000 | 6.50 | 4.00 | 6.69 | 11.38 | 1.031 | 16 | 9.75 | 11° 15' | 1.50 | C-272-64 | 2.00 | 12.00 | .50 | 1"-8x5.5 | 1090 | .951 | 2.708 | 4.053 | 4.781 |
| C-271-72 | 9.000 | 7.25 | 4.00 | 7.50 | 13.12 | 1.281 | 12 | 11.12 | 15° | 2.00 | C-272-72 | 2.25 | 14.00 | .50 | 1 1/4"-7x6 | 2180 | 1.440 | 3.933 | 5.373 | - |
| C-271-80 | 10.000 | 8.00 | 4.50 | 8.25 | 14.12 | 1.281 | 16 | 12.12 | 11° 15' | 2.00 | C-272-80 | 2.50 | 15.00 | .50 | 1 1/4"-7x6.5 | 2180 | 1.183 | 3.368 | 5.040 | 5.946 |

To order C-271- and C-272- as an assembly, use part no. C-275-__

Custom Cylinders

For Special Applications

Eaton's full line of cylinder products and options fit most customers' application requirements, however, a special cylinder is often required to meet custom specifications. These custom cylinders are often needed to solve difficult application problems, upgrade existing equipment or are designed into new machinery.

Eaton's Sales, Engineering and Manufacturing groups are cylinder specialists and have many years of experience in the interpretation of requirements, design and manufacture of custom cylinder products.



Commitment to Quality

Eaton's policy is to design, produce and deliver defect-free products and provide superior services, the first time and every time, that consistently meet the needs of our customers. Our philosophy calls upon every employee to strive for excellence in customer satisfaction through continuous improvement.

Eaton would appreciate an opportunity to submit a proposal to solve your application problem or fulfill your current cylinder requirements. Simply copy and complete the Application Data Sheet on page 9 and fax to your authorized Eaton Hydro-Line distributor.



Our capabilities include

- Bore diameters to 30"
- Stroke lengths to 300"
- Operating pressures to 10,000 psi or higher
- Operating mediums ranging from shop air to nitrogen, or from standard hydraulic fluid to special synthetic fluids
- Tie rod, threaded and bolted cylinder construction
- Finite element analysis
- Application simulation in our testing laboratories

Rod End Styles

Choose from Eight

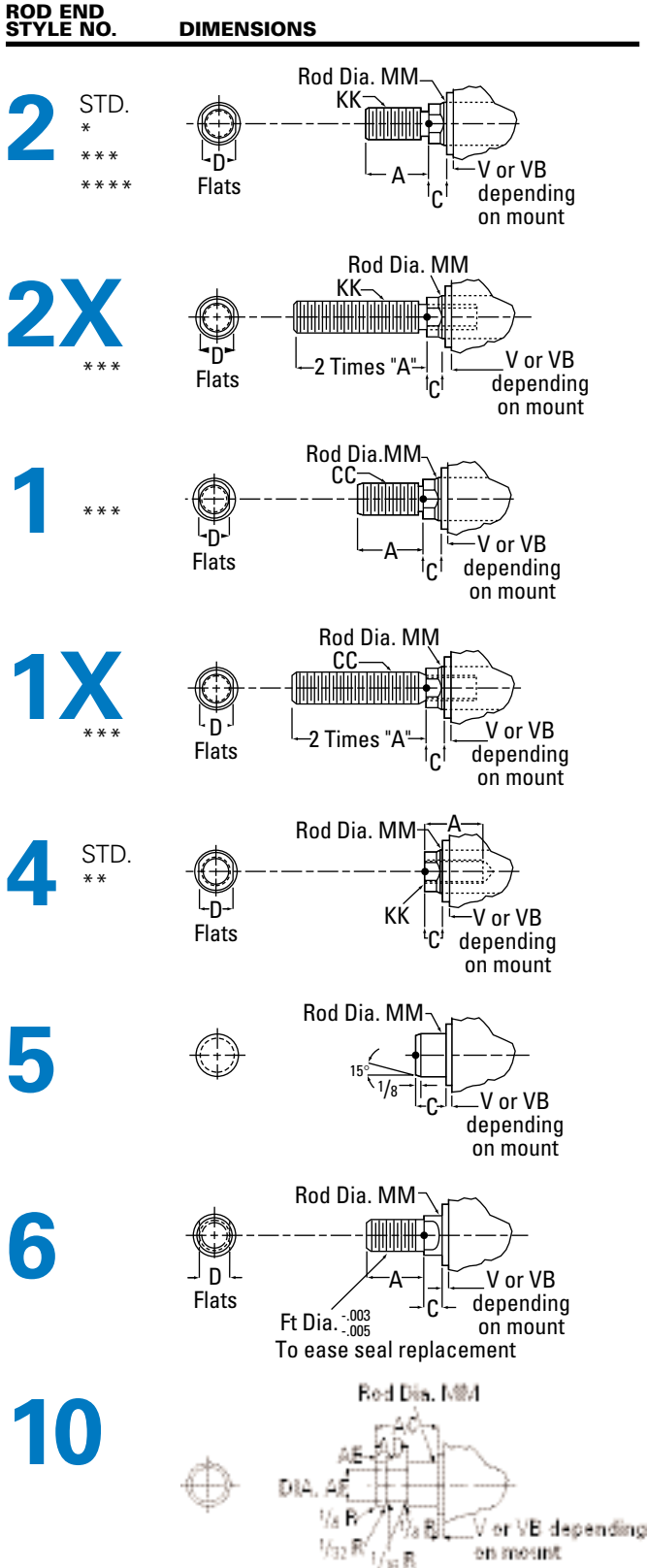

- * Male Rod End Style No. 2 is standard and will be furnished unless otherwise specified.
- ** Rod End Style No. 4 will be furnished when female thread is required unless otherwise specified.
- *** Rod End Styles No. 1, 1X, 2 and 2X are furnished studded on 5/8", 1" and 1 3/8" diameter rods. Larger sizes are of one-piece construction.
- **** All Hydro-Line mounting accessories are designed to fit No. 2 and 2X rod end styles only.

Note
A 1/8" long taper begins 1/16" from pilot face and leads to the turned down diameter, except on Rod Styles No. 5 and 6.

Note
Consult distributor for rod end configurations other than those shown.

Oversize Rod Information

The dimensions listed on these two pages are those that change when oversize rods are used.

Dimensions shown in blue are mounting dimensions.

▲ Mount B not available with standard dimensions in these sizes. Contact Hydro-Line for special dimensions.

‡ If no dimension is given, use FH dimension in place of F dimension and VB dimension in place of V dimension.

□ Four 1/2" diameter spanner holes used instead of wrench flats on 4" diameter and larger.

Note - Consult Hydro-Line for 20", 24" and 30" bore dimensions.

* Add stroke to all starred dimensions.

■ Refer to lower half of page 21.

** Plus 2 x stroke.

• Port dimensions for standard ports only. Consult Hydro-Line for flange, manifold and special ports.

| Bore | MM | KK | CC | FT | A | AC | AD | AE | AF | B ^{.001 .003} | C | D | F‡ | V‡ | W | WF | Y [•] NPTF SAE | RM | TK | VB | XC* | XD* | XE* | XG | XI | XJ* | XS | XT | XX* | ZB* | ZE* | ZF* | ZJ* | ZL* | ZM** | ZT* |
|-------|--------|----------|----------|----------|-------|-------|---------|-------|--------|----------------------------|-----|-------|---------|--------|-------|--------|----------------------------|----------|---------|-----|---------|--------|---------|---------|----|----------|---------|---------|---------|----------|---------|----------|---------|----------|--------|----------|
| 1 1/2 | ▲1 | 3/4-16 | 7/8-14 | 1-14 | 1 1/8 | 1 1/2 | 1 5/16 | 3/8 | 1 1/16 | 1 1/2 | 1/2 | 7/8 | - | - | 1 | 1 3/8 | 2 15/32 | ■ | 1/2 | 1/2 | 6 3/4 | 7 1/8 | 6 7/8 | 2 1/4 | | 5 1/4 | 1 3/4 | 2 3/8 | 7 1/2 | 6 3/8 | 7 1/4 | 6 3/8 | 6 | 6 5/8 | 7 5/8 | 7 3/8 |
| 2 | ▲1 3/8 | 1-14 | 1 1/4-12 | 1 3/8-12 | 1 5/8 | 1 3/4 | 1 1/16 | 3/8 | 7/8 | 2 | 5/8 | 1 1/8 | - | - | 1 | 1 5/8 | 2 23/32 | ■ | 1/2 | 3/8 | 7 1/2 | 8 1/8 | 7 3/16 | 2 1/2 | | 5 1/2 | 2 1/8 | 2 5/8 | 8 1/16 | 6 11/16 | 7 11/16 | 6 7/8 | 6 1/4 | 7 1/8 | 8 1/8 | 8 1/16 |
| 2 1/2 | ▲1 3/8 | 1-14 | 1 1/4-12 | 1 3/8-12 | 1 5/8 | 1 3/4 | 1 1/16 | 3/8 | 7/8 | 2 | 5/8 | 1 1/8 | - | - | 1 | 1 5/8 | 2 23/32 | ■ | 9/16 | 3/8 | 7 5/8 | 8 1/4 | 7 5/16 | 2 1/2 | | 5 5/8 | 2 5/16 | 2 5/8 | 8 3/16 | 6 13/16 | 7 13/16 | 7 | 6 3/8 | 7 1/4 | 8 1/4 | 8 3/16 |
| | ▲1 3/4 | 1 1/4-12 | 1 1/2-12 | 1 3/4-12 | 2 | 2 | 1 5/16 | 1/2 | 1 1/8 | 2 3/8 | 3/4 | 1 1/2 | - | - | 1 1/4 | 1 7/8 | 2 31/32 | ■ | 5/16 | 1/2 | 7 7/8 | 8 1/2 | 7 9/16 | 2 3/4 | | 5 7/8 | 2 9/16 | 2 7/8 | 8 7/16 | 7 1/16 | 8 1/16 | 7 1/4 | 6 5/8 | 7 1/2 | 8 3/4 | 8 7/16 |
| 3 1/4 | 1 3/4 | 1 1/4-12 | 1 1/2-12 | 1 3/4-12 | 2 | 2 | 1 5/16 | 1/2 | 1 1/8 | 2 3/8 | 3/4 | 1 1/2 | - | - | 1 1/8 | 1 7/8 | 2 31/32 | ■ | 3/4 | 3/8 | 8 7/8 | 9 5/8 | 8 1/2 | 2 7/8 | | 6 1/2 | 2 9/16 | 3 | 9 1/2 | 7 15/16 | 9 1/8 | 8 1/8 | 7 3/8 | 8 3/8 | 9 1/2 | 9 11/16 |
| | ▲2 | 1 1/2-12 | 1 3/4-12 | 2-12 | 2 1/4 | 2 5/8 | 1 11/16 | 5/8 | 1 3/8 | 2 5/8 | 7/8 | 1 3/4 | - | - | 1 1/4 | 2 | 3 3/32 | ■ | 1/2 | 3/8 | 9 | 9 3/4 | 8 5/8 | 3 | | 6 5/8 | 2 11/16 | 3 1/8 | 9 5/8 | 8 1/16 | 9 1/4 | 8 1/4 | 7 1/2 | 8 1/2 | 9 3/4 | 9 13/16 |
| 4 | ▲2 | 1 1/2-12 | 1 3/4-12 | 2-12 | 2 1/4 | 2 5/8 | 1 11/16 | 5/8 | 1 3/8 | 2 5/8 | 7/8 | 1 3/4 | 19/32 | 17/32 | 1 1/8 | 2 | 3 3/32 | 4 | 3/4 | 1/4 | 9 7/8 | 10 3/4 | 8 7/8 | 3 | | 6 7/8 | 2 7/8 | 3 1/8 | 10 | 8 5/16 | 9 1/2 | 8 5/8 | 7 3/4 | 8 19/32 | 10 | 10 1/16 |
| | ▲2 1/2 | 1 7/8-12 | 2 1/4-12 | 2 1/2-12 | 3 | 3 1/4 | 1 15/16 | 3/4 | 1 3/4 | 3 1/8 | 1 | 2 1/8 | 19/32 | 2 1/32 | 1 3/8 | 2 1/4 | 3 11/32 | 4 7/16 | 1 11/16 | 3/8 | 10 1/8 | 11 | 9 1/8 | 3 1/4 | | 7 1/8 | 3 1/8 | 3 3/8 | 10 1/4 | 8 9/16 | 9 3/4 | 8 7/8 | 8 | 8 27/32 | 10 1/2 | 10 5/16 |
| 5 | 2 1/2 | 1 7/8-12 | 2 1/4-12 | 2 1/2-12 | 3 | 3 1/4 | 1 15/16 | 3/4 | 1 3/4 | 3 1/8 | 1 | 2 1/8 | 19/32 | 2 1/32 | 1 3/8 | 2 1/4 | 3 11/32 | 4 7/16 | 1 11/8 | 3/8 | 10 3/4 | 11 5/8 | 10 | 3 1/4 | | 7 5/8 | 3 1/8 | 3 3/8 | 11 1/8 | 9 5/16 | 10 3/4 | 9 3/8 | 8 1/2 | 9 11/32 | 11 | 11 11/16 |
| | 3 | 2 1/4-12 | 2 3/4-12 | 3-12 | 3 1/2 | 3 5/8 | 2 7/16 | 7/8 | 2 1/4 | 3 3/4 | 1 | 2 5/8 | 23/32 | 17/32 | 1 3/8 | 2 1/4 | 3 11/32 | 5 1/4 | 1 11/8 | 3/8 | 10 3/4 | 11 5/8 | 10 | 3 1/4 | | 7 5/8 | 3 1/8 | 3 3/8 | 11 1/8 | 9 5/16 | 10 3/4 | 9 3/8 | 8 1/2 | 9 15/32 | 11 | 11 11/16 |
| | ▲3 1/2 | 2 1/2-12 | 3 1/4-12 | 3 1/2-12 | 3 1/2 | 4 3/8 | 2 11/16 | 1 | 2 1/2 | 4 1/4 | 1 | 3 | 23/32 | 17/32 | 1 3/8 | 2 1/4 | 3 11/32 | 5 5/8 | 3/4 | 3/8 | 10 3/4 | 11 5/8 | 10 | 3 1/4 | | 7 5/8 | 3 1/8 | 3 3/8 | 11 1/8 | 9 5/16 | 10 3/4 | 9 3/8 | 8 1/2 | 9 15/32 | 11 | 11 11/16 |
| 6 | 3 | 2 1/4-12 | 2 3/4-12 | 3-12 | 3 1/2 | 3 3/4 | 2 7/16 | 7/8 | 2 1/4 | 3 3/4 | 1 | 2 5/8 | 23/32 | 17/32 | 1 1/4 | 2 1/4 | 3 19/32 | 5 1/4 | 1 5/16 | 1/4 | 12 1/8 | 13 1/8 | 11 5/16 | 3 3/8 | | 8 3/8 | 3 3/8 | 3 1/2 | 12 5/16 | 10 9/16 | 12 3/16 | 10 5/8 | 9 5/8 | 10 11/32 | 11 7/8 | 13 1/4 |
| | 3 1/2 | 2 1/2-12 | 3 1/4-12 | 3 1/2-12 | 3 1/2 | 4 3/8 | 2 11/16 | 1 | 2 1/2 | 4 1/4 | 1 | 3 | 23/32 | 17/32 | 1 1/4 | 2 1/4 | 3 19/32 | 5 5/8 | 1 5/16 | 1/4 | 12 1/8 | 13 1/8 | 11 5/16 | 3 3/8 | | 8 3/8 | 3 3/8 | 3 1/2 | 12 5/16 | 10 9/16 | 12 3/16 | 10 5/8 | 9 5/8 | 10 11/32 | 11 7/8 | 13 1/4 |
| | ▲4 | 3-12 | 3 3/4-12 | 4-12 | 4 | 4 1/2 | 2 11/16 | 1 | 3 | 4 3/4 | 1 | □ | 7/8 | 3/8 | 1 1/4 | 2 1/4 | 3 19/32 | 6 7/16 | 7/8 | 1/4 | 12 1/8 | 13 1/8 | 11 5/16 | 3 3/8 | | 8 3/8 | 3 3/8 | 3 1/2 | 12 5/16 | 10 9/16 | 12 3/16 | 10 5/8 | 9 5/8 | 10 1/2 | 11 7/8 | 13 1/4 |
| 7 | 3 1/2 | 2 1/2-12 | 3 1/4-12 | 3 1/2-12 | 3 1/2 | 4 3/8 | 2 11/16 | 1 | 2 1/2 | 4 1/4 | 1 | 3 | 23/32 | 17/32 | 1 1/4 | 2 1/4 | 3 15/16 | 5 5/8 | 2 1/8 | 1/4 | 13 3/4 | 14 3/4 | 12 9/16 | 3 5/8 | | 9 3/8 | 3 5/8 | 3 13/16 | 13 9/16 | 11 3/4 | 13 9/16 | 11 3/4 | 10 3/4 | 11 15/32 | 13 | 14 7/8 |
| | 4 | 3-12 | 3 3/4-12 | 4-12 | 4 | 4 1/2 | 2 11/16 | 1 | 3 | 4 3/4 | 1 | □ | 7/8 | 3/8 | 1 1/4 | 2 1/4 | 3 15/16 | 6 7/16 | 1 3/4 | 1/4 | 13 3/4 | 14 3/4 | 12 9/16 | 3 5/8 | | 9 3/8 | 3 5/8 | 3 13/16 | 13 9/16 | 11 3/4 | 13 9/16 | 11 3/4 | 10 3/4 | 11 5/8 | 13 | 14 7/8 |
| | ▲4 1/2 | 3 1/4-12 | 4 1/4-12 | 4 1/2-12 | 4 1/2 | 5 1/4 | 3 3/16 | 1 1/2 | 3 1/2 | 5 1/4 | 1 | □ | 7/8 | 3/8 | 1 1/4 | 2 1/4 | 3 15/16 | 7 1/8 | 7/8 | 1/4 | 13 3/4 | 14 3/4 | 12 9/16 | 3 5/8 | | 9 3/8 | 3 5/8 | 3 13/16 | 13 9/16 | 11 3/4 | 13 9/16 | 11 3/4 | 10 3/4 | 11 5/8 | 13 | 14 7/8 |
| | ▲5 | 3 1/2-12 | 4 3/4-12 | 5-12 | 5 | 5 3/8 | 3 3/16 | 1 1/2 | 3 7/8 | 5 3/4 | 1 | □ | 7/8 | 3/8 | 1 1/4 | 2 1/4 | 3 15/16 | 7 9/16 | 7/8 | 1/4 | 13 3/4 | 14 3/4 | 12 9/16 | 3 5/8 | | 9 3/8 | 3 5/8 | 3 13/16 | 13 9/16 | 11 3/4 | 13 9/16 | 11 3/4 | 10 3/4 | 11 5/8 | 13 | 14 7/8 |
| 8 | 4 | 3-12 | 3 3/4-12 | 4-12 | 4 | 4 1/2 | 2 11/16 | 1 | 3 | 4 3/4 | 1 | □ | 7/8 | 3/8 | 1 1/4 | 2 1/4 | 4 1/16 | 6 7/16 | 1 9/16 | 1/4 | 15 | 16 | 13 3/4 | 3 3/4 | | 10 1/4 | 3 5/8 | 3 15/16 | 14 3/4 | 12 7/8 | 14 7/8 | 12 3/4 | 11 3/4 | 12 5/8 | 14 | 16 1/4 |
| | 4 1/2 | 3 1/4-12 | 4 1/4-12 | 4 1/2-12 | 4 1/2 | 5 1/4 | 3 3/16 | 1 1/2 | 3 1/2 | 5 1/4 | 1 | □ | 7/8 | 3/8 | 1 1/4 | 2 1/4 | 4 1/16 | 7 1/8 | 1 9/16 | 1/4 | 15 | 16 | 13 3/4 | 3 3/4 | | 10 1/4 | 3 5/8 | 3 15/16 | 14 3/4 | 12 7/8 | 14 7/8 | 12 3/4 | 11 3/4 | 12 5/8 | 14 | 16 1/4 |
| | 5 | 3 1/2-12 | 4 3/4-12 | 5-12 | 5 | 5 3/8 | 3 3/16 | 1 1/2 | 3 7/8 | 5 3/4 | 1 | □ | 7/8 | 3/8 | 1 1/4 | 2 1/4 | 4 1/16 | 7 9/16 | 1 9/16 | 1/4 | 15 | 16 | 13 3/4 | 3 3/4 | | 10 1/4 | 3 5/8 | 3 15/16 | 14 3/4 | 12 7/8 | 14 7/8 | 12 3/4 | 11 3/4 | 12 5/8 | 14 | 16 1/4 |
| | ▲5 1/2 | 4-12 | 5 1/4-12 | 5 1/2-12 | 5 1/2 | 6 1/4 | 3 15/16 | 1 7/8 | 4 3/8 | 6 1/4 | 1 | □ | 7/8 | 3/8 | 1 1/4 | 2 1/4 | 4 1/16 | 8 3/8 | 1 3/8 | 1/4 | 15 | 16 | 13 3/4 | 3 3/4 | | 10 1/4 | 3 5/8 | 3 15/16 | 14 3/4 | 12 7/8 | 14 7/8 | 12 3/4 | 11 3/4 | 12 5/8 | 14 | 16 1/4 |
| 10 | 5 | 3 1/2-12 | 4 3/4-12 | 5-12 | 5 | 5 3/8 | 3 3/16 | 1 1/2 | 3 7/8 | 5 3/4 | - | □ | 1 1/8 | 1 1/16 | - | 3 3/16 | 5 3/16 | 7 5/8 | - | - | 19 5/16 | - | - | 5 | | 13 1/2 | 4 13/16 | - | - | 17 | - | 17 | 15 5/16 | - | - | - |
| | 5 1/2 | 4-12 | 5 1/4-12 | 5 1/2-12 | 5 1/2 | 6 1/4 | 3 15/16 | 1 7/8 | 4 3/8 | 6 1/4 | - | □ | 1 3/8 | 1 3/16 | - | 3 3/16 | 5 3/16 | 8 3/8 | - | - | 19 5/16 | - | - | 5 | | 13 1/2 | 4 13/16 | - | - | 17 | - | 17 | 15 5/16 | - | - | - |
| | 7 | 5-12 | 6 1/2-12 | 7-12 | 7 | 6 1/2 | 4 1/16 | 2 | 5 3/4 | 8 | - | □ | 1 5/8 | 7/8 | - | 3 1/2 | 5 1/2 | 10 13/16 | - | - | 19 3/4 | - | - | 5 5/16 | | 13 13/16 | 5 1/8 | - | - | 17 5/16 | - | 17 5/16 | 15 5/8 | - | - | - |
| 12 | 7 | 5-12 | 6 1/2-12 | 7-12 | 7 | 6 1/2 | 4 1/16 | 2 | 5 3/4 | 8 | - | □ | 1 5/8 | 7/8 | - | 3 1/2 | 6 | 10 13/16 | - | - | 22 1/2 | - | - | 5 11/16 | | 15 13/16 | 5 1/2 | - | - | 20 | - | 19 15/16 | 18 | - | - | - |
| | 8 | 5 3/4-12 | 7 1/2-12 | 8-12 | 8 | 6 1/2 | 4 1/16 | 2 | 6 1/2 | 9 | - | □ | 1 7/8 | 1 1/8 | - | 4 | 6 1/2 | 12 3/8 | - | - | 23 | - | - | 6 3/16 | | 16 5/16 | 6 | - | - | 20 1/2 | - | 20 7/16 | 18 1/2 | - | - | - |
| 14 | 8 | 5 3/4-12 | 7 1/2-12 | 8-12 | 8 | 6 1/2 | 4 1/16 | 2 | 6 1/2 | 9 | - | □ | 1 7/8 | 1 1/8 | - | 4 | 6 7/8 | 12 3/8 | - | - | 25 3/8 | - | - | 6 7/16 | | 17 3/16 | 6 1/4 | - | - | 21 7/16 | - | 21 7/8 | 19 5/8 | - | - | - |
| | 9 | 6 1/2-12 | 8 1/2-12 | 9-12 | 9 | 6 3/4 | 4 1/8 | 2 | 7 1/4 | 10 | - | □ | 2 3/16 | 1 1/16 | - | 4 1/4 | 7 1/8 | 13 1/8 | - | - | 25 5/8 | - | - | 6 11/16 | | 17 7/16 | 6 1/2 | - | - | 21 7/8 | - | 22 1/8 | 19 7/8 | - | - | - |
| | 10 | 7 1/4-12 | 9 1/2-12 | 10-12 | 10 | 7 1/4 | 4 5/8 | 2 3/8 | 8 | 11 | - | □ | 2 11/16 | 1 3/16 | - | 4 1/2 | 7 3/8 | 14 5/8 | - | - | 25 7/8 | - | - | 6 15/16 | | 17 11/16 | 6 3/4 | - | - | 21 15/16 | - | 22 3/8 | 20 1/8 | - | - | - |
| 16 | 9 | 6 1/2-12 | 8 1/2-12 | 9-12 | 9 | 6 3/4 | 4 1/8 | 2 | 7 1/4 | 10 | | | | | | | | | | | | | | | | | | | | | | | | | | |



N5 SERIES CYLINDERS

- NFPA interchangeable
- N5 – 3000 psi nominal hydraulic
- AN5 – to 250 psi very heavy-duty pneumatic
- LAN5 – to 250 psi very heavy-duty pneumatic – permanently lubricated
- All steel construction



R5 SERIES CYLINDERS

- NFPA interchangeable
- A5/R5 – to 250 psi pneumatic
- LA5/LR5 – to 250 psi pneumatic – permanently lubricated
- HA5 – to 400 psi hydraulic
- HR5 – 1500 psi nominal hydraulic



Q6 SERIES CYLINDERS

- NFPA interchangeable
- Q6 – to 250 psi pneumatic permanently lubricated
- HQ6 – to 400 psi hydraulic
- 3/4" to 8" Bores



HM SERIES CYLINDERS

- Conform to international metric specifications ISO 6020/2 and DIN 24 554
- 25 mm to 200 mm bore sizes
- 210 BAR nominal hydraulic
- All steel construction



FIELD-MATE^{PLUS} SERIES CYLINDERS

- ASAE interchangeable agricultural cylinders
- Rated to 3000 psi hydraulic



ELECTRONIC FEEDBACK CYLINDERS

Hydraulic or pneumatic cylinders which incorporate cylinder position sensing and feedback throughout the stroke. Available in N5, R5, A5, Q5, HM, HVV, SM or special cylinders.



SERIES 20/30 BOOSTERS

- Standard series to 5000 psi output
- Custom designs to 20,000 psi



HW SERIES CYLINDERS

- Welded construction
- 3000 psi nominal hydraulic



TSAYER CYLINDERS

- Threaded body construction
- To 200 psi pneumatic
- To 1000 psi nominal hydraulic



SM SERIES CYLINDERS

- Steel mill type construction
- MSM–2000 psi nominal hydraulic
- HSM–3000 psi nominal hydraulic
- ASM–Pneumatic



CUSTOM CYLINDERS

Custom cylinders to meet special requirements

- Bores to 48"
- Strokes to 300"
- Pressures to 10,000 psi or higher

Eaton
14615 Lone Oak Road
Eden Prairie, MN 55344
USA
Tel: 952 937-9800
Fax: 952 974-7722
www.hydraulics.eaton.com

Eaton
1112 Brooks Street, S.E.
Decatur, AL 35601
Tel: 256 350-2339
Fax: 256 351-1264

Eaton
2425 W. Michigan Avenue
Jackson, MI 49202
Tel: 517 787-7220
Fax: 517 787 3450

Eaton
7638 Pacific Avenue
White City, OR 97503-1091
Tel: 541 826-2131
Fax: 541 826-3344



Hydro-Line

© 2003 Eaton Corporation
All Rights Reserved
Printed in USA
Document No. H-CYIG-TM002-E
September 2003