

EATON

Hydro-Line

**Pneumatic Cylinders
Light Duty**

L Series

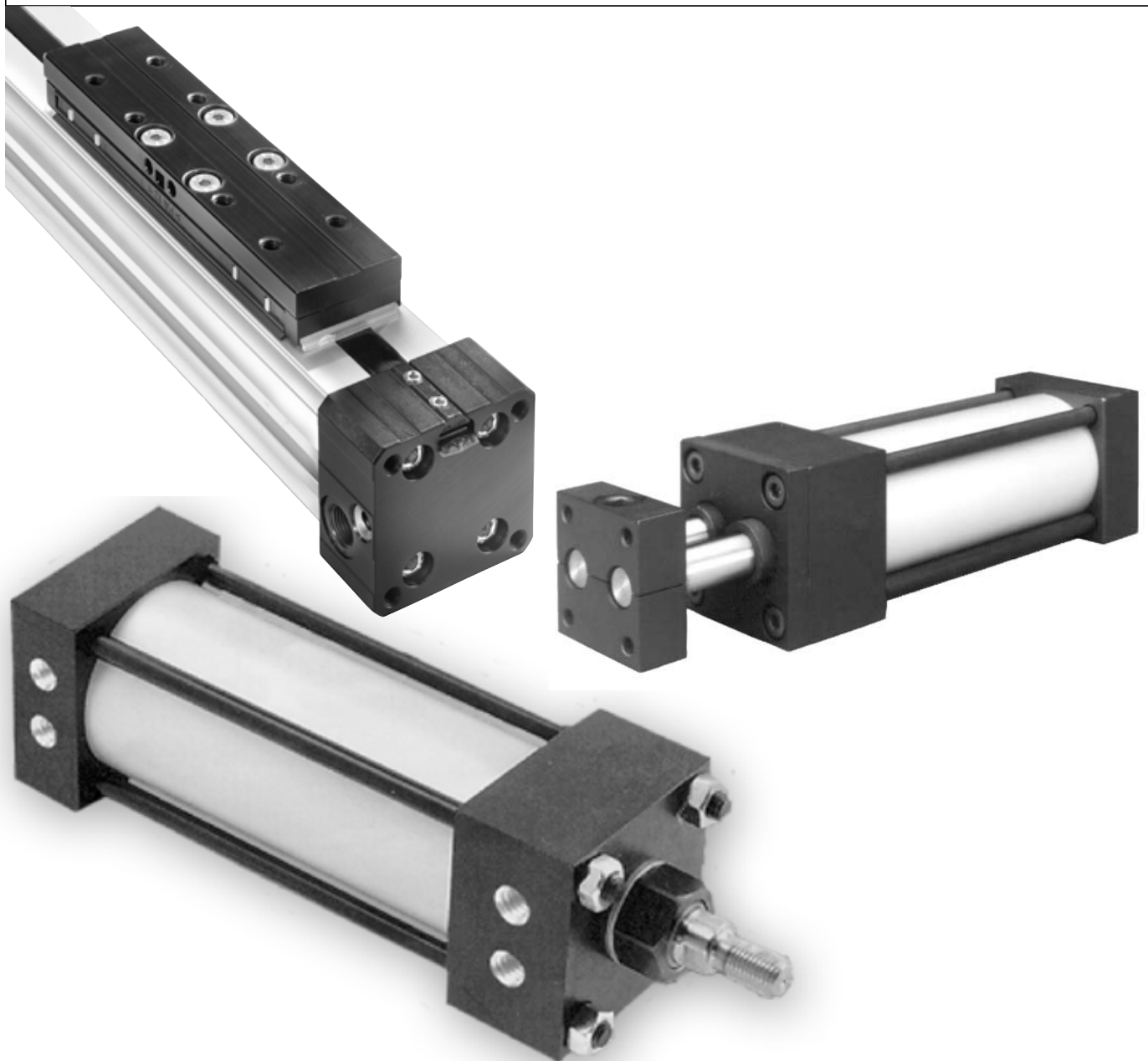

Table of Contents

How to Order.....	.01
L-Series Features and Benefits.....	.02
Series Q6 — NFPATie Rod	
Features.....	.03
Model Code.....	.04
Mounting Styles.....	.05
Accessories.....	.43
Technical Information.....	.61
Series ML — ISO/VDMA	
Features.....	.67
Model Code.....	.68
Mounting Styles.....	.69
Accessories.....	.75
Technical Information.....	.87
Series RL — Rodless	
Features.....	.88
Model Code.....	.89
Mounting Styles.....	.90
Accessories.....	.98
Technical Information.....	.100
Series BL — Non-Rotating	
Features.....	.103
Model Code.....	.104
Mounting Styles.....	.105
Accessories.....	.112
Technical Information.....	.115
Series SL — Stainless Steel NFPATie Rod	
Features.....	.116
Model Code.....	.117
Mounting Styles.....	.118
Accessories.....	.127
Technical Information.....	.131

How to Order

Standard Cylinders

Eaton has created an easy system for ordering Hydro-Line® Series Q6, ML, RL, BL or SL cylinders. This system has been developed to improve our service to you. The model code consists of sixteen alpha-numeric digits which fully describe the most common standard options offered on Series Q6, ML, RL, BL or SL cylinders.

To specify your Series Q6, ML, RL, BL or SL cylinder, review the following pages for a full description of each option available and select the desired code.

This model code system will:

- **Simplify the re-order process.**

Each Series Q6, ML, RL, BL or SL cylinder is assigned a 16 digit model code. That code is unique to a particular cylinder description. That way, when you re-order your Series Q6, ML, RL, BL or SL cylinder, you're assured of exactly the same top quality cylinder design.

- **Improve identification.**

Every Series Q6, ML, RL, BL or SL cylinder has its sixteen digit model code clearly labeled on the product. Each 16 digit code completely describes a specific cylinder. This allows seals and replacement components to be easily identified in the field.

- **Facilitate communications.**

This fully descriptive model code system allows you to work directly with your local Eaton sales engineer to identify and service your Hydro-Line cylinder.

NOTE

See pages 4, 68, 89, 104 and 116 for a summary of model code options.

Custom Cylinders

Although the model code has been arranged to cover the vast majority of available options, there will be occasions when you require an option which cannot be coded. When specifying such an option, enter an "X" for the appropriate item in the sixteen digit model code, then describe your requirements. For example, if you have an application which requires a custom thread on the end of the piston rod, enter an "X" for item 7. Then add a full description at the end of the model code, such as "With 3.25 inch total rod projection and M22 x 1.5 thread 1.375 inches long." The cylinder will then be given a unique five digit design number on receipt of order (as explained below).

Replacement Cylinders

Every custom cylinder is assigned a unique design number. This number is contained in the last five digits of the 27 digit model code. In other words, the last six locations become the "Design Number" items for custom cylinders. When ordering a replacement cylinder, simply give the 27 digit model code or the five digit design number to your local Sales Representative.





Replacement Parts

Each design number is stored in a quick retrieval computerized storage system. This gives our field sales representatives rapid access to assist you in identifying and specifying genuine Hydro-Line replacement parts.

Warranty

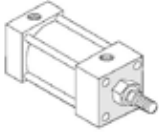
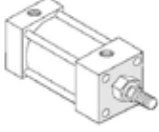
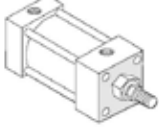
Eaton is proud to offer a comprehensive two year warranty on the L Series pneumatic cylinders.

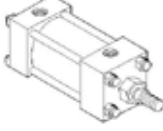
L-Series Features and Benefits

Product Name/Description	Key Applications	Features/Benefits	
Non-Lubricated Air/Hydraulic Cylinder Q6 Series 	Packaging, bottling, machine tool	<ul style="list-style-type: none"> • High strength steel design for robust performance • Superior cushion seal design for smoother, faster operation 	<ul style="list-style-type: none"> • Wide range of standard options for faster response
Corrosion Resistant Air Cylinder (NFPA) NQ Series 	Packaging, bottling, machine tool	<ul style="list-style-type: none"> • Unique hybrid aluminum/stainless combination for ultimate corrosion protection at a better price 	<ul style="list-style-type: none"> • Better performance & protection than competitive aluminum products
ISO 6431/VDMA 24562 Air Cylinder ML Series 	Packaging, bottling, material handling, machine tool, auto assembly, commercial laundry	<ul style="list-style-type: none"> • ISO 6431/VDMA 24562 dimensionally interchangeable • Tie rod design with smooth body 	<ul style="list-style-type: none"> • Broad standard options for flexibility • Collar nut design for bolt-on mountings • Fast product delivery
Rodless Air Cylinder RL Series 	Paper mill, textiles, material handling, packaging, transfer lines	<ul style="list-style-type: none"> • Unique sealing system with higher pressure rating in industry • Lightweight, space saving design built at 50% space of conventional cylinders 	<ul style="list-style-type: none"> • Long strokes without rod buckling risk; high load carrying capability • Simple, cost-effective guide options • Designed for serviceability
Stainless Steel Air Cylinder (NFPA) SL Series 	Food processing, medical, packaging, milking parlors, automatic car washes	<ul style="list-style-type: none"> • NFPA tie rod dimensionally interchangeable • Superior corrosion resistance for tough environments 	<ul style="list-style-type: none"> • Robust design with non-metallic piston wear band, composite bearing insert, and stainless steel rod cartridge
Non-Rotating Cylinders (NFPA) BL Series 	Machine tool, fixturing, clamping, packaging	<ul style="list-style-type: none"> • NFPA interchangeable • Twin rod design for non-rotating, anti-torque applications 	

Series Q6/NQ Features

Wiper Seal

Urethane wiper seal keeps contaminants from getting into cylinder by aggressively wiping foreign materials from the piston rod, enhancing the rod seal life.

Head/Cap

Precision machined from alloy aluminum, then black anodized for corrosion resistance in Series Q6, and electroless nickel plated for Series NQ option.

Adjustable Captive Cushion Adjusting Screw

One-piece stainless steel cushion screw with fine threads is held captive by a stainless steel press-in retaining washer. This allows for safe and precise adjustment of the cushion without inadvertent removal.

Cylinder Body

High-strength aluminum alloy tubing is clear anodized on the O.D. and hard anodic coated on the I.D., resulting in a smooth, file hard (60RC), corrosion and score resistant surface finish for extended seal life in Series Q6. Stainless steel tubing is used in Series NQ option.

Tie Rods

High-strength steel in Series Q6, and stainless steel for Series NQ option, maintains uniform compression on body end seals.

Wear Ring

Reinforced Teflon® compounded with polyphenylene sulfide provides supreme wear and excellent bearing support.

Teflon® and Viton® are registered trademarks of E.I. DuPont Company.

Piston Rod

Hard chrome plated high-tensile carbon steel, ground and polished in Series Q6, and stainless steel for Series NQ option.

Rod Bearing

Externally removable threaded steel bearing cartridge with black oxide finish in Series Q6, or stainless steel for Series NQ option, both with an oil-impregnated sintered iron rod bearing.

Rod Seal

Nitrile lip-type seal is pressure energized and wear compensating for durability and long life.

O-Ring Body Seal

Nitrile material is standard, with Viton® optional.

Super Cushion Seals

Advanced design features a unique, one-piece, compound seal of nitrile* captured within a precision machined groove. Linear and radial "float" of the cushion seals eliminates misalignment. Super Cushions provide exceptionally fast "out of cushion" stroke reversal. (Head and Cap Cushions are optional on 1-1/2 thru 8 inch bore cylinders.) *Nitrile seals on the 5/8" & 1" rod diameter. For rod sizes 1-3/8" and larger, urethane seals are standard.

Piston

Machined solid aluminum alloy, light-weight for low inertia, yet strong. (Threaded and installed with high strength threadlocker adhesive.)

Piston Seals

Long-wearing nitrile cup seals.

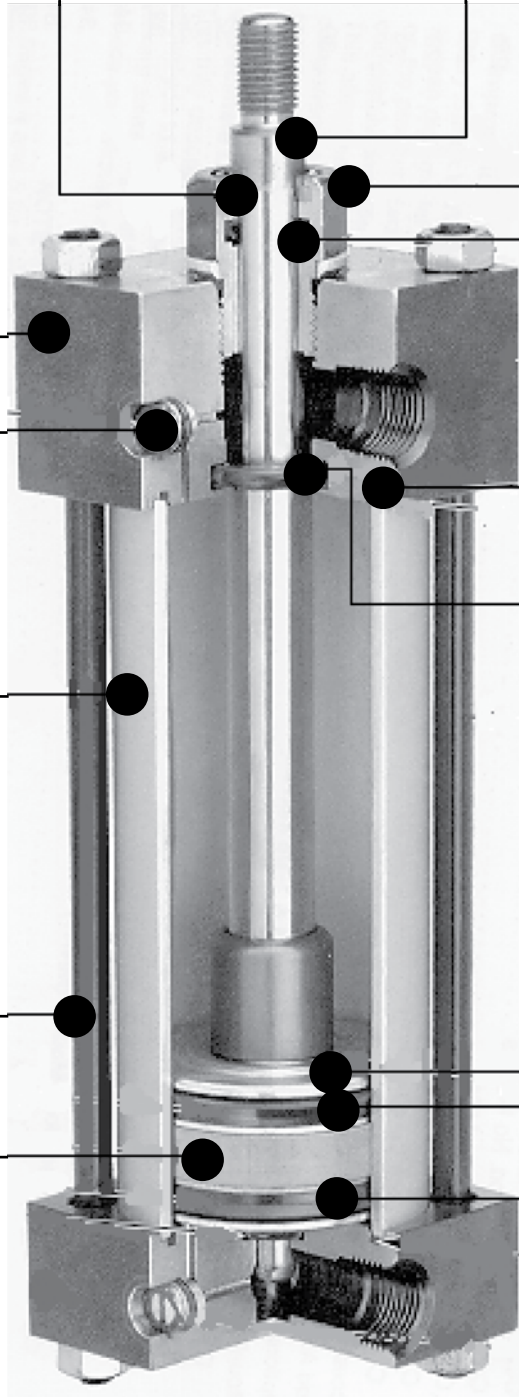

Series Q6/NQ/HQ Model Code

Q6 AS 00 75 010.00 N 00.31 5 N N N 1 1 0 C

1, 2 3, 4 5, 6 7, 8 9, 10, 11, 12, 13 14 15, 16, 17, 18 19 20 21 22 23 24 25 26

1, 2 Series (ANSI B93, 15/NFPA)

Q6 – Non-lubricated air/hydraulic cylinder
NQ – Corrosion resistant air cylinder
HQ – Hydraulic, 400 psi

3, 4 Mounting Style

Code	Style	ANSI Code
	1-1/2 thru 8" Bore	

AS	– Side lug	MS2
BS	– Side tapped	MS4
ES	– End lug	MS7
FS	– Head rectangular flange	MF1
GG	– Head square	ME3
CF	– Cap fixed clevis	MP1
RS	– Cap rectangular flange	MF2
PP	– Cap square	ME4
WS	– Cap trunnion	MT2
US	– Head trunnion	MT1
FM	– Sleeve nut for tapped face	–
NS	– Cap extended tie rod	MX2
MS	– Head extended tie rod	MX3
LS	– Both ends extended tie rod	MX1
KS	– No mounts MX0	
KD	– Double rod, no mounts	–
YY	– Angle	MS1
DE	– Detachable eye	MP4
DC	– Detachable clevis	MP2

3/4 thru 1-1/8 Bore

EE	– Bolt thru	MS8
BS	– Tapped	MS9
FS	– Head rectangular flange	MF1
RS	– Cap rectangular flange	MF2
FM	– Head tapped face	MR1
TN	– Threaded nose	MNR1
KS	– No mounts	MX0
ED	– Double rod w/bolt thru	–
CM	– Fixed eye	MP3
DE	– Detachable eye	MP4
DC	– Detachable clevis	MP2

5, 6, 7, 8 Bore

Specify in inches (2 position decimal)
 00.75 – 3/4" bore
 01.50 – 1-1/2" bore
 02.00 – 2" bore
 02.50 – 2-1/2" bore
 03.25 – 3-1/4" bore
 04.00 – 4" bore
 05.00 – 5" bore
 06.00 – 6" bore
 07.00 – 7" bore
 08.00 – 8" bore

9, 10, 11, 12, 13 Stroke

Specify length in inches (3 positions to the left of decimal and 2 positions to the right) for example:

Code	Size
004.50	4.50
010.00	10
112.50	112.50 etc.

14 Cushions

Cushions are located as shown below when viewing cylinder from head end (mounting end of double rod cylinders). "–" in table indicates no cushion.

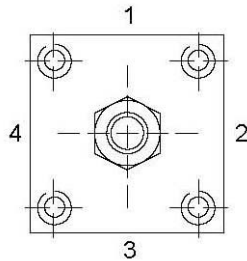

Code	Head	Cap
N	–	–
C	–	2
H	2	–
B	2	2
A	1	–
D	3	–
E	4	–
F	–	1
G	–	3
J	–	4

15, 16, 17, 18 Rod Diameter

Specify in inches (2 position decimal)
 00.31 – 5/16" Rod Dia.
 00.38 – 3/8" Rod Dia.
 00.50 – 1/2" Rod Dia.
 01.00 – 1" Rod Dia.
 01.38 – 1-3/8" Rod Dia.
 01.75 – 1-3/4" Rod Dia.

19 Rod End Types

Code	Rod End Type
4	Short Female UN Thread



2	Small Male UN Thread
---	----------------------

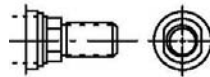

5	Plain – No Attachment
---	-----------------------

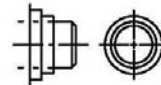

I	Int. Male UN Thread
---	---------------------

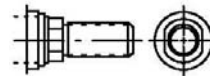

S	Studded Female UN Thread
---	--------------------------

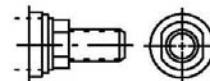

20 Ports

Code	Port Style
N	Standard
L	Oversized (NFPA)

21 Rod Seals

P – Polypak
N – Nitrile Lip Type
V – Vitron Lip Type

22 Piston Seals

N – Nitrile Lip Type
V – Vitron Lip Type

23, 24 Port Location

1-4 – Head End Position
1-4 – Cap End Position

25, 26 Special Modifications

Extra Rod Projection

Item 25 indicates inches from 0 thru 9. Item 26 indicates fraction of an inch per the following codes:

Code	Fraction	Code	Fraction
0	0	8	1/2
1	1/16	9	9/16
2	1/8	A	5/8
3	3/16	B	11/16
4	1/4	C	3/4
5	5/16	D	13/16
6	3/8	E	7/8
7	7/16	F	15/16

27 Custom

X – Custom Modification

Series Q6/NQ Cylinder Features

1-1/2 – 8 inch Bores

Available Mountings

The variety of standard ANSI/NFPA mountings available in 1-1/2"-8" bore Series Q6 gives you a broad selection to match the proper mount to your application. Eaton offers rigid mounts (including side lug mounts, flange mounts, and extended tie rod mounts) and swivel mounts (including clevis mounts and trunnion mounts). A guide to proper mount selection is provided on pages 8 through 41. For custom mounts, enter "XX" for model code positions 3 and 4, and give a detailed description with drawings. Series Q6 cylinders are available in all mounting styles listed.

Selecting the Proper Mounting

Just as the cylinder bore must be sized to provide the proper force for an application, a cylinder mounting that can absorb these application forces must also be specified. Note: In the mounting information, some mounts have been down-rated to minimize deflection. For applications where the motion is linear and parallel to the cylinder rod motion, a rigid mount is recommended. For curvilinear motion, a swivel mount should be chosen. The specifics of each application dictate the correct mounting style.

**Code AS (MS2)
Side Lug**

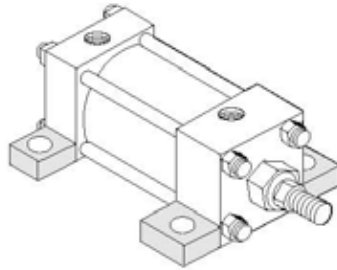

**Code BS (MS4)
Tapped**

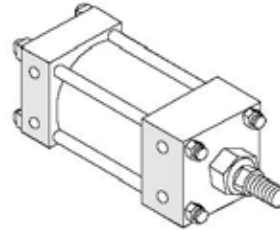

**Code ES (MS7)
End Lug**

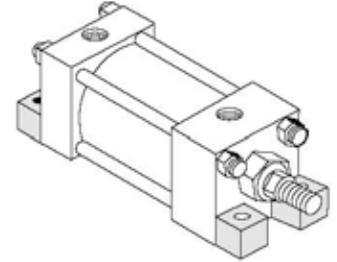

**Code FS (MF1)
Head Rectangular Flange**

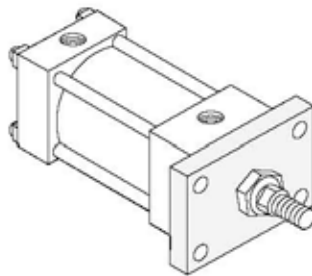

**Code GG (ME3)
Head Square**

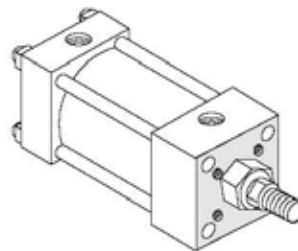

**Code CF (MP1)
Cap Fixed Clevis**

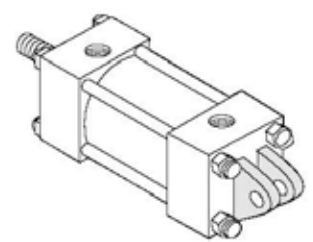

**Code RS (MF2)
Cap Rectangular Flange**

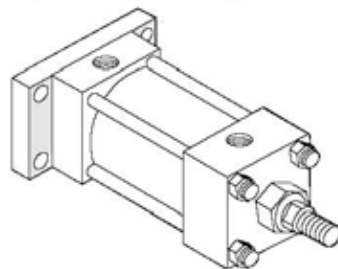

**Code PP (ME4)
Cap Square**

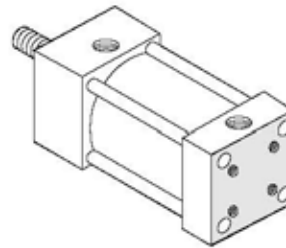

**Code WS (MT2)
Cap Trunnion**

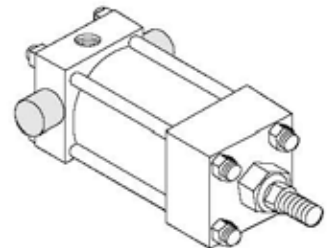

Series Q6/NQ Mounting Style

1-1/2 – 8 inch Bores

**Code US (MT2)
Head Trunnion**

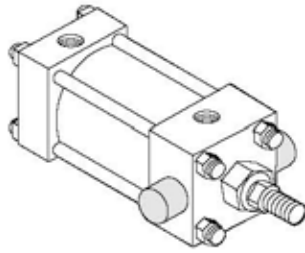

**Code FM Sleeve Nut
Construction for Tapped
Faces**

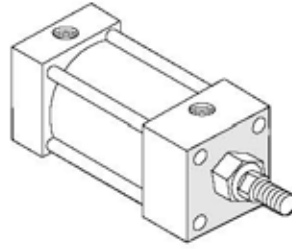

**Codes NS (MX2) Cap, MS
(MX3) head, 23 (MX1)
Extended Tie Rod**

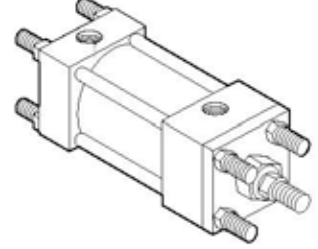

**Code KS (MX0)
No Mounts**

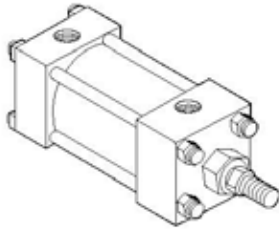

**Double Rod
Code KD (MX0)
No Mounts**

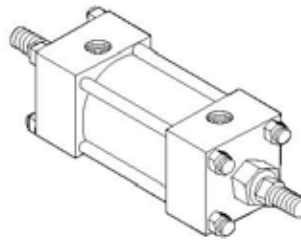

**Code YY (MS1)
Angle**

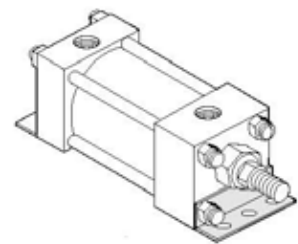

**Code DE (MP4)
Cap Detachable Eye**

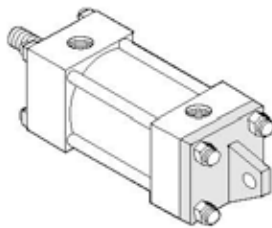

**Code DC (MP2)
Cap Detachable Clevis**

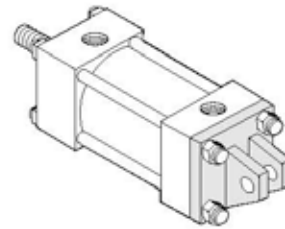

Series Q6/NQ Mounting Style:

3/4 & 1-1/8 inch Bores

Available Mountings

The variety of standard ANSI/NFPA mountings available in 3/4"-1/8" bore Series Q6 gives you a broad selection to match the proper mount to your application. Eaton offers rigid mounts (including side lug mounts, flange mounts, and extended tie rod mounts) and swivel mounts (including clevis mounts and trunnion mounts). A guide to proper mount selection is provided on pages 47 through 54. For custom mounts, enter "XX" for model code positions 3 and 4, and give a detailed description with drawings. Series Q6 cylinders are available in all mounting styles listed.

Selecting the Proper Mounting

Just as the cylinder bore must be sized to provide the proper force for an application, a cylinder mounting that can absorb these application forces must also be specified. Note: In the mounting information, some mounts have been downrated to minimize deflection. For applications where the motion is linear and parallel to the cylinder rod motion, a rigid mount is recommended. For curvilinear motion, a swivel mount should be chosen. The specifics of each application dictate the correct mounting style.

**Code EE (MS8)
Bolt Thru**

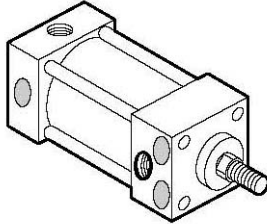

**Code BS(MS9)
Tapped**

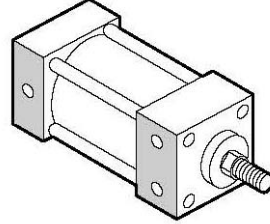

**Code FS (MF1)
Head Rectanular Flange**

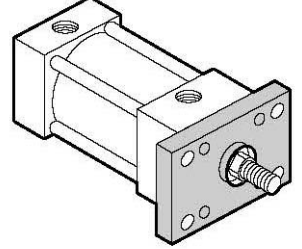

**Code RS (MF2)
Cap Rectangular Flange**

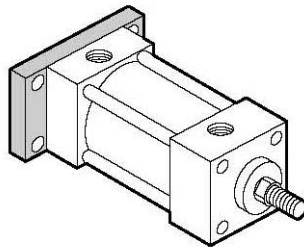

**Code FM (MR1)
Head Tapped Face**

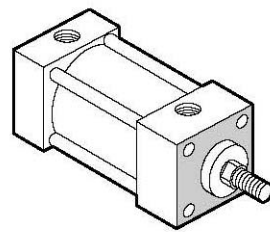

**Code TN (MNR1)
Threaded Nose Mounts**

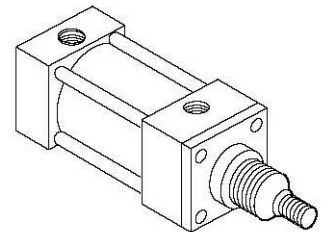

**Code KS (MX0)
No Mounts**

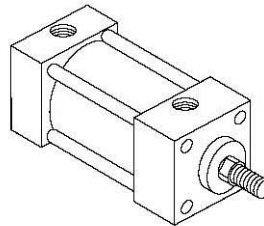

**Code ED Double Rod,
Bolt Thru**

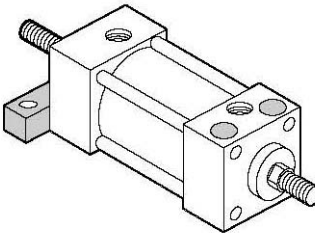

**Code CM (MP3)
Fixed Eye**

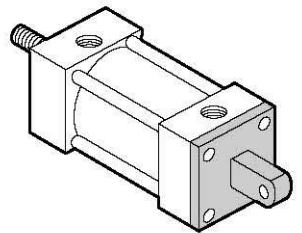

**Code DE (MP4)
Detachable Eye**

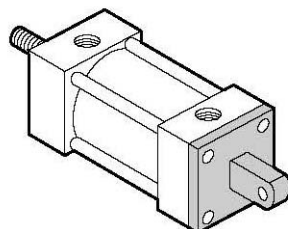

**Code DC (MP2)
Detachable Clevis**

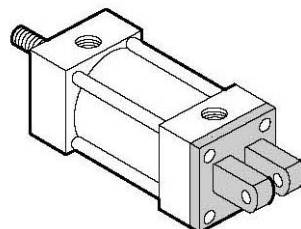

Series Q6/NQ Mounting Styles and Installation Dimensions

Code AS Side Lug Mounts (ANSI MS2)

Side lug mounts are for moving loads along a flat guided surface as in a carriage along rails.

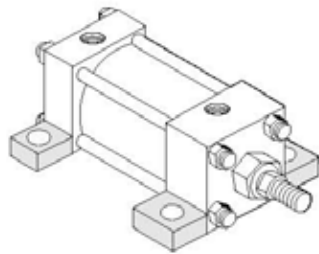

The mounting surface should be flat and parallel to the centerline of the piston rod.

The load should be guided to transverse along the centerline of the piston rod. The frame on which the cylinder is mounted must be sufficiently rigid to resist bending moments.

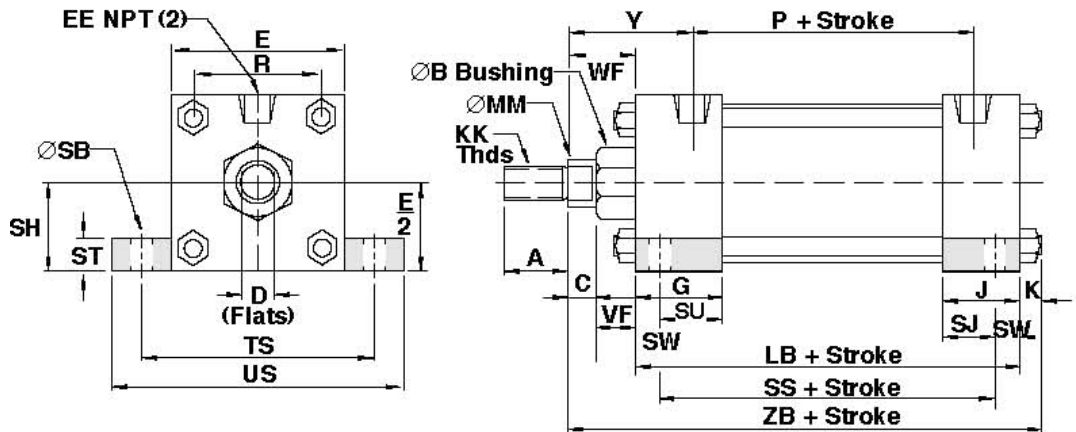

NOTE

Limit operating pressure to 400 psi (27 bar) non-shock hydraulic for minimum deflection. For strokes in excess of 30 inches, see "Stop Tube Selection" on page 45.

With unsupported loads, the bearing must absorb more force. For these applications, the larger available rod is recommended, and stop tubes should be considered.

Series Q6/NQ Mounting Styles and Installation Dimensions

Code AS Side Lug Mounts (ANSI MS2)

DIMENSION		1 1/2" BORE (38.10)		2" BORE (50.80)		2 1/2" BORE (63.50)		3 1/4" BORE (82.55)	
Rod	Std.	5/8"	(15.88)	5/8"	(15.88)	5/8"	(15.88)	1"	(25.40)
	O.S.	1"	(25.40)	1"	(25.40)	1"	(25.40)	1-3/8"	(34.93)
A	Std.	.750	(19.05)	.750	(19.05)	.750	(19.05)	1.125	(28.58)
	O.S.	1.125	(28.58)	1.125	(28.58)	1.125	(28.58)	1.625	(41.28)
B +.000									
	-.002 Std.	1.124	(28.55)	.750	(19.05)	.750	(19.05)	1.125	(28.58)
B +.000									
	-.002 O.S.	1.499	(38.08)	1.125	(28.58)	1.125	(28.58)	1.625	(41.28)
C	Std.	.375	(9.53)	.375	(9.53)	.375	(9.53)	.500	(12.70)
	O.S.	.500	(12.70)	.500	(12.70)	.500	(12.70)	.625	(15.88)
CC	Std.	1/2 - 20		1/2 - 20		1/2 - 20		7/8 - 14	
	O.S.	7/8 - 14		7/8 - 14		7/8 - 14		1-1/4 - 12	
D	Std.	.500	(12.70)	.500	(12.70)	.500	(12.70)	.813	(12.70)
	O.S.	.813	(20.64)	.813	(20.64)	.813	(20.64)	1.125	(28.58)
E		2.000	(50.80)	2.500	(63.50)	3.000	(76.20)	3.750	(95.25)
EE		.375	(9.53)	.375	(9.53)	.375	(9.53)	.500	(12.70)
FF	Std.	5/8 - 18		5/8 - 18		5/8 - 18		1 - 14	
	O.S.	1 - 14		1 - 14		1 - 14		1-3/8 - 12	
G		1.500	(38.10)	1.500	(38.10)	1.500	(38.10)	1.750	(44.45)
J		1.000	(25.40)	1.000	(25.40)	1.000	(25.40)	1.250	(31.75)
K		.250	(6.35)	.313	(7.94)	.313	(7.94)	.375	(9.53)
KK	Std.	7/16 - 20		7/16 - 20		7/16 - 20		3/4 - 16	
	O.S.	3/4 - 16		3/4 - 16		3/4 - 16		1 - 14	
LB		3.625	(92.08)	3.625	(92.08)	3.750	(95.25)	4.250	(107.95)
MM	Std.	.625	(15.88)	.625	(15.88)	.625	(15.88)	1.000	(25.40)
	O.S.	1.000	(25.40)	1.000	(25.40)	1.000	(25.40)	1.375	(34.93)
P		2.313	(58.74)	2.313	(58.74)	2.438	(61.91)	2.625	(66.68)
R		1.428	(36.27)	1.838	(46.68)	2.192	(55.67)	2.758	(70.05)
SB		.438	(11.11)	.438	(11.11)	.438	(11.11)	.563	(14.29)
SH		1.000	(25.40)	1.250	(31.75)	1.500	(38.10)	1.875	(47.63)
SJ		.625	(15.88)	.625	(15.88)	.625	(15.88)	.750	(19.05)
SS		2.875	(73.03)	2.875	(73.03)	3.000	(76.20)	3.250	(82.55)
ST		.500	(12.70)	.500	(12.70)	.500	(12.70)	.750	(19.05)
SU		1.125	(28.58)	1.125	(28.58)	1.125	(28.58)	1.250	(31.75)
SW		.375	(9.53)	.375	(9.53)	.375	(9.53)	.500	(12.70)
TS		2.750	(69.85)	3.250	(82.55)	3.750	(95.25)	4.750	(120.65)
US		3.500	(88.90)	4.000	(101.60)	4.500	(114.30)	5.750	(146.05)
VF	Std.	.625	(15.88)	.625	(15.88)	.625	(15.88)	.875	(22.23)
	O.S.	.875	(22.23)	.875	(22.23)	.875	(22.23)	1.000	(25.40)
WF	Std.	1.000	(25.40)	1.000	(25.40)	1.000	(25.40)	1.375	(34.93)
	O.S.	1.375	(34.93)	1.375	(34.93)	1.375	(34.93)	1.625	(41.28)
XS	Std.	1.375	(34.93)	1.375	(34.93)	1.375	(34.93)	1.875	(47.63)
	O.S.	1.750	(44.45)	1.750	(44.45)	1.750	(44.45)	2.125	(53.98)
Y	Std.	1.875	(47.63)	1.875	(47.63)	1.875	(47.63)	2.438	(61.91)
	O.S.	2.250	(57.15)	2.250	(57.15)	2.250	(57.15)	2.688	(68.26)
ZB	Std.	4.875	(123.83)	4.938	(125.41)	5.063	(128.59)	6.000	(152.40)
	O.S.	5.250	(133.35)	5.313	(134.94)	5.438	(138.11)	6.250	(158.75)

All dimensions in inches (mm)

Series Q6/NQ Mounting Styles and Installation Dimensions

Code AS Side Lug Mounts (ANSI MS2)

4" BORE (101.60)		5" BORE (127.00)		6" BORE (152.40)		7" BORE (177.80)		8" BORE (203.20)	
1"	(25.40)	1"	(25.40)	1-3/8"	(34.93)	1-3/8"	(34.93)	1-3/8"	(34.93)
1-3/8"	(34.93)	1-3/8"	(34.93)	1-3/4"	(44.45)	1-3/4"	(44.45)	1-3/4"	(44.45)
1.125	(28.58)	1.125	(28.58)	1.625	(41.28)	1.625	(41.28)	1.625	(41.28)
1.625	(41.28)	1.625	(41.28)	2.000	(50.80)	2.000	(50.80)	2.000	(50.80)
1.125	(28.58)	1.125	(28.58)	1.625	(41.28)	1.625	(41.28)	1.625	(41.28)
1.625	(41.28)	1.625	(41.28)	2.000	(50.80)	2.000	(50.80)	2.000	(50.80)
.500	(12.70)	.500	(12.70)	.625	(15.88)	.625	(15.88)	.625	(15.88)
.625	(15.88)	.625	(15.88)	.750	(19.05)	.750	(19.05)	.750	(19.05)
7/8 - 14		7/8 - 14		1-1/4 - 12		1-1/4 - 12		1-1/4 - 12	
1-1/4 - 12		1-1/4 - 12		1-1/2 - 12		1-1/2 - 12		1-1/2 - 12	
.813	(12.70)	.813	(12.70)	1.125	(15.88)	1.125	(15.88)	1.125	(15.88)
1.125	(28.58)	1.125	(28.58)	1.500	(38.10)	1.500	(38.10)	1.500	(38.10)
4.500	(114.30)	5.500	(139.70)	6.500	(165.10)	7.500	(190.50)	8.500	(215.90)
.500	(12.70)	.500	(12.70)	.750	(19.05)	.750	(19.05)	.750	(19.05)
1 - 14		1 - 14		1-3/8 - 12		1-3/8 - 12		1-3/8 - 12	
1-3/8 - 12		1-3/8 - 12		1-3/4 - 12		1-3/4 - 12		1-3/4 - 12	
1.750	(44.45)	1.750	(44.45)	2.000	(50.80)	2.000	(50.80)	2.000	(50.80)
1.250	(31.75)	1.250	(31.75)	1.500	(38.10)	1.500	(38.10)	1.500	(38.10)
.375	(9.53)	.438	(11.11)	.438	(11.11)	.563	(14.29)	.563	(14.29)
3/4 - 16		3/4 - 16		1 - 14		1 - 14		1 - 14	
1 - 14		1 - 14		1-1/4 - 12		1-1/4 - 12		1-1/4 - 12	
4.250	(107.95)	4.500	(114.30)	5.000	(127.00)	5.125	(130.18)	5.125	(130.18)
1.000	(25.40)	1.000	(25.40)	1.375	(34.93)	1.375	(34.93)	1.375	(34.93)
1.375	(34.93)	1.375	(34.93)	1.750	(44.45)	1.750	(44.45)	1.750	(44.45)
2.625	(66.68)	2.875	(73.03)	3.125	(79.38)	3.250	(82.55)	3.250	(82.55)
3.323	(84.40)	4.101	(104.16)	4.879	(123.92)	5.639	(145.54)	6.442	(163.63)
.563	(14.29)	.813	(20.64)	.813	(20.64)	.813	(20.64)	.813	(20.64)
2.250	(57.15)	2.750	(69.85)	3.250	(82.55)	3.750	(95.25)	4.250	(107.95)
.750	(19.05)	.813	(20.64)	.813	(20.64)	.813	(20.64)	.813	(20.64)
.750	(19.05)	.813	(20.64)	.813	(20.64)	.813	(20.64)	.813	(20.64)
.750	(19.05)	1.000	(25.40)	1.000	(25.40)	1.000	(25.40)	1.000	(25.40)
1.250	(31.75)	1.063	(26.99)	1.313	(33.34)	1.313	(33.34)	1.313	(33.34)
.500	(12.70)	.688	(17.46)	.688	(17.46)	.688	(17.46)	.688	(17.46)
5.500	(139.70)	6.875	(174.63)	7.875	(200.03)	8.875	(225.43)	9.875	(250.83)
6.500	(165.10)	8.250	(209.55)	9.250	(234.95)	10.250	(260.35)	11.250	(285.75)
.875	(22.23)	.875	(22.23)	1.000	(25.40)	1.000	(25.40)	1.000	(25.40)
1.000	(25.40)	1.000	(25.40)	1.125	(28.58)	1.125	(28.58)	1.125	(28.58)
1.375	(34.93)	1.375	(34.93)	1.625	(41.28)	1.625	(41.28)	1.625	(41.28)
1.625	(41.28)	1.625	(41.28)	1.875	(47.63)	1.875	(47.63)	1.875	(47.63)
1.875	(47.63)	2.062	(52.37)	2.313	(58.74)	2.313	(58.74)	2.313	(58.74)
2.125	(53.98)	2.313	(58.74)	2.562	(65.07)	2.562	(65.07)	2.562	(65.07)
2.438	(61.91)	2.438	(61.91)	2.813	(71.44)	2.813	(71.44)	2.813	(71.44)
2.688	(68.26)	2.688	(68.26)	3.063	(77.79)	3.063	(77.79)	3.063	(77.79)
6.000	(152.40)	6.313	(160.34)	7.063	(179.39)	7.313	(185.74)	7.313	(185.74)
6.250	(158.75)	6.563	(166.69)	7.313	(185.74)	7.563	(192.09)	7.563	(192.09)

All dimensions in inches (mm)

Series Q6/NQ Mounting Styles and Installation Dimensions

Tapped mounts are for moving loads along a flat guided surface as in a carriage along rails. The mounting surface should be flat and parallel to the centerline of the piston rod.

The load should be guided to traverse along the centerline of the piston rod. The frame on which the cylinder is mounted must be sufficiently rigid to resist bending moments.

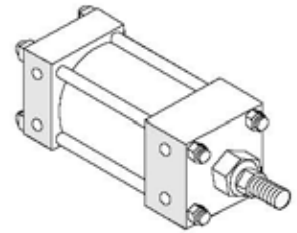

Code BS Tapped Mounts

(ANSI MS4)

DIMENSION		1 1/2" BORE (38.10)		2" BORE (50.80)		2 1/2" BORE (63.50)		3 1/4" BORE (82.55)	
Rod	Std.	5/8"	(15.88)	5/8"	(15.88)	5/8"	(15.88)	1"	(25.40)
	O.S.	1"	(25.40)	1"	(25.40)	1"	(25.40)	1-3/8"	(34.93)
A	Std.	.750	(19.05)	.750	(19.05)	.750	(19.05)	1.125	(28.58)
	O.S.	1.125	(28.58)	1.125	(28.58)	1.125	(28.58)	1.625	(41.28)
B +.000 -.002	Std.	1.124	(28.55)	.750	(19.05)	.750	(19.05)	1.125	(28.58)
	O.S.	1.499	(38.08)	1.125	(28.58)	1.125	(28.58)	1.625	(41.28)
C	Std.	.375	(9.53)	.375	(9.53)	.375	(9.53)	.500	(12.70)
	O.S.	.500	(12.70)	.500	(12.70)	.500	(12.70)	.625	(15.88)
CC	Std.	1/2 - 20		1/2 - 20		1/2 - 20		7/8 - 14	
	O.S.	7/8 - 14		7/8 - 14		7/8 - 14		1-1/4 - 12	
D	Std.	.500	(12.70)	.500	(12.70)	.500	(12.70)	.813	(12.70)
	O.S.	.813	(20.64)	.813	(20.64)	.813	(20.64)	1.125	(28.58)
E		2.000	(50.80)	2.500	(63.50)	3.000	(76.20)	3.750	(95.25)
EE		.375	(9.53)	.375	(9.53)	.375	(9.53)	.500	(12.70)
FF	Std.	5/8 - 18		5/8 - 18		5/8 - 18		1 - 14	
	O.S.	1 - 14		1 - 14		1 - 14		1-3/8 - 12	
G		1.500	(38.10)	1.500	(38.10)	1.500	(38.10)	1.750	(44.45)
J		1.000	(25.40)	1.000	(25.40)	1.000	(25.40)	1.250	(31.75)
K		.250	(6.35)	.313	(7.94)	.313	(7.94)	.375	(9.53)
KK	Std.	7/16 - 20		7/16 - 20		7/16 - 20		3/4 - 16	
	O.S.	3/4 - 16		3/4 - 16		3/4 - 16		1 - 14	
LB		3.625	(92.08)	3.625	(92.08)	3.750	(95.25)	4.250	(107.95)
MM	Std.	.625	(15.88)	.625	(15.88)	.625	(15.88)	1.000	(25.40)
	O.S.	1.000	(25.40)	1.000	(25.40)	1.000	(25.40)	1.375	(34.93)
ND		.375	(9.53)	.375	(9.53)	.500	(12.70)	.750	(19.05)
NT		1/4 - 20		5/16 - 18		3/8 - 18		1/2 - 13	
P		2.313	(58.74)	2.313	(58.74)	2.438	(61.91)	2.625	(66.68)
R		1.428	(36.27)	1.838	(46.68)	2.192	(55.67)	2.758	(70.05)
SN		2.250	(57.15)	2.250	(57.15)	2.375	(60.33)	2.625	(66.68)
TN		.625	(15.88)	.875	(22.23)	1.250	(31.75)	1.500	(38.10)
VF	Std.	.625	(15.88)	.625	(15.88)	.625	(15.88)	.875	(22.23)
	O.S.	.875	(22.23)	.875	(22.23)	.875	(22.23)	1.000	(25.40)
WF	Std.	1.000	(25.40)	1.000	(25.40)	1.000	(25.40)	1.375	(34.93)
	O.S.	1.375	(34.93)	1.375	(34.93)	1.375	(34.93)	1.625	(41.28)
XT	Std.	1.938	(49.21)	1.938	(49.21)	1.938	(49.21)	2.438	(61.91)
	O.S.	2.313	(58.74))	2.313	(58.74))	2.313	(58.74))	2.688	(68.26)
Y	Std.	1.875	(47.63)	1.875	(47.63)	1.875	(47.63)	2.438	(61.91)
	O.S.	2.250	(57.15)	2.250	(57.15)	2.250	(57.15)	2.688	(68.26)
ZB	Std.	4.875	(123.83)	4.938	(125.41)	5.063	(128.59)	6.000	(152.40)
	O.S.	5.250	(133.35)	5.313	(134.94)	5.438	(138.11)	6.250	(158.75)

All dimensions in inches (mm)

Series Q6/NQ Mounting Styles and Installation Dimensions

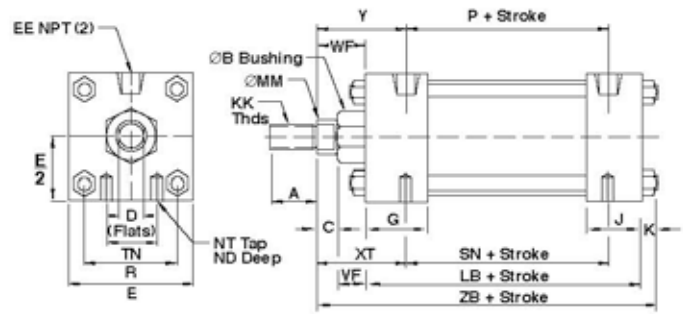

Code BS Tapped Mounts

(ANSI MS4)

4" BORE (101.60)		5" BORE (127.00)		6" BORE (152.40)		7" BORE (177.80)		8" BORE (203.20)	
1"	(25.40)	1"	(25.40)	1-3/8"	(34.93)	1-3/8"	(34.93)	1-3/8"	(34.93)
1-3/8"	(34.93)	1-3/8"	(34.93)	1-3/4"	(44.45)	1-3/4"	(44.45)	1-3/4"	(44.45)
1.125	(28.58)	1.125	(28.58)	1.625	(41.28)	1.625	(41.28)	1.625	(41.28)
1.625	(41.28)	1.625	(41.28)	2.000	(50.80)	2.000	(50.80)	2.000	(50.80)
1.125	(28.58)	1.125	(28.58)	1.625	(41.28)	1.625	(41.28)	1.625	(41.28)
1.625	(41.28)	1.625	(41.28)	2.000	(50.80)	2.000	(50.80)	2.000	(50.80)
.500	(12.70)	.500	(12.70)	.625	(15.88)	.625	(15.88)	.625	(15.88)
.625	(15.88)	.625	(15.88)	.750	(19.05)	.750	(19.05)	.750	(19.05)
7/8 - 14		7/8 - 14		1-1/4 - 12		1-1/4 - 12		1-1/4 - 12	
1-1/4 - 12		1-1/4 - 12		1-1/2 - 12		1-1/2 - 12		1-1/2 - 12	
.813	(12.70)	.813	(12.70)	1.125	(15.88)	1.125	(15.88)	1.125	(15.88)
1.125	(28.58)	1.125	(28.58)	1.500	(38.10)	1.500	(38.10)	1.500	(38.10)
4.500	(114.30)	5.500	(139.70)	6.500	(165.10)	7.500	(190.50)	8.500	(215.90)
.500	(12.70)	.500	(12.70)	.750	(19.05)	.750	(19.05)	.750	(19.05)
1 - 14		1 - 14		1-3/8 - 12		1-3/8 - 12		1-3/8 - 12	
1-3/8 - 12		1-3/8 - 12		1-3/4 - 12		1-3/4 - 12		1-3/4 - 12	
1.750	(44.45)	1.750	(44.45)	2.000	(50.80)	2.000	(50.80)	2.000	(50.80)
1.250	(31.75)	1.250	(31.75)	1.500	(38.10)	1.500	(38.10)	1.500	(38.10)
.375	(9.53)	.438	(11.11)	.438	(11.11)	.563	(14.29)	.563	(14.29)
3/4 - 16		3/4 - 16		1 - 14		1 - 14		1 - 14	
1 - 14		1 - 14		1-1/4 - 12		1-1/4 - 12		1-1/4 - 12	
4.250	(107.95)	4.500	(114.30)	5.000	(127.00)	5.125	(130.18)	5.125	(130.18)
1.000	(25.40)	1.000	(25.40)	1.375	(34.93)	1.375	(34.93)	1.375	(34.93)
1.375	(34.93)	1.375	(34.93)	1.750	(44.45)	1.750	(44.45)	1.750	(44.45)
.750	(19.05)	.938	(23.81)	1.125	(28.58)	1.125	(28.58)	1.125	(28.58)
1/2 - 13		5/8 - 11		3/4 - 10		3/4 - 10		3/4 - 10	
2.625	(66.68)	2.875	(73.03)	3.125	(79.38)	3.250	(82.55)	3.250	(82.55)
3.323	(84.40)	4.101	(104.16)	4.879	(123.92)	5.639	(145.54)	6.442	(163.63)
2.625	(66.68)	2.875	(73.03)	3.125	(79.38)	3.250	(82.55)	3.250	(82.55)
2.063	(52.37)	2.688	(68.28)	3.250	(82.55)	3.500	(88.90)	4.500	(114.30)
.875	(22.23)	.875	(22.23)	1.000	(25.40)	1.000	(25.40)	1.000	(25.40)
1.000	(25.40)	1.000	(25.40)	1.125	(28.58)	1.125	(28.58)	1.125	(28.58)
1.375	(34.93)	1.375	(34.93)	1.625	(41.28)	1.625	(41.28)	1.625	(41.28)
1.625	(41.28)	1.625	(41.28)	1.875	(47.63)	1.875	(47.63)	1.875	(47.63)
2.438	(61.91)	2.438	(61.91)	2.813	(71.44)	2.813	(71.44)	2.813	(71.44)
2.688	(68.26)	2.688	(68.26)	3.063	(77.79)	3.063	(77.79)	3.063	(77.79)
2.438	(61.91)	2.438	(61.91)	2.813	(71.44)	2.813	(71.44)	2.813	(71.44)
2.688	(68.26)	2.688	(68.26)	3.063	(77.79)	3.063	(77.79)	3.063	(77.79)
6.000	(152.40)	6.313	(160.34)	7.063	(179.39)	7.313	(185.74)	7.313	(185.74)
6.250	(158.75)	6.563	(166.69)	7.313	(185.74)	7.563	(192.09)	7.563	(192.09)

All dimensions in inches (mm)

NOTE

For strokes in excess of 30 inches, see "Stop Tube Selection" on page 45.

With unsupported loads, the bearing must absorb more force. For these applications, the larger available rod is recommended, and stop tubes should be considered.

Series Q6/NQ Mounting Styles and Installation Dimensions

End lug mounts are for moving loads along a flat guided surface as in a carriage along rails. The mounting surface should be flat and parallel to the centerline of the piston rod.

The load should be guided to traverse along the centerline of the piston rod. The frame on which the cylinder is mounted must be sufficiently rigid to resist bending moments.

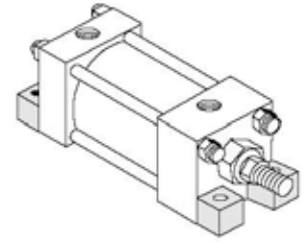

Code ES End Lug Mounts

(ANSI MS7)

DIMENSION		1 1/2" BORE (38.10)		2" BORE (50.80)		2 1/2" BORE (63.50)		3 1/4" BORE (82.55)	
Rod	Std.	5/8"	(15.88)	5/8"	(15.88)	5/8"	(15.88)	1"	(25.40)
	O.S.	1"	(25.40)	1"	(25.40)	1"	(25.40)	1-3/8"	(34.93)
A	Std.	.750	(19.05)	.750	(19.05)	.750	(19.05)	1.125	(28.58)
	O.S.	1.125	(28.58)	1.125	(28.58)	1.125	(28.58)	1.625	(41.28)
B +.000									
	-.002	Std.	1.124	(28.55)	.750	(19.05)	.750	(19.05)	1.125
+.000									
	-.002	O.S.	1.499	(38.08)	1.125	(28.58)	1.125	(28.58)	1.625
C	Std.	.375	(9.53)	.375	(9.53)	.375	(9.53)	.500	(12.70)
	O.S.	.500	(12.70)	.500	(12.70)	.500	(12.70)	.625	(15.88)
CC	Std.	1/2 - 20		1/2 - 20		1/2 - 20		7/8 - 14	
	O.S.	7/8 - 14		7/8 - 14		7/8 - 14		1-1/4 - 12	
D	Std.	.500	(12.70)	.500	(12.70)	.500	(12.70)	.813	(12.70)
	O.S.	.813	(20.64)	.813	(20.64)	.813	(20.64)	1.125	(28.58)
E		2.000	(50.80)	2.500	(63.50)	3.000	(76.20)	3.750	(95.25)
EB		.313	(7.94)	.375	(9.53)	.375	(9.53)	.438	(11.11)
EE		.375	(9.53)	.375	(9.53)	.375	(9.53)	.500	(12.70)
EF		1.125	(28.58)	1.313	(33.34)	1.438	(36.51)	1.500	(38.10)
EL		.750	(19.05)	.938	(23.81)	1.063	(26.99)	.875	(22.23)
EO		.250	(6.35)	.313	(7.94)	.313	(7.94)	.375	(9.53)
ET		.500	(12.70)	.750	(19.05)	.750	(19.05)	1.000	(25.40)
FF	Std.	5/8 - 18		5/8 - 18		5/8 - 18		1 - 14	
	O.S.	1 - 14		1 - 14		1 - 14		1-3/8 - 12	
G		1.500	(38.10)	1.500	(38.10)	1.500	(38.10)	1.750	(44.45)
J		1.000	(25.40)	1.000	(25.40)	1.000	(25.40)	1.250	(31.75)
KK	Std.	7/16 - 20		7/16 - 20		7/16 - 20		3/4 - 16	
	O.S.	3/4 - 16		3/4 - 16		3/4 - 16		1 - 14	
LB		3.625	(92.08)	3.625	(92.08)	3.750	(95.25)	4.250	(107.95)
MM	Std.	.625	(15.88)	.625	(15.88)	.625	(15.88)	1.000	(25.40)
	O.S.	1.000	(25.40)	1.000	(25.40)	1.000	(25.40)	1.375	(34.93)
P		2.313	(58.74)	2.313	(58.74)	2.438	(61.91)	2.625	(66.68)
R		1.428	(36.27)	1.838	(46.68)	2.192	(55.67)	2.758	(70.05)
SE		5.500	(139.70)	5.875	(149.23)	6.250	(158.75)	6.625	(168.28)
VF	Std.	.625	(15.88)	.625	(15.88)	.625	(15.88)	.875	(22.23)
	O.S.	.875	(22.23)	.875	(22.23)	.875	(22.23)	1.000	(25.40)
WF	Std.	1.000	(25.40)	1.000	(25.40)	1.000	(25.40)	1.375	(34.93)
	O.S.	1.375	(34.93)	1.375	(34.93)	1.375	(34.93)	1.625	(41.28)
XE	Std.	5.375	(136.53)	5.563	(141.29)	5.813	(147.64)	6.500	(165.10)
	O.S.	5.750	(146.05)	5.938	(150.81)	6.188	(157.16)	6.750	(171.45)
Y	Std.	1.875	(47.63)	1.875	(47.63)	1.875	(47.63)	2.438	(61.91)
	O.S.	2.250	(57.15)	2.250	(57.15)	2.250	(57.15)	2.688	(68.26)
ZE	Std.	5.625	(142.88)	5.875	(149.23)	6.125	(155.58)	6.875	(174.63)
	O.S.	6.000	(152.40)	6.250	(158.75)	6.500	(165.10)	7.125	(180.98)

All dimensions in inches (mm)

Series Q6/NQ Mounting Styles and Installation Dimensions

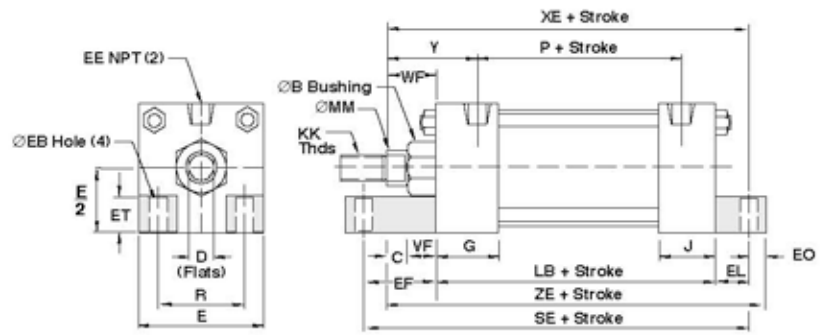

Code ES End Lug Mounts

(ANSI MS7)

4" BORE (101.60)		5" BORE (127.00)		6" BORE (152.40)		7" BORE (177.80)		8" BORE (203.20)	
1"	(25.40)	1"	(25.40)	1-3/8"	(34.93)	1-3/8"	(34.93)	1-3/8"	(34.93)
1-3/8"	(34.93)	1-3/8"	(34.93)	1-3/4"	(44.45)	1-3/4"	(44.45)	1-3/4"	(44.45)
1.125	(28.58)	1.125	(28.58)	1.625	(41.28)	1.625	(41.28)	1.625	(41.28)
1.625	(41.28)	1.625	(41.28)	2.000	(50.80)	2.000	(50.80)	2.000	(50.80)
1.125	(28.58)	1.125	(28.58)	1.625	(41.28)	1.625	(41.28)	1.625	(41.28)
1.625	(41.28)	1.625	(41.28)	2.000	(50.80)	2.000	(50.80)	2.000	(50.80)
.500	(12.70)	.500	(12.70)	.625	(15.88)	.625	(15.88)	.625	(15.88)
.625	(15.88)	.625	(15.88)	.750	(19.05)	.750	(19.05)	.750	(19.05)
7/8 - 14		7/8 - 14		1-1/4 - 12		1-1/4 - 12		1-1/4 - 12	
1-1/4 - 12		1-1/4 - 12		1-1/2 - 12		1-1/2 - 12		1-1/2 - 12	
.813	(12.70)	.813	(12.70)	1.125	(15.88)	1.125	(15.88)	1.125	(15.88)
1.125	(28.58)	1.125	(28.58)	1.500	(38.10)	1.500	(38.10)	1.500	(38.10)
4.500	(114.30)	5.500	(139.70)	6.500	(165.10)	7.500	(190.50)	8.500	(215.90)
.438	(11.11)	.563	(14.29)	.563	(14.29)	.688	(17.46)	.688	(17.46)
.500	(12.70)	.500	(12.70)	.750	(19.05)	.750	(19.05)	.750	(19.05)
1.625	(41.28)	1.688	(42.88)	1.750	(44.45)	1.750	(44.45)	1.750	(44.45)
1.000	(25.40)	1.063	(26.99)	1.000	(25.40)	1.125	(28.58)	1.125	(28.58)
.375	(9.53)	.500	(12.70)	.500	(12.70)	.625	(15.88)	.625	(15.88)
1.250	(31.75)	1.500	(38.10)	1.500	(38.10)	1.750	(44.45)	2.063	(52.39)
1 - 14		1 - 14		1-3/8 - 12		1-3/8 - 12		1-3/8 - 12	
1-3/8 - 12		1-3/8 - 12		1-3/4 - 12		1-3/4 - 12		1-3/4 - 12	
1.750	(44.45)	1.750	(44.45)	2.000	(50.80)	2.000	(50.80)	2.000	(50.80)
1.250	(31.75)	1.250	(31.75)	1.500	(38.10)	1.500	(38.10)	1.500	(38.10)
3/4 - 16		3/4 - 16		1 - 14		1 - 14		1 - 14	
1 - 14		1 - 14		1-1/4 - 12		1-1/4 - 12		1-1/4 - 12	
4.250	(107.95)	4.500	(114.30)	5.000	(127.00)	5.125	(130.18)	5.125	(130.18)
1.000	(25.40)	1.000	(25.40)	1.375	(34.93)	1.375	(34.93)	1.375	(34.93)
1.375	(34.93)	1.375	(34.93)	1.750	(44.45)	1.750	(44.45)	1.750	(44.45)
2.625	(66.68)	2.875	(73.03)	3.125	(79.38)	3.250	(82.55)	3.250	(82.55)
3.323	(84.40)	4.101	(104.16)	4.879	(123.92)	5.639	(145.54)	6.442	(163.63)
6.875	(174.63)	7.250	(184.15)	7.750	(196.85)	8.000	(203.20)	8.000	(203.20)
.875	(22.23)	.875	(22.23)	1.000	(25.40)	1.000	(25.40)	1.000	(25.40)
1.000	(25.40)	1.000	(25.40)	1.125	(28.58)	1.125	(28.58)	1.125	(28.58)
1.375	(34.93)	1.375	(34.93)	1.625	(41.28)	1.625	(41.28)	1.625	(41.28)
1.625	(41.28)	1.625	(41.28)	1.875	(47.63)	1.875	(47.63)	1.875	(47.63)
6.625	(168.28)	6.938	(176.21)	7.625	(193.68)	7.875	(200.03)	7.875	(200.03)
6.875	(174.63)	7.188	(182.56)	7.875	(200.03)	8.125	(206.38)	8.125	(206.38)
2.438	(61.91)	2.438	(61.91)	2.813	(71.44)	2.813	(71.44)	2.813	(71.44)
2.688	(68.26)	2.688	(68.26)	3.063	(77.79)	3.063	(77.79)	3.063	(77.79)
7.000	(177.80)	7.438	(188.91)	8.125	(206.38)	8.500	(215.90)	8.500	(215.90)
7.250	(184.15)	7.688	(195.26)	8.375	(212.73)	8.750	(222.25)	8.750	(222.25)

All dimensions in inches (mm)

NOTE

Limit operating pressure to 400 psi (27 bar) non-shock hydraulic for minimum deflection.

For strokes in excess of 30 inches, see "Stop Tube Selection" on page 45.

With unsupported loads, the bearing must absorb more force. For these applications, the larger available rod is recommended, and stop tubes should be considered.

Series Q6/NQ Mounting Styles and Installation Dimensions

These mounts are ideal for straight line force transfer applications in which the cylinder is used in tension (pulling). The mounting surface should be flat and the rod end cartridge should be piloted into it.

The frame on which the cylinder is mounted must be sufficiently rigid to resist bending moments.

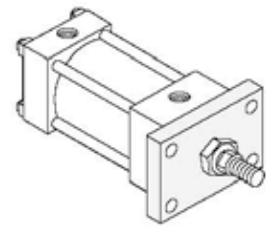

Code FS Head Rectangular Flange Mounts (ANSI MF1)

DIMENSION		1 1/2" BORE (38.10)		2" BORE (50.80)		2 1/2" BORE (63.50)		3 1/4" BORE (82.55)	
Rod	Std.	5/8"	(15.88)	5/8"	(15.88)	5/8"	(15.88)	1"	(25.40)
	O.S.	1"	(25.40)	1"	(25.40)	1"	(25.40)	1-3/8"	(34.93)
A	Std.	.750	(19.05)	.750	(19.05)	.750	(19.05)	1.125	(28.58)
	O.S.	1.125	(28.58)	1.125	(28.58)	1.125	(28.58)	1.625	(41.28)
B +.000 -.002	Std.	1.124	(28.55)	.750	(19.05)	.750	(19.05)	1.125	(28.58)
	O.S.	1.499	(38.08)	1.125	(28.58)	1.125	(28.58)	1.625	(41.28)
C	Std.	.375	(9.53)	.375	(9.53)	.375	(9.53)	.500	(12.70)
	O.S.	.500	(12.70)	.500	(12.70)	.500	(12.70)	.625	(15.88)
CC	Std.	1/2 - 20		1/2 - 20		1/2 - 20		7/8 - 14	
	O.S.	7/8 - 14		7/8 - 14		7/8 - 14		1-1/4 - 12	
D	Std.	.500	(12.70)	.500	(12.70)	.500	(12.70)	.813	(12.70)
	O.S.	.813	(20.64)	.813	(20.64)	.813	(20.64)	1.125	(28.58)
E		2.000	(50.80)	2.500	(63.50)	3.000	(76.20)	3.750	(95.25)
EE		.375	(9.53)	.375	(9.53)	.375	(9.53)	.500	(12.70)
F		.375	(9.53)	.375	(9.53)	.375	(9.53)	.500	(12.70)
FB		.375	(9.53)	.375	(9.53)	.375	(9.53)	.500	(12.70)
FF	Std.	5/8 - 18	5/8 - 18	5/8 - 18	1 - 14	1 - 14	1 - 14	1-3/8 - 12	
	O.S.	1 - 14	1 - 14	1 - 14	1-3/8 - 12	1-3/8 - 12	1-3/8 - 12	1-3/4 - 12	
G		1.500	(38.10)	1.500	(38.10)	1.500	(38.10)	1.750	(44.45)
J		1.000	(25.40)	1.000	(25.40)	1.000	(25.40)	1.250	(31.75)
K		.250	(6.35)	.313	(7.94)	.313	(7.94)	.375	(9.53)
KK	Std.	7/16 - 20		7/16 - 20		7/16 - 20		3/4 - 16	
	O.S.	3/4 - 16		3/4 - 16		3/4 - 16		1 - 14	
LB		3.625	(92.08)	3.625	(92.08)	3.750	(95.25)	4.250	(107.95)
MM	Std.	.625	(15.88)	.625	(15.88)	.625	(15.88)	1.000	(25.40)
	O.S.	1.000	(25.40)	1.000	(25.40)	1.000	(25.40)	1.375	(34.93)
P		2.313	(58.74)	2.313	(58.74)	2.438	(61.91)	2.625	(66.68)
R		1.428	(36.27)	1.838	(46.68)	2.192	(55.67)	2.758	(70.05)
TF		2.750	(69.85)	3.375	(85.73)	3.875	(98.43)	4.688	(119.06)
UF		3.375	(85.73)	4.125	(104.78)	4.625	(117.48)	5.500	(139.70)
V	Std.	.250	(6.35)	.250	(6.35)	.250	(6.35)	.250	(6.35)
	O.S.	.500	(12.70)	.500	(12.70)	.500	(12.70)	.375	(9.53)
W	Std.	.625	(15.88)	.625	(15.88)	.625	(15.88)	.750	(19.05)
	O.S.	1.000	(25.40)	1.000	(25.40)	1.000	(25.40)	1.000	(25.40)
WF	Std.	1.000	(25.40)	1.000	(25.40)	1.000	(25.40)	1.375	(34.93)
	O.S.	1.375	(34.93)	1.375	(34.93)	1.375	(34.93)	1.625	(41.28)
Y	Std.	1.875	(47.63)	1.875	(47.63)	1.875	(47.63)	2.438	(61.91)
	O.S.	2.250	(57.15)	2.250	(57.15)	2.250	(57.15)	2.688	(68.26)
ZB	Std.	4.875	(123.83)	4.938	(125.41)	5.063	(128.59)	6.000	(152.40)
	O.S.	5.250	(133.35)	5.313	(134.94)	5.438	(138.11)	6.250	(158.75)

All dimensions in inches (mm)

Series Q6/NQ Mounting Styles and Installation Dimensions

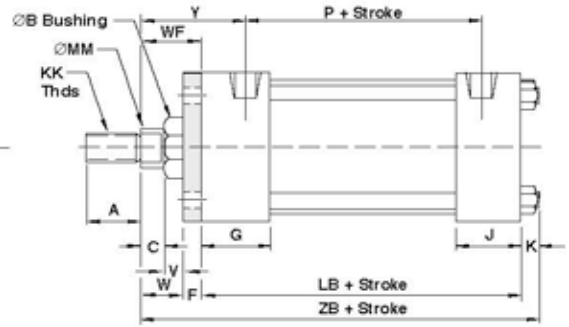
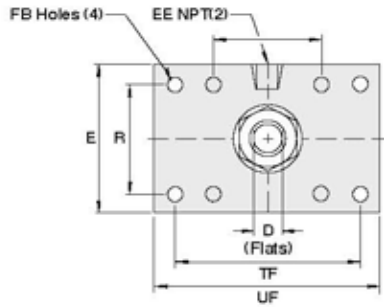

Code FS Head Rectangular Flange Mounts (ANSI MF1)

4" BORE (101.60)		5" BORE (127.00)		6" BORE (152.40)	
1"	(25.40)	1"	(25.40)	1-3/8"	(34.93)
1-3/8"	(34.93)	1-3/8"	(34.93)	1-3/4"	(44.45)
1.125	(28.58)	1.125	(28.58)	1.625	(41.28)
1.625	(41.28)	1.625	(41.28)	2.000	(50.80)
1.125	(28.58)	1.125	(28.58)	1.625	(41.28)
1.625	(41.28)	1.625	(41.28)	2.000	(50.80)
.500	(12.70)	.500	(12.70)	.625	(15.88)
.625	(15.88)	.625	(15.88)	.750	(19.05)
7/8 - 14		7/8 - 14		1-1/4 - 12	
1-1/4 - 12		1-1/4 - 12		1-1/2 - 12	
.813	(12.70)	.813	(12.70)	1.125	(15.88)
1.125	(28.58)	1.125	(28.58)	1.500	(38.10)
4.500	(114.30)	5.500	(139.70)	6.500	(165.10)
.500	(12.70)	.500	(12.70)	.750	(19.05)
.500	(12.70)	.500	(12.70)	.750	(19.05)
.500	(12.70)	.500	(12.70)	.750	(19.05)
1.750	(44.45)	1.750	(44.45)	2.000	(50.80)
1.250	(31.75)	1.250	(31.75)	1.500	(38.10)
.438	(11.11)	.438	(11.11)	1.500	(38.10)
3/4 - 16		3/4 - 16		1 - 14	
1 - 14		1 - 14		1-1/4 - 12	
4.250	(107.95)	4.500	(114.30)	5.000	(127.00)
1.000	(25.40)	1.000	(25.40)	1.375	(34.93)
1.375	(34.93)	1.375	(34.93)	1.750	(44.45)
2.625	(66.68)	2.875	(73.03)	3.125	(79.38)
3.323	(84.40)	4.101	(104.16)	4.879	(123.92)
5.438	(138.11)	6.625	(168.28)	7.625	(193.68)
6.250	(158.75)	7.625	(193.68)	8.625	(219.08)
.250	(6.35)	.250	(6.35)	.250	(6.35)
.375	(9.53)	.375	(9.53)	.375	(9.53)
.750	(19.05)	.750	(19.05)	.875	(22.23)
1.000	(25.40)	1.000	(25.40)	1.125	(28.58)
1.375	(34.93)	1.375	(34.93)	1.625	(41.28)
1.625	(41.28)	1.625	(41.28)	1.875	(47.63)
2.438	(61.91)	2.438	(61.91)	2.813	(71.44)
2.688	(68.26)	2.688	(68.26)	3.063	(77.79)
6.000	(152.40)	6.313	(160.34)	7.063	(179.39)
6.250	(158.75)	6.563	(166.69)	7.313	(185.74)

All dimensions in inches (mm)

NOTE

For strokes in excess of 30 inches, see "Stop Tube Selection" on page 45.

The force of the load should be perpendicular to the mounting surface and parallel to the centerline of the piston rod. For eccentric loads, the larger of the two available rods in each bore size is recommended. Stop tubes should also be considered.

Series Q6/NQ Mounting Styles and Installation Dimensions

These mounts are ideal for straight line force transfer applications in which the cylinder is used in tension (pulling).

The mounting surface should be flat, and the rod end

cartridge should be piloted into it.

The frame on which the cylinder is mounted must be sufficiently rigid to resist bending moments.

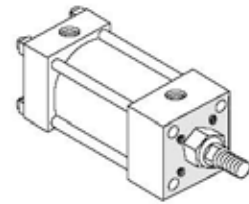

Code GG Head Square

Mounts (ANSI ME3)

DIMENSION		7" BORE (177.80)		8" BORE (203.20)	
Rod	Std.	1-3/8"	(34.93)	1-3/8"	(34.93)
	O.S.	1-3/4"	(44.45)	1-3/4"	(44.45)
A	Std.	1.625	(41.28)	1.625	(41.28)
	O.S.	2.000	(50.80)	2.000	(50.80)
B +.000 -.002	Std.	1.625	(41.28)	1.625	(41.28)
	O.S.	2.000	(50.80)	2.000	(50.80)
C	Std.	.625	(15.88)	.625	(15.88)
	O.S.	.750	(19.05)	.750	(19.05)
CC	Std.	1-1/4 - 12		1-1/4 - 12	
	O.S.	1-1/2 - 12		1-1/2 - 12	
D	Std.	1.125	(15.88)	1.125	(15.88)
	O.S.	1.500	(38.10)	1.500	(38.10)
E		7.500	(190.50)	8.500	(215.90)
EB		.688	(17.46)	.688	(17.46)
EE		.750	(19.05)	.750	(19.05)
FF	Std.	1-3/8 - 12		1-3/8 - 12	
	O.S.	1-3/4 - 12		1-3/4 - 12	
G		2.000	(50.80)	2.000	(50.80)
J		1.500	(38.10)	1.500	(38.10)
K		.563	(14.29)	.563	(14.29)
KK	Std.	1 - 14		1 - 14	
	O.S.	1-1/4 - 12		1-1/4 - 12	
LB		5.125	(130.18)	5.125	(130.18)
MM	Std.	1.375	(34.93)	1.375	(34.93)
	O.S.	1.750	(44.45)	1.750	(44.45)
P		3.250	(82.55)	3.250	(82.55)
R		5.639	(145.54)	6.442	(163.63)
TE		6.750	(171.45)	7.570	(192.27)
VF	Std.	1.000	(25.40)	1.000	(25.40)
	O.S.	1.125	(28.58)	1.125	(28.58)
Y	Std.	2.813	(71.44)	2.813	(71.44)
	O.S.	3.063	(77.79)	3.063	(77.79)
ZB	Std.	7.313	(185.74)	7.313	(185.74)
	O.S.	7.563	(192.09)	7.563	(192.09)

All dimensions in inches (mm)

NOTE

For strokes in excess of 30 inches, see "Stop Tube Selection" on page 45.

The force of the load should be perpendicular to the mounting surface and parallel to the centerline of the piston rod. For eccentric loads, the larger of the two available rods in each bore size is recommended. Stop tubes should also be considered.

Series Q6/NQ Mounting Styles and Installation Dimensions

Code GG Head Square Mounts (ANSI ME3)

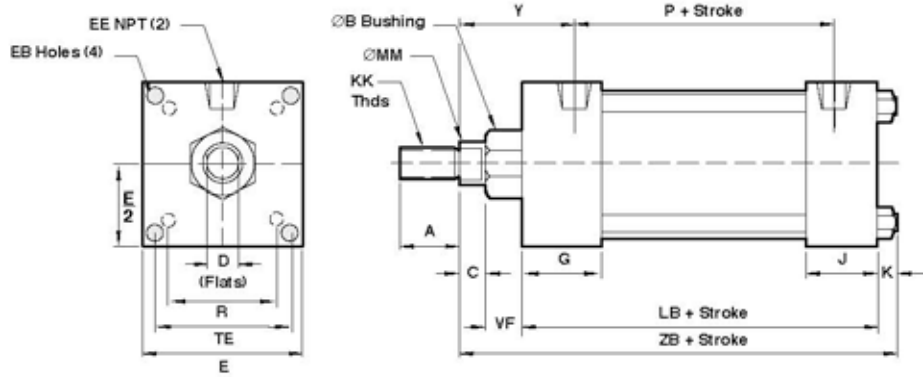

Series Q6/NQ Mounting Styles and Installation Dimensions

These mounts can be used both in compression (push) and tension (pull). Care must be exercised to prevent rod buckling in compression applications with long strokes.

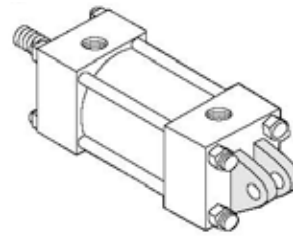

Code CF Fixed Clevis

(MP1)

DIMENSION		1 1/2" BORE (38.10)		2" BORE (50.80)		2 1/2" BORE (63.50)		3 1/4" BORE (82.55)	
Rod	Std.	5/8"	(15.88)	5/8"	(15.88)	5/8"	(15.88)	1"	(25.40)
	O.S.	1"	(25.40)	1"	(25.40)	1"	(25.40)	1-3/8"	(34.93)
A	Std.	.750	(19.05)	.750	(19.05)	.750	(19.05)	1.125	(28.58)
	O.S.	1.125	(28.58)	1.125	(28.58)	1.125	(28.58)	1.625	(41.28)
B +.000 -.002	Std.	1.124	(28.55)	1.124	(28.55)	1.124	(28.55)	1.499	(38.08)
	O.S.	1.499	(38.08)	1.499	(38.08)	1.499	(38.08)	1.999	(50.78)
C	Std.	.375	(9.53)	.375	(9.53)	.375	(9.53)	.500	(12.70)
	O.S.	.500	(12.70)	.500	(12.70)	.500	(12.70)	.625	(15.88)
CB		.750	(19.05)	.750	(19.05)	.750	(19.05)	1.250	(31.75)
CC	Std.	1/2 - 20		1/2 - 20		1/2 - 20		7/8 - 14	
	O.S.	7/8 - 14		7/8 - 14		7/8 - 14		1-1/4 - 12	
CD		.500	(12.70)	.500	(12.70)	.500	(12.70)	.750	(19.05)
CW		.500	(12.70)	.500	(12.70)	.500	(12.70)	.625	(15.88)
D	Std.	.500	(12.70)	.500	(12.70)	.500	(12.70)	.813	(12.70)
	O.S.	.813	(20.64)	.813	(20.64)	.813	(20.64)	1.125	(28.58)
E		2.000	(50.80)	2.500	(63.50)	3.000	(76.20)	3.750	(95.25)
EE		.375	(9.53)	.375	(9.53)	.375	(9.53)	.500	(12.70)
FF	Std.	5/8 - 18		5/8 - 18		5/8 - 18		1 - 14	
	O.S.	1 - 14		1 - 14		1 - 14		1-3/8 - 12	
G		1.500	(38.10)	1.500	(38.10)	1.500	(38.10)	1.750	(44.45)
J		1.000	(25.40)	1.000	(25.40)	1.000	(25.40)	1.250	(31.75)
KK	Std.	7/16 - 20		7/16 - 20		7/16 - 20		3/4 - 16	
	O.S.	3/4 - 16		3/4 - 16		3/4 - 16		1 - 14	
L		.750	(19.05)	.750	(19.05)	.750	(19.05)	1.250	(31.75)
LB		3.625	(92.08)	3.625	(92.08)	3.750	(95.25)	4.250	(107.95)
LR		.750	(19.05)	.750	(19.05)	.750	(19.05)	1.250	(31.75)
M		.500	(12.70)	.500	(12.70)	.500	(12.70)	.750	(19.05)
MM	Std.	.625	(15.88)	.625	(15.88)	.625	(15.88)	1.000	(25.40)
	O.S.	1.000	(25.40)	1.000	(25.40)	1.000	(25.40)	1.375	(34.93)
MR		.625	(15.88)	.625	(15.88)	.625	(15.88)	.938	(23.81)
P		2.313	(58.74)	2.313	(58.74)	2.438	(61.91)	2.625	(66.68)
VF	Std.	.625	(15.88)	.625	(15.88)	.625	(15.88)	.875	(22.23)
	O.S.	.875	(22.23)	.875	(22.23)	.875	(22.23)	1.000	(25.40)
WF	Std.	1.000	(25.40)	1.000	(25.40)	1.000	(25.40)	1.375	(34.93)
	O.S.	1.375	(34.93)	1.375	(34.93)	1.375	(34.93)	1.625	(41.28)
XC	Std.	5.375	(136.53)	5.375	(136.53)	5.500	(139.70)	6.875	(174.63)
	O.S.	5.750	(146.05)	5.750	(146.05)	5.875	(149.23)	7.125	(180.98)
Y	Std.	1.875	(47.63)	1.875	(47.63)	1.875	(47.63)	2.438	(61.91)
	O.S.	2.250	(57.15)	2.250	(57.15)	2.250	(57.15)	2.688	(68.26)

All dimensions in inches (mm)

Series Q6/NQ Mounting Styles and Installation Dimensions

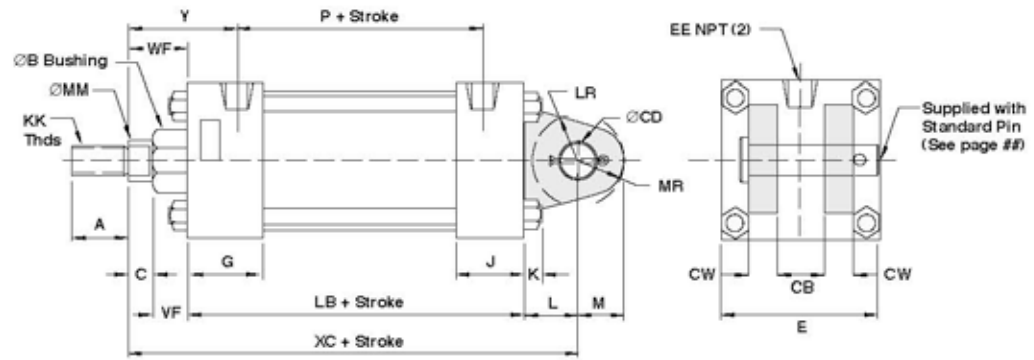

Code CF Fixed Clevis

(MP1)

4" BORE (101.60)		5" BORE (127.00)		6" BORE (152.40)		7" BORE (177.80)		8" BORE (203.20)	
1"	(25.40)	1"	(25.40)	1-3/8"	(34.93)	1-3/8"	(34.93)	1-3/8"	(34.93)
1-3/8"	(34.93)	1-3/8"	(34.93)	1-3/4"	(44.45)	1-3/4"	(44.45)	1-3/4"	(44.45)
1.125	(28.58)	1.125	(28.58)	1.625	(41.28)	1.625	(41.28)	1.625	(41.28)
1.625	(41.28)	1.625	(41.28)	2.000	(50.80)	2.000	(50.80)	2.000	(50.80)
1.499	(38.08)	1.499	(38.08)	1.999	(50.78)	1.999	(50.78)	1.999	(50.78)
1.999	(50.78)	1.999	(50.78)	2.374	(60.30)	2.374	(60.30)	2.374	(60.30)
.500	(12.70)	.500	(12.70)	.625	(15.88)	.625	(15.88)	.625	(15.88)
.625	(15.88)	.625	(15.88)	.750	(19.05)	.750	(19.05)	.750	(19.05)
1.250	(31.75)	1.250	(31.75)	1.500	(38.10)	1.500	(38.10)	1.500	(38.10)
7/8 - 14		7/8 - 14		1-1/4 - 12		1-1/4 - 12		1-1/4 - 12	
1-1/4 - 12		1-1/4 - 12		1-1/2 - 12		1-1/2 - 12		1-1/2 - 12	
.750	(19.05)	.750	(19.05)	1.000	(25.40)	1.000	(25.40)	1.000	(25.40)
.625	(15.88)	.625	(15.88)	.750	(19.05)	.750	(19.05)	.750	(19.05)
.813	(12.70)	.813	(12.70)	1.125	(15.88)	1.125	(15.88)	1.125	(15.88)
1.125	(28.58)	1.125	(28.58)	1.500	(38.10)	1.500	(38.10)	1.500	(38.10)
4.500	(114.30)	5.500	(139.70)	6.500	(165.10)	7.500	(190.50)	8.500	(215.90)
.500	(12.70)	.500	(12.70)	.750	(19.05)	.750	(19.05)	.750	(19.05)
1 - 14		1 - 14		1-3/8 - 12		1-3/8 - 12		1-3/8 - 12	
1-3/8 - 12		1-3/8 - 12		1-3/4 - 12		1-3/4 - 12		1-3/4 - 12	
1.750	(44.45)	1.750	(44.45)	2.000	(50.80)	2.000	(50.80)	2.000	(50.80)
1.250	(31.75)	1.250	(31.75)	1.500	(38.10)	1.500	(38.10)	1.500	(38.10)
3/4 - 16		3/4 - 16		1 - 14		1 - 14		1 - 14	
1 - 14		1 - 14		1-1/4 - 12		1-1/4 - 12		1-1/4 - 12	
1.250	(31.75)	1.250	(31.75)	1.500	(38.10)	1.500	(38.10)	1.500	(38.10)
4.250	(107.95)	4.500	(114.30)	5.000	(127.00)	5.125	(130.18)	5.125	(130.18)
1.250	(31.75)	1.250	(31.75)	1.500	(38.10)	1.500	(38.10)	1.500	(38.10)
.750	(19.05)	.750	(19.05)	1.000	(25.40)	1.000	(25.40)	1.000	(25.40)
1.000	(25.40)	1.000	(25.40)	1.375	(34.93)	1.375	(34.93)	1.375	(34.93)
1.375	(34.93)	1.375	(34.93)	1.750	(44.45)	1.750	(44.45)	1.750	(44.45)
.938	(23.81)	.938	(23.81)	1.188	(30.16)	1.188	(30.16)	1.188	(30.16)
2.625	(66.68)	2.875	(73.03)	3.125	(79.38)	3.250	(82.55)	3.250	(82.55)
.875	(22.23)	.875	(22.23)	1.000	(25.40)	1.000	(25.40)	1.000	(25.40)
1.000	(25.40)	1.000	(25.40)	1.125	(28.58)	1.125	(28.58)	1.125	(28.58)
1.375	(34.93)	1.375	(34.93)	1.625	(41.28)	1.625	(41.28)	1.625	(41.28)
1.625	(41.28)	1.625	(41.28)	1.875	(47.63)	1.875	(47.63)	1.875	(47.63)
6.875	(174.63)	7.125	(180.98)	8.125	(206.38)	8.250	(209.55)	8.250	(209.55)
7.125	(180.98)	7.375	(187.33)	8.375	(212.73)	8.500	(215.90)	8.500	(215.90)
2.438	(61.91)	2.438	(61.91)	2.813	(71.44)	2.813	(71.44)	2.813	(71.44)
2.688	(68.26)	2.688	(68.26)	3.063	(77.79)	3.063	(77.79)	3.063	(77.79)

All dimensions in inches (mm)

NOTE

For strokes in excess of 30 inches, see "Stop Tube Selection" on page 45.

The centerline of the machine member that attaches to the swivel pin must be perpendicular to the centerline of the piston rod and the curved path must be in one place only. Any misalignment will cause excess side loading on the bearing and piston. This could lead to premature failure.

Series Q6/NQ Mounting Styles and Installation Dimensions

These mounts are ideal for straight line force transfer applications in which the cylinder is used in compression (pushing), as in push presses. For tension applications (pulling), a head rectangular mount is more appropriate.

The frame on which the cylinder is mounted must be sufficiently rigid to resist bending moments.

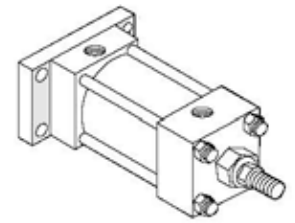

Code RS Cap Rectangular Flange Mounts (ANSI MF2)

DIMENSION		1 1/2" BORE (38.10)		2" BORE (50.80)		2 1/2" BORE (63.50)		3 1/4" BORE (82.55)		
Rod	Std.	5/8"	(15.88)	5/8"	(15.88)	5/8"	(15.88)	1"	(25.40)	
	O.S.	1"	(25.40)	1"	(25.40)	1"	(25.40)	1-3/8"	(34.93)	
A	Std.	.750	(19.05)	.750	(19.05)	.750	(19.05)	1.125	(28.58)	
	O.S.	1.125	(28.58)	1.125	(28.58)	1.125	(28.58)	1.625	(41.28)	
B +.000										
	-.002	Std.	1.124	(28.55)	1.124	(28.55)	1.124	(28.55)	1.499	(38.08)
		O.S.	1.499	(38.08)	1.499	(38.08)	1.499	(38.08)	1.999	(50.78)
C	Std.	.375	(9.53)	.375	(9.53)	.375	(9.53)	.500	(12.70)	
	O.S.	.500	(12.70)	.500	(12.70)	.500	(12.70)	.625	(15.88)	
CB		.750	(19.05)	.750	(19.05)	.750	(19.05)	1.250	(31.75)	
CC	Std.	1/2 - 20		1/2 - 20		1/2 - 20		7/8 - 14		
	O.S.	7/8 - 14		7/8 - 14		7/8 - 14		1-1/4 - 12		
D	Std.	.500	(12.70)	.500	(12.70)	.500	(12.70)	.813	(20.64)	
	O.S.	.813	(20.64)	.813	(20.64)	.813	(20.64)	1.125	(28.58)	
E		2.000	(50.80)	2.500	(63.50)	3.000	(76.20)	3.750	(95.25)	
EE		.375	(9.53)	.375	(9.53)	.375	(9.53)	.500	(12.70)	
F		.375	(9.53)	.375	(9.53)	.375	(9.53)	.625	(15.88)	
FB		.313	(7.94)	.375	(9.53)	.375	(9.53)	.438	(11.11)	
FF	Std.	5/8 - 18		5/8 - 18		5/8 - 18		1 - 14		
	O.S.	1 - 14		1 - 14		1 - 14		1-3/8 - 12		
G		1.500	(38.10)	1.500	(38.10)	1.500	(38.10)	1.750	(44.45)	
J		1.000	(25.40)	1.000	(25.40)	1.000	(25.40)	1.250	(31.75)	
K		.250	(6.35)	.313	(7.94)	.313	(7.94)	.375	(9.53)	
KK	Std.	7/16 - 20		7/16 - 20		7/16 - 20		3/4 - 16		
	O.S.	3/4 - 16		3/4 - 16		3/4 - 16		1 - 14		
LB		3.625	(92.08)	3.625	(92.08)	3.750	(95.25)	4.250	(107.95)	
MM	Std.	.625	(15.88)	.625	(15.88)	.625	(15.88)	1.000	(25.40)	
	O.S.	1.000	(25.40)	1.000	(25.40)	1.000	(25.40)	1.375	(34.93)	
P		2.313	(58.74)	2.313	(58.74)	2.438	(61.91)	2.625	(66.68)	
R		1.428	(36.27)	1.838	(46.68)	2.192	(55.67)	2.758	(70.05)	
TF		2.750	(69.85)	3.375	(85.73)	3.875	(98.43)	4.687	(119.05)	
UF		3.375	(85.73)	4.125	(104.78)	4.625	(117.48)	5.500	(139.70)	
VF	Std.	.625	(15.88)	.625	(15.88)	.625	(15.88)	.875	(22.23)	
	O.S.	.875	(22.23)	.875	(22.23)	.875	(22.23)	1.000	(25.40)	
WF	Std.	1.000	(25.40)	1.000	(25.40)	1.000	(25.40)	1.375	(34.93)	
	O.S.	1.375	(34.93)	1.375	(34.93)	1.375	(34.93)	1.625	(41.28)	
Y	Std.	1.875	(47.63)	1.875	(47.63)	1.875	(47.63)	2.438	(61.91)	
	O.S.	2.250	(57.15)	2.250	(57.15)	2.250	(57.15)	2.688	(68.26)	
ZF	Std.	5.000	(127.00)	5.000	(127.00)	5.125	(130.18)	6.250	(158.75)	
	O.S.	5.375	(136.53)	5.375	(136.53)	5.500	(139.70)	6.500	(165.10)	

All dimensions in inches (mm)

Series Q6/NQ Mounting Styles and Installation Dimensions

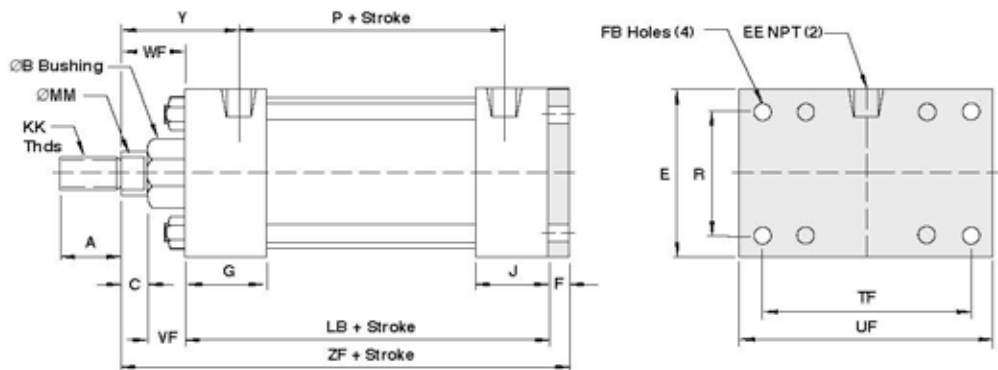

Code RS Cap Rectangular Flange Mounts (ANSI MF2)

4" BORE (101.60)		5" BORE (127.00)		6" BORE (152.40)	
1"	(25.40)	1"	(25.40)	1-3/8"	(34.93)
1-3/8"	(34.93)	1-3/8"	(34.93)	1-3/4"	(44.45)
1.125	(28.58)	1.125	(28.58)	1.625	(41.28)
1.625	(41.28)	1.625	(41.28)	2.000	(50.80)
1.499	(38.08)	1.499	(38.08)	1.999	(50.78)
1.999	(50.78)	1.999	(50.78)	2.374	(60.30)
.500	(12.70)	.500	(12.70)	.625	(15.88)
.625	(15.88)	.625	(15.88)	.750	(19.05)
1.250	(31.75)	1.250	(31.75)	1.500	(38.10)
7/8 - 14		7/8 - 14		1-1/4 - 12	
1-1/4 - 12		1-1/4 - 12		1-1/2 - 12	
.813	(12.70)	.813	(12.70)	1.125	(15.88)
1.125	(28.58)	1.125	(28.58)	1.500	(38.10)
4.500	(114.30)	5.500	(139.70)	6.500	(165.10)
.500	(12.70)	.500	(12.70)	.750	(19.05)
.625	(15.88)	.625	(15.88)	.750	(19.05)
.438	(11.11)	.563	(14.29)	.563	(14.29)
1 - 14		1 - 14		1-3/8 - 12	
1-3/8 - 12		1-3/8 - 12		1-3/4 - 12	
1.750	(44.45)	1.750	(44.45)	2.000	(50.80)
1.250	(31.75)	1.250	(31.75)	1.500	(38.10)
.375	(9.53)	.438	(11.11)	.438	(11.11)
3/4 - 16		3/4 - 16		1 - 14	
1 - 14		1 - 14		1-1/4 - 12	
4.250	(107.95)	4.500	(114.30)	5.000	(127.00)
1.000	(25.40)	1.000	(25.40)	1.375	(34.93)
1.375	(34.93)	1.375	(34.93)	1.750	(44.45)
2.625	(66.68)	2.875	(73.03)	3.125	(79.38)
3.323	(84.40)	4.101	(104.16)	4.879	(123.93)
5.438	(138.11)	6.625	(168.28)	7.625	(193.68)
6.250	(158.75)	7.625	(193.68)	8.625	(219.08)
.875	(22.23)	.875	(22.23)	1.000	(25.40)
1.000	(25.40)	1.000	(25.40)	1.125	(28.58)
1.375	(34.93)	1.375	(34.93)	1.625	(41.28)
1.625	(41.28)	1.625	(41.28)	1.875	(47.63)
2.438	(61.91)	2.438	(61.91)	2.813	(71.44)
2.688	(68.26)	2.688	(68.26)	3.063	(77.79)
6.250	(158.75)	6.500	(165.10)	7.375	(187.33)
6.500	(165.10)	6.750	(171.45)	7.625	(193.68)

All dimensions in inches (mm)

NOTE

For strokes in excess of 30 inches, see "Stop Tube Selection" on page 45.
Cap rectangular mounts are recommended for heavy duty applications.

Series Q6/NQ Mounting Styles and Installation Dimensions

These mounts are ideal for straight line force transfer applications in which the cylinder is used in compression (pushing). The mounting surface should be flat and the rod end cartridge should be piloted into it.

The frame on which the cylinder is mounted must be sufficiently rigid to resist bending moments.

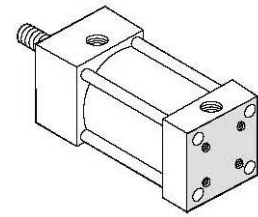

Code PP Cap Square Mounts

(ANSI ME4)

DIMENSION		7" BORE (177.80)		8" BORE (203.20)	
Rod	Std.	1-3/8"	(34.93)	1-3/8"	(34.93)
	O.S.	1-3/4"	(44.45)	1-3/4"	(44.45)
A	Std.	1.625	(41.28)	1.625	(41.28)
	O.S.	2.000	(50.80)	2.000	(50.80)
B +.000 -.002	Std.	1.625	(41.28)	1.625	(41.28)
	O.S.	2.000	(50.80)	2.000	(50.80)
C	Std.	.625	(15.88)	.625	(15.88)
	O.S.	.750	(19.05)	.750	(19.05)
CC	Std.	1-1/4 - 12		1-1/4 - 12	
	O.S.	1-1/2 - 12		1-1/2 - 12	
D	Std.	1.125	(15.88)	1.125	(15.88)
	O.S.	1.500	(38.10)	1.500	(38.10)
E		7.500	(190.50)	8.500	(215.90)
EB		.688	(17.46)	.688	(17.46)
EE		.750	(19.05)	.750	(19.05)
FF	Std.	1-3/8 - 12		1-3/8 - 12	
	O.S.	1-3/4 - 12		1-3/4 - 12	
G		2.000	(50.80)	2.000	(50.80)
J		1.500	(38.10)	1.500	(38.10)
K		.563	(14.29)	.563	(14.29)
KK	Std.	1 - 14		1 - 14	
	O.S.	1-1/4 - 12		1-1/4 - 12	
LB		5.125	(130.18)	5.125	(130.18)
MM	Std.	1.375	(34.93)	1.375	(34.93)
	O.S.	1.750	(44.45)	1.750	(44.45)
P		3.250	(82.55)	3.250	(82.55)
R		5.639	(145.54)	6.442	(163.63)
TE		6.750	(171.45)	7.570	(192.27)
VF	Std.	1.000	(25.40)	1.000	(25.40)
	O.S.	1.125	(28.58)	1.125	(28.58)
Y	Std.	2.813	(71.44)	2.813	(71.44)
	O.S.	3.063	(77.79)	3.063	(77.79)
ZB	Std.	7.313	(185.74)	7.313	(185.74)
	O.S.	7.563	(192.09)	7.563	(192.09)

All dimensions in inches (mm)

NOTE

For strokes in excess of 30 inches, see "Stop Tube Selection" on page 45.

The force of the load should be perpendicular to the mounting surface and parallel to the centerline of the piston rod. For eccentric loads, the larger of the two available rods in each bore size is recommended. Stop tubes should also be considered.

Series Q6/NQ Mounting Styles and Installation Dimensions

Code PP Cap Square Mounts (ANSI ME4)

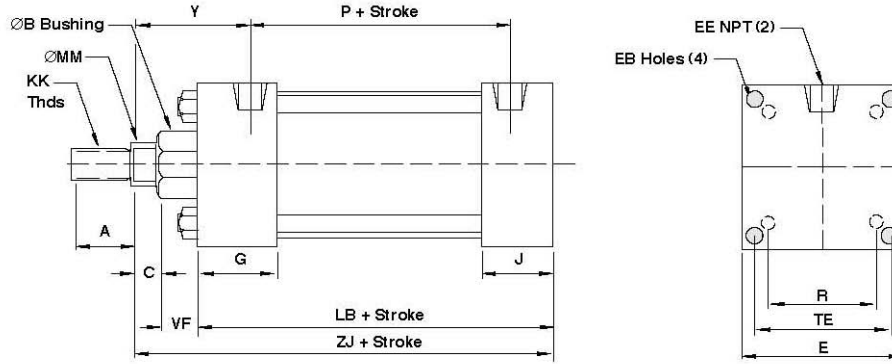

Series Q6/NQ Mounting Styles and Installation Dimensions

These mounts are for applications in which the machine member travels in a curved path in one plane.

The mount can be used both in compression (push) and tension (pull) applications. When used in compression

applications, head trunnion mounts provide a longer maximum stroke than cap trunnion mounts.

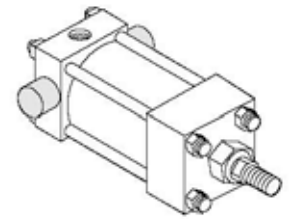

Code WS Cap Trunnion Mounts (ANSI MT2)

DIMENSION		1 1/2" BORE (38.10)		2" BORE (50.80)		2 1/2" BORE (63.50)		3 1/4" BORE (82.55)	
Rod	Std.	5/8"	(15.88)	5/8"	(15.88)	5/8"	(15.88)	1"	(25.40)
	O.S.	1"	(25.40)	1"	(25.40)	1"	(25.40)	1-3/8"	(34.93)
A	Std.	.750	(19.05)	.750	(19.05)	.750	(19.05)	1.125	(28.58)
	O.S.	1.125	(28.58)	1.125	(28.58)	1.125	(28.58)	1.625	(41.28)
B +.000 -.002	Std.	1.124	(28.55)	1.124	(28.55)	1.124	(28.55)	1.499	(38.08)
	O.S.	1.499	(38.08)	1.499	(38.08)	1.499	(38.08)	1.999	(50.78)
C	Std.	.375	(9.53)	.375	(9.53)	.375	(9.53)	.500	(12.70)
	O.S.	.500	(12.70)	.500	(12.70)	.500	(12.70)	.625	(15.88)
CC	Std.	1/2 - 20		1/2 - 20		1/2 - 20		7/8 - 14	
	O.S.	7/8 - 14		7/8 - 14		7/8 - 14		1-1/4 - 12	
D	Std.	.500	(12.70)	.500	(12.70)	.500	(12.70)	.875	(22.23)
	O.S.	.875	(22.23)	.875	(22.23)	.875	(22.23)	1.125	(28.58)
E		2.000	(50.80)	2.500	(63.50)	3.000	(76.20)	3.750	(95.25)
EE		.375	(9.53)	.375	(9.53)	.375	(9.53)	.500	(12.70)
FF	Std.	5/8 - 18		5/8 - 18		5/8 - 18		1 - 14	
	O.S.	1 - 14		1 - 14		1 - 14		1-3/8 - 12	
G		1.500	(38.10)	1.500	(38.10)	1.500	(38.10)	1.750	(44.45)
J		1.000	(25.40)	1.000	(25.40)	1.000	(25.40)	1.250	(31.75)
K		.250	(6.35)	.313	(7.94)	.313	(7.94)	.375	(9.53)
KK	Std.	7/16 - 20		7/16 - 20		7/16 - 20		3/4 - 16	
	O.S.	3/4 - 16		3/4 - 16		3/4 - 16		1 - 14	
LB		3.625	(92.08)	3.625	(92.08)	3.750	(95.25)	4.250	(107.95)
MM	Std.	.625	(15.88)	.625	(15.88)	.625	(15.88)	1.000	(25.40)
	O.S.	1.000	(25.40)	1.000	(25.40)	1.000	(25.40)	1.375	(34.93)
P		2.313	(58.74)	2.313	(58.74)	2.438	(61.91)	2.625	(66.68)
R		1.428	(36.27)	1.838	(46.68)	2.192	(55.67)	2.758	(70.05)
TD +.000 -.001		1.000	(25.40)	1.000	(25.40)	1.000	(25.40)	1.000	(25.40)
TL		1.000	(25.40)	1.000	(25.40)	1.000	(25.40)	1.000	(25.40)
UT		4.000	(101.60)	4.500	(114.30)	5.000	(127.00)	5.750	(146.05)
VF	Std.	.625	(15.88)	.625	(15.88)	.625	(15.88)	.875	(22.23)
	O.S.	.875	(22.23)	.875	(22.23)	.875	(22.23)	1.000	(25.40)
WF	Std.	1.000	(25.40)	1.000	(25.40)	1.000	(25.40)	1.375	(34.93)
	O.S.	1.375	(34.93)	1.375	(34.93)	1.375	(34.93)	1.625	(41.28)
XJ	Std.	4.125	(104.78)	4.125	(104.78)	4.250	(107.95)	5.000	(127.00)
	O.S.	5.750	(146.05)	5.750	(146.05)	5.875	(149.23)	7.125	(180.98)
Y	Std.	1.875	(47.63)	1.875	(47.63)	1.875	(47.63)	2.438	(61.91)
	O.S.	2.250	(57.15)	2.250	(57.15)	2.250	(57.15)	2.688	(68.26)
ZB	Std.	4.875	(123.83)	4.938	(125.41)	5.063	(128.59)	6.000	(152.40)
	O.S.	5.250	(133.35)	5.313	(134.94)	5.438	(138.11)	6.250	(158.75)

All dimensions in inches (mm)

Series Q6/NQ Mounting Styles and Installation Dimensions

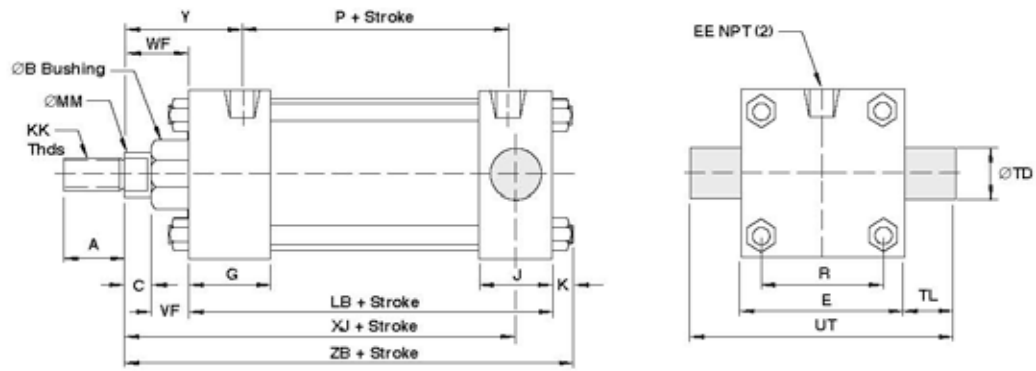

Code WS Cap Trunnion Mounts (ANSI MT2)

4" BORE (101.60)		5" BORE (127.00)		6" BORE (152.40)		7" BORE (177.80)		8" BORE (203.20)	
1"	(25.40)	1"	(25.40)	1-3/8"	(34.93)	1-3/8"	(34.93)	1-3/8"	(34.93)
1-3/8"	(34.93)	1-3/8"	(34.93)	1-3/4"	(44.45)	1-3/4"	(44.45)	1-3/4"	(44.45)
1.125	(28.58)	1.125	(28.58)	1.625	(41.28)	1.625	(41.28)	1.625	(41.28)
1.625	(41.28)	1.625	(41.28)	2.000	(50.80)	2.000	(50.80)	2.000	(50.80)
1.499	(38.08)	1.499	(38.08)	1.999	(50.78)	1.999	(50.78)	1.999	(50.78)
1.999	(50.78)	1.999	(50.78)	2.374	(60.30)	2.374	(60.30)	2.374	(60.30)
.500	(12.70)	.500	(12.70)	.625	(15.88)	.625	(15.88)	.625	(15.88)
.625	(15.88)	.625	(15.88)	.750	(19.05)	.750	(19.05)	.750	(19.05)
7/8 - 14		7/8 - 14		1-1/4 - 12		1-1/4 - 12		1-1/4 - 12	
1-1/4 - 12		1-1/4 - 12		1-1/2 - 12		1-1/2 - 12		1-1/2 - 12	
.875	(22.23)	.875	(22.23)	1.125	(15.88)	1.125	(15.88)	1.125	(15.88)
1.125	(28.58)	1.125	(28.58)	1.500	(38.10)	1.500	(38.10)	1.500	(38.10)
4.500	(114.30)	5.500	(139.70)	6.500	(165.10)	7.500	(190.50)	8.500	(215.90)
.500	(12.70)	.500	(12.70)	.750	(19.05)	.750	(19.05)	.750	(19.05)
1 - 14		1 - 14		1-3/8 - 12		1-3/8 - 12		1-3/8 - 12	
1-3/8 - 12		1-3/8 - 12		1-3/4 - 12		1-3/4 - 12		1-3/4 - 12	
1.750	(44.45)	1.750	(44.45)	2.000	(50.80)	2.000	(50.80)	2.000	(50.80)
1.250	(31.75)	1.250	(31.75)	1.500	(38.10)	1.500	(38.10)	1.500	(38.10)
.375	(9.53)	.438	(11.11)	.438	(11.11)	.563	(14.29)	.563	(14.29)
3/4 - 16		3/4 - 16		1 - 14		1 - 14		1 - 14	
1 - 14		1 - 14		1-1/4 - 12		1-1/4 - 12		1-1/4 - 12	
4.250	(107.95)	4.500	(114.30)	5.000	(127.00)	5.125	(130.18)	5.125	(130.18)
1.000	(25.40)	1.000	(25.40)	1.375	(34.93)	1.375	(34.93)	1.375	(34.93)
1.375	(34.93)	1.375	(34.93)	1.750	(44.45)	1.750	(44.45)	1.750	(44.45)
2.625	(66.68)	2.875	(73.03)	3.125	(79.38)	3.250	(82.55)	3.250	(82.55)
3.323	(84.40)	4.101	(104.16)	4.879	(123.92)	5.730	(145.54)	6.435	(163.44)
1.000	(25.40)	1.000	(25.40)	1.375	(34.93)	1.375	(34.93)	1.375	(34.93)
1.000	(25.40)	1.000	(25.40)	1.375	(34.93)	1.375	(34.93)	1.375	(34.93)
5.500	(165.10)	7.500	(190.50)	9.250	(234.95)	10.250	(260.35)	11.250	(285.75)
.875	(22.23)	.875	(22.23)	1.000	(25.40)	1.000	(25.40)	1.000	(25.40)
1.000	(25.40)	1.000	(25.40)	1.125	(28.58)	1.125	(28.58)	1.125	(28.58)
1.375	(34.93)	1.375	(34.93)	1.625	(41.28)	1.625	(41.28)	1.625	(41.28)
1.625	(41.28)	1.625	(41.28)	1.875	(47.63)	1.875	(47.63)	1.875	(47.63)
5.250	(133.35)	5.500	(139.70)	6.125	(155.58)	6.250	(158.75)	6.250	(158.75)
7.125	(180.98)	7.375	(187.33)	8.375	(212.73)	8.500	(215.90)	8.500	(215.90)
2.438	(61.91)	2.438	(61.91)	2.813	(71.44)	2.813	(71.44)	2.813	(71.44)
2.688	(68.26)	2.688	(68.26)	3.063	(77.79)	3.063	(77.79)	3.063	(77.79)
5.000	(152.40)	6.313	(160.34)	7.063	(179.39)	7.313	(185.74)	7.313	(185.74)
5.250	(158.75)	6.563	(166.69)	7.313	(185.74)	7.563	(192.09)	7.563	(192.09)

All dimensions in inches (mm)

NOTE

For strokes in excess of 30 inches, see "Stop tube selection" on page 45.

The frame on which the cylinder is mounted must be sufficiently rigid to resist bending moments.

Series Q6/NQ Mounting Styles and Installation Dimensions

These mounts are for applications in which the machine member travels in a curved path in one plane.

The mount can be used both in compression (push) and tension (pull) applications. When used in compression

applications, head trunnion mounts provide a longer maximum stroke than cap trunnion mounts.

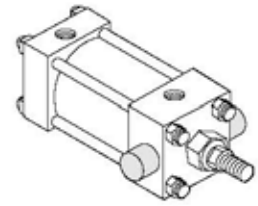

Code US Head Trunnion Mounts (ANSI MT1)

DIMENSION		1 1/2" BORE (38.10)		2" BORE (50.80)		2 1/2" BORE (63.50)		3 1/4" BORE (82.55)	
Rod	Std.	5/8"	(15.88)	5/8"	(15.88)	5/8"	(15.88)	1"	(25.40)
	O.S.	1"	(25.40)	1"	(25.40)	1"	(25.40)	1-3/8"	(34.93)
A	Std.	.750	(19.05)	.750	(19.05)	.750	(19.05)	1.125	(28.58)
	O.S.	1.125	(28.58)	1.125	(28.58)	1.125	(28.58)	1.625	(41.28)
+.000									
-.002B	Std.	1.124	(28.55)	1.124	(28.55)	1.124	(28.55)	1.499	(38.08)
	O.S.	1.499	(38.08)	1.499	(38.08)	1.499	(38.08)	1.999	(50.78)
C	Std.	.375	(9.53)	.375	(9.53)	.375	(9.53)	.500	(12.70)
	O.S.	.500	(12.70)	.500	(12.70)	.500	(12.70)	.625	(15.88)
CC	Std.	1/2 - 20		1/2 - 20		1/2 - 20		7/8 - 14	
	O.S.	7/8 - 14		7/8 - 14		7/8 - 14		1-1/4 - 12	
D	Std.	.500	(12.70)	.500	(12.70)	.500	(12.70)	.875	(22.23)
	O.S.	.875	(22.23)	.875	(22.23)	.875	(22.23)	1.125	(28.58)
E		2.000	(50.80)	2.500	(63.50)	3.000	(76.20)	3.750	(95.25)
EE		.375	(9.53)	.375	(9.53)	.375	(9.53)	.500	(12.70)
FF	Std.	5/8 - 18		5/8 - 18		5/8 - 18		1 - 14	
	O.S.	1 - 14		1 - 14		1 - 14		1-3/8 - 12	
G		1.500	(38.10)	1.500	(38.10)	1.500	(38.10)	1.750	(44.45)
J		1.000	(25.40)	1.000	(25.40)	1.000	(25.40)	1.250	(31.75)
K		.250	(6.35)	.313	(7.94)	.313	(7.94)	.375	(9.53)
KK	Std.	7/16 - 20		7/16 - 20		7/16 - 20		3/4 - 16	
	O.S.	3/4 - 16		3/4 - 16		3/4 - 16		1 - 14	
LB		3.625	(92.08)	3.625	(92.08)	3.750	(95.25)	4.250	(107.95)
MM	Std.	.625	(15.88)	.625	(15.88)	.625	(15.88)	1.000	(25.40)
	O.S.	1.000	(25.40)	1.000	(25.40)	1.000	(25.40)	1.375	(34.93)
P		2.313	(58.74)	2.313	(58.74)	2.438	(61.91)	2.625	(66.68)
R		1.428	(36.27)	1.838	(46.68)	2.192	(55.67)	2.758	(70.05)
TD +.000 -.001		1.000	(25.40)	1.000	(25.40)	1.000	(25.40)	1.000	(25.40)
TL		1.000	(25.40)	1.000	(25.40)	1.000	(25.40)	1.000	(25.40)
UT		4.000	(101.60)	4.500	(114.30)	5.000	(127.00)	5.750	(146.05)
VF	Std.	.625	(15.88)	.625	(15.88)	.625	(15.88)	.875	(22.23)
	O.S.	.875	(22.23)	.875	(22.23)	.875	(22.23)	1.000	(25.40)
WF	Std.	1.000	(25.40)	1.000	(25.40)	1.000	(25.40)	1.375	(34.93)
	O.S.	1.375	(34.93)	1.375	(34.93)	1.375	(34.93)	1.625	(41.28)
XJ	Std.	4.125	(104.78)	4.125	(104.78)	4.250	(107.95)	5.000	(127.00)
	O.S.	5.750	(146.05)	5.750	(146.05)	5.875	(149.23)	7.125	(180.98)
Y	Std.	1.875	(47.63)	1.875	(47.63)	1.875	(47.63)	2.438	(61.91)
	O.S.	2.250	(57.15)	2.250	(57.15)	2.250	(57.15)	2.688	(68.26)
ZB	Std.	4.875	(123.83)	4.938	(125.41)	5.063	(128.59)	6.000	(152.40)
	O.S.	5.250	(133.35)	5.313	(134.94)	5.438	(138.11)	6.250	(158.75)

All dimensions in inches (mm)

Series Q6/NQ Mounting Styles and Installation Dimensions

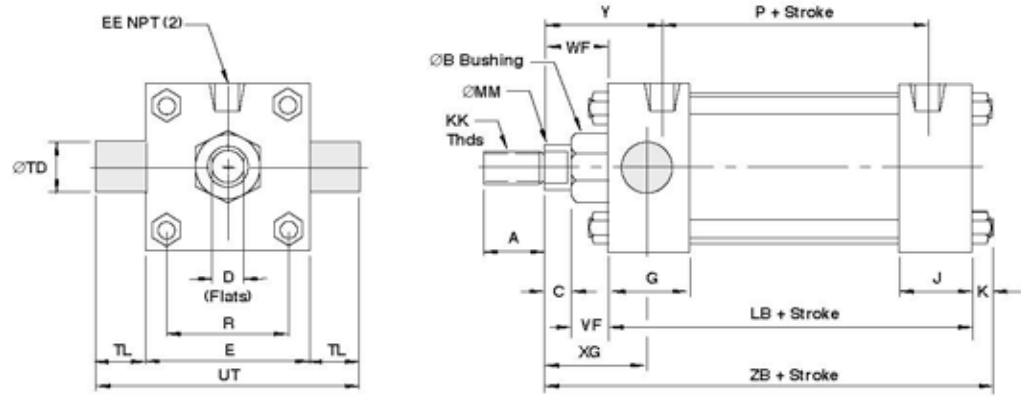

Code US Head Trunnion Mounts (ANSI MT1)

4" BORE (101.60)		5" BORE (127.00)		6" BORE (152.40)		7" BORE (177.80)		8" BORE (203.20)	
1"	(25.40)	1"	(25.40)	1-3/8"	(34.93)	1-3/8"	(34.93)	1-3/8"	(34.93)
1-3/8"	(34.93)	1-3/8"	(34.93)	1-3/4"	(44.45)	1-3/4"	(44.45)	1-3/4"	(44.45)
1.125	(28.58)	1.125	(28.58)	1.625	(41.28)	1.625	(41.28)	1.625	(41.28)
1.625	(41.28)	1.625	(41.28)	2.000	(50.80)	2.000	(50.80)	2.000	(50.80)
1.499	(38.08)	1.499	(38.08)	1.999	(50.78)	1.999	(50.78)	1.999	(50.78)
1.999	(50.78)	1.999	(50.78)	2.374	(60.30)	2.374	(60.30)	2.374	(60.30)
.500	(12.70)	.500	(12.70)	.625	(15.88)	.625	(15.88)	.625	(15.88)
.625	(15.88)	.625	(15.88)	.750	(19.05)	.750	(19.05)	.750	(19.05)
7/8 - 14		7/8 - 14		1-1/4 - 12		1-1/4 - 12		1-1/4 - 12	
1-1/4 - 12		1-1/4 - 12		1-1/2 - 12		1-1/2 - 12		1-1/2 - 12	
.875	(22.23)	.875	(22.23)	1.125	(15.88)	1.125	(15.88)	1.125	(15.88)
1.125	(28.58)	1.125	(28.58)	1.500	(38.10)	1.500	(38.10)	1.500	(38.10)
4.500	(114.30)	5.500	(139.70)	6.500	(165.10)	7.500	(190.50)	8.500	(215.90)
.500	(12.70)	.500	(12.70)	.750	(19.05)	.750	(19.05)	.750	(19.05)
1 - 14		1 - 14		1-3/8 - 12		1-3/8 - 12		1-3/8 - 12	
1-3/8 - 12		1-3/8 - 12		1-3/4 - 12		1-3/4 - 12		1-3/4 - 12	
1.750	(44.45)	1.750	(44.45)	2.000	(50.80)	2.000	(50.80)	2.000	(50.80)
1.250	(31.75)	1.250	(31.75)	1.500	(38.10)	1.500	(38.10)	1.500	(38.10)
.375	(9.53)	.438	(11.11)	.438	(11.11)	.563	(14.29)	.563	(14.29)
3/4 - 16		3/4 - 16		1 - 14		1 - 14		1 - 14	
1 - 14		1 - 14		1-1/4 - 12		1-1/4 - 12		1-1/4 - 12	
4.250	(107.95)	4.500	(114.30)	5.000	(127.00)	5.125	(130.18)	5.125	(130.18)
1.000	(25.40)	1.000	(25.40)	1.375	(34.93)	1.375	(34.93)	1.375	(34.93)
1.375	(34.93)	1.375	(34.93)	1.750	(44.45)	1.750	(44.45)	1.750	(44.45)
2.625	(66.68)	2.875	(73.03)	3.125	(79.38)	3.250	(82.55)	3.250	(82.55)
3.323	(84.40)	4.101	(104.16)	4.879	(123.92)	5.730	(145.54)	6.435	(163.44)
1.000	(25.40)	1.000	(25.40)	1.375	(34.93)	1.375	(34.93)	1.375	(34.93)
1.000	(25.40)	1.000	(25.40)	1.375	(34.93)	1.375	(34.93)	1.375	(34.93)
6.500	(165.10)	7.500	(190.50)	9.250	(234.95)	10.250	(260.35)	11.250	(285.75)
.875	(22.23)	.875	(22.23)	1.000	(25.40)	1.000	(25.40)	1.000	(25.40)
1.000	(25.40)	1.000	(25.40)	1.125	(28.58)	1.125	(28.58)	1.125	(28.58)
1.375	(34.93)	1.375	(34.93)	1.625	(41.28)	1.625	(41.28)	1.625	(41.28)
1.625	(41.28)	1.625	(41.28)	1.875	(47.63)	1.875	(47.63)	1.875	(47.63)
5.250	(133.35)	5.500	(139.70)	6.125	(155.58)	6.250	(158.75)	6.250	(158.75)
7.125	(180.98)	7.375	(187.33)	8.375	(212.73)	8.500	(215.90)	8.500	(215.90)
2.438	(61.91)	2.438	(61.91)	2.813	(71.44)	2.813	(71.44)	2.813	(71.44)
2.688	(68.26)	2.688	(68.26)	3.063	(77.79)	3.063	(77.79)	3.063	(77.79)
6.000	(152.40)	6.313	(160.34)	7.063	(179.39)	7.313	(185.74)	7.313	(185.74)
6.250	(158.75)	6.563	(166.69)	7.313	(185.74)	7.563	(192.09)	7.563	(192.09)

All dimensions in inches (mm)

NOTE

For strokes in excess of 30 inches, see "Stop Tube Selection" on page 45.

It is recommended that rigidly mounted pillow blocks with bearings at least as long as the trunnion pins be used. The pillow blocks should be installed as close to the shoulder of the trunnion as possible.

Series Q6/NQ Mounting Styles and Installation Dimensions

These mounts are for straight line force transfer applications in which the cylinder is used in tension (pulling).

The mounting surface should be flat and the rod end cartridge should be piloted into it.

The frame on which the cylinder is mounted must be sufficiently rigid to resist bending moments.

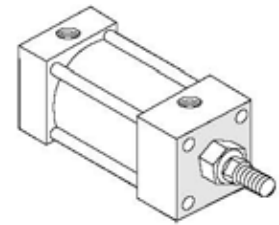

16 Sleeve Nut Construction
Basic Cylinder Side Tapped (Universal)

Code FM Sleeve Nut, for Tapped Face Mounts

DIMENSION		1 1/2" BORE (38.10)		2" BORE (50.80)		2 1/2" BORE (63.50)		3 1/4" BORE (82.55)		
Rod	Std.	5/8"	(15.88)	5/8"	(15.88)	5/8"	(15.88)	1"	(25.40)	
	O.S.	1"	(25.40)	1"	(25.40)	1"	(25.40)	1-3/8"	(34.93)	
A	Std.	.750	(19.05)	.750	(19.05)	.750	(19.05)	1.125	(28.58)	
	O.S.	1.125	(28.58)	1.125	(28.58)	1.125	(28.58)	1.625	(41.28)	
AA		2.020	(51.31)	2.600	(66.04)	3.100	(78.74)	3.900	(99.06)	
B	+ .000									
	-.002	Std.	1.124	(28.55)	1.124	(28.55)	1.124	(28.55)	1.499	(38.08)
		O.S.	1.499	(38.08)	1.499	(38.08)	1.499	(38.08)	1.999	(50.78)
C	Std.	.375	(9.53)	.375	(9.53)	.375	(9.53)	.500	(12.70)	
	O.S.	.500	(12.70)	.500	(12.70)	.500	(12.70)	.625	(15.88)	
CC	Std.	1/2 - 20		1/2 - 20		1/2 - 20		7/8 - 14		
	O.S.	7/8 - 14		7/8 - 14		7/8 - 14		1-1/4 - 12		
D	Std.	.500	(12.70)	.500	(12.70)	.500	(12.70)	.813	(20.64)	
	O.S.	.813	(20.64)	.813	(20.64)	.813	(20.64)	1.125	(28.58)	
DD		1/4 - 28		5/16 - 24		5/16 - 24		3/8 - 24		
E		2.000	(50.80)	2.500	(63.50)	3.000	(76.20)	3.750	(95.25)	
EE		.375	(9.53)	.375	(9.53)	.375	(9.53)	.500	(12.70)	
FF	Std.	5/8 - 18		5/8 - 18		5/8 - 18		1 - 14		
	O.S.	1 - 14		1 - 14		1 - 14		1-3/8 - 12		
G		1.500	(38.10)	1.500	(38.10)	1.500	(38.10)	1.750	(44.45)	
J		1.000	(25.40)	1.000	(25.40)	1.000	(25.40)	1.250	(31.75)	
KK	Std.	7/16 - 20		7/16 - 20		7/16 - 20		3/4 - 16		
	O.S.	3/4 - 16		3/4 - 16		3/4 - 16		1 - 14		
LB		3.625	(92.08)	3.625	(92.08)	3.750	(95.25)	4.250	(107.95)	
MM	Std.	.625	(15.88)	.625	(15.88)	.625	(15.88)	1.000	(25.40)	
	O.S.	1.000	(25.40)	1.000	(25.40)	1.000	(25.40)	1.375	(34.93)	
NT	1/4 - 20	5/16 - 18	3/8 - 16	1/2 - 13	1/2 - 13	5/8 - 11	3/4 - 10			
ND		.375	(9.53)	.375	(9.53)	.500	(12.70)	.750	(19.05)	
P		2.313	(58.74)	2.313	(58.74)	2.438	(61.91)	2.625	(66.68)	
R		1.428	(36.27)	1.838	(46.68)	2.192	(55.67)	2.758	(70.05)	
SN		2.250	(57.15)	2.250	(57.15)	2.375	(60.33)	2.625	(66.68)	
TN		.625	(15.88)	.875	(22.23)	1.250	(31.75)	1.500	(38.10)	
VF	Std.	.625	(15.88)	.625	(15.88)	.625	(15.88)	.875	(22.23)	
	O.S.	.875	(22.23)	.875	(22.23)	.875	(22.23)	1.000	(25.40)	
WF	Std.	1.000	(25.40)	1.000	(25.40)	1.000	(25.40)	1.375	(34.93)	
	O.S.	1.375	(34.93)	1.375	(34.93)	1.375	(34.93)	1.625	(41.28)	
XT	Std.	1.938	(49.21)	1.938	(49.21)	1.938	(49.21)	2.438	(61.91)	
	O.S.	2.313	(58.74)	2.313	(58.74)	2.313	(58.74)	2.688	(68.26)	
Y	Std.	1.875	(47.63)	1.875	(47.63)	1.875	(47.63)	2.438	(61.91)	
	O.S.	2.250	(57.15)	2.250	(57.15)	2.250	(57.15)	2.688	(68.26)	
ZJ	Std.	4.625	(117.48)	4.625	(117.48)	4.750	(120.65)	5.625	(142.88)	
	O.S.	5.000	(127.00)	5.000	(127.00)	5.125	(130.18)	5.875	(149.23)	

All dimensions in inches (mm)

Series Q6/NQ Mounting Styles and Installation Dimensions

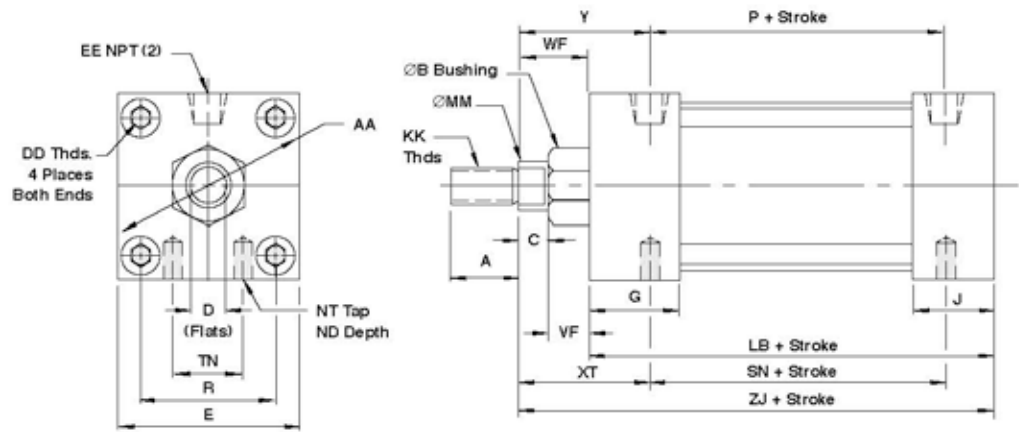

Code FM Sleeve Nut, for Tapped Face Mounts

4" BORE (101.60)		5" BORE (127.00)		6" BORE (152.40)	
1"	(25.40)	1"	(25.40)	1-3/8"	(34.93)
1-3/8"	(34.93)	1-3/8"	(34.93)	1-3/4"	(44.45)
1.125	(28.58)	1.125	(28.58)	1.625	(41.28)
1.625	(41.28)	1.625	(41.28)	2.000	(50.80)
4.700	(119.38)	5.800	(147.32)	6.900	(175.26)
1.499	(38.08)	1.499	(38.08)	1.999	(50.78)
1.999	(50.78)	1.999	(50.78)	2.374	(60.30)
.500	(12.70)	.500	(12.70)	.625	(15.88)
.625	(15.88)	.625	(15.88)	.750	(19.05)
7/8 - 14		7/8 - 14		1-1/4 - 12	
1-1/4 - 12		1-1/4 - 12		1-1/2 - 12	
.813	(20.64)	.813	(20.64)	1.125	(15.88)
1.125	(28.58)	1.125	(28.58)	1.500	(38.10)
3/8 - 24		1/2 - 20		1/2 - 20	
4.500	(114.30)	5.500	(139.70)	6.500	(165.10)
.500	(12.70)	.500	(12.70)	.750	(19.05)
1 - 14		1 - 14		1-3/8 - 12	
1-3/8 - 12		1-3/8 - 12		1-3/4 - 12	
1.750	(44.45)	1.750	(44.45)	2.000	(50.80)
1.250	(31.75)	1.250	(31.75)	1.500	(38.10)
3/4 - 16		3/4 - 16		1 - 14	
1 - 14		1 - 14		1-1/4 - 12	
4.250	(107.95)	4.500	(114.30)	5.000	(127.00)
1.000	(25.40)	1.000	(25.40)	1.375	(34.93)
1.375	(34.93)	1.375	(34.93)	1.750	(44.45)
.750	(19.05)	.938	(23.81)	1.125	(28.58)
2.625	(66.68)	2.875	(73.03)	3.125	(79.38)
3.323	(84.40)	4.101	(104.16)	4.879	(123.92)
2.625	(66.68)	2.875	(73.03)	3.125	(79.38)
2.063	(52.39)	2.688	(68.26)	3.250	(82.55)
.875	(22.23)	.875	(22.23)	1.000	(25.40)
1.000	(25.40)	1.000	(25.40)	1.125	(28.58)
1.375	(34.93)	1.375	(34.93)	1.625	(41.28)
1.625	(41.28)	1.625	(41.28)	1.875	(47.63)
2.438	(61.91)	2.438	(61.91)	2.813	(71.44)
2.688	(68.26)	2.688	(68.26)	3.063	(77.79)
2.438	(61.91)	2.438	(61.91)	2.813	(71.44)
2.688	(68.26)	2.688	(68.26)	3.063	(77.79)
5.625	(142.88)	5.625	(142.88)	6.625	(168.28)
5.875	(149.23)	5.875	(149.23)	6.875	(174.63)

All dimensions in inches (mm)

NOTE

For strokes in excess of 30 inches, see "Stop Tube Selection" on page 45.

The force of the load should be perpendicular to the mounting surface and parallel to the centerline of the piston rod. For eccentric loads, the larger of the two available rods in each bore size is recommended. Stop tubes should also be considered.

Series Q6/NQ Mounting Styles and Installation Dimensions

These mounts are for straight line force transfer applications. Both ends extended tie rod mounts are suited for tension and compression applications or applications where additional hardware is to be attached to cylinders.

The mounting surface should be flat and the frame on which the cylinder is mounted must be sufficiently rigid to resist bending moments.

Once fitted into the application framework, the nuts which are provided should be torqued to the values listed in the right column table.

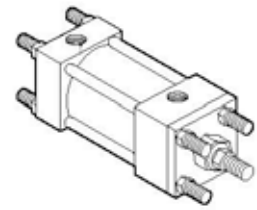

Codes NS Cap (MX2), MS Head (MX3), & LS Both Ends (MX1)
Extended Tie Rod Mounts

DIMENSION		1 1/2" BORE (38.10)		2" BORE (50.80)		2 1/2" BORE (63.50)		3 1/4" BORE (82.55)	
Rod	Std.	5/8"	(15.88)	5/8"	(15.88)	5/8"	(15.88)	1"	(25.40)
	O.S.	1"	(25.40)	1"	(25.40)	1"	(25.40)	1-3/8"	(34.93)
A	Std.	.750	(19.05)	.750	(19.05)	.750	(19.05)	1.125	(28.58)
	O.S.	1.125	(28.58)	1.125	(28.58)	1.125	(28.58)	1.625	(41.28)
B +.000 -.002	Std.	1.124	(28.55)	1.124	(28.55)	1.124	(28.55)	1.499	(38.08)
	O.S.	1.499	(38.08)	1.499	(38.08)	1.499	(38.08)	1.999	(50.78)
BB		1.000	(25.40)	1.125	(28.58)	1.125	(28.58)	1.375	(34.93)
C	Std.	.375	(9.53)	.375	(9.53)	.375	(9.53)	.500	(12.70)
	O.S.	.500	(12.70)	.500	(12.70)	.500	(12.70)	.625	(15.88)
CC	Std.	1/2 - 20		1/2 - 20		1/2 - 20		7/8 - 14	
	O.S.	7/8 - 14		7/8 - 14		7/8 - 14		1-1/4 - 12	
D	Std.	.500	(12.70)	.500	(12.70)	.500	(12.70)	.875	(22.23)
	O.S.	.813	(20.64)	.813	(20.64)	.813	(20.64)	1.125	(28.58)
DD		1/4 - 28		5/16 - 24		5/16 - 24		3/8 - 24	
E		2.000	(50.80)	2.500	(63.50)	3.000	(76.20)	3.750	(95.25)
EE		.375	(9.53)	.375	(9.53)	.375	(9.53)	.500	(12.70)
F		.375	(9.53)	.375	(9.53)	.375	(9.53)	.625	(15.88)
FF	Std.	5/8 - 18		5/8 - 18		5/8 - 18		1 - 14	
	O.S.	1 - 14		1 - 14		1 - 14		1-3/8 - 12	
G		1.500	(38.10)	1.500	(38.10)	1.500	(38.10)	1.750	(44.45)
J		1.000	(25.40)	1.000	(25.40)	1.000	(25.40)	1.250	(31.75)
K		.250	(6.35)	.313	(7.94)	.313	(7.94)	.375	(9.53)
KK	Std.	7/16 - 20		7/16 - 20		7/16 - 20		3/4 - 16	
	O.S.	3/4 - 16		3/4 - 16		3/4 - 16		1 - 14	
LB		3.625	(92.08)	3.625	(92.08)	3.750	(95.25)	4.250	(107.95)
MM	Std.	.625	(15.88)	.625	(15.88)	.625	(15.88)	1.000	(25.40)
	O.S.	1.000	(25.40)	1.000	(25.40)	1.000	(25.40)	1.375	(34.93)
P		2.313	(58.74)	2.313	(58.74)	2.438	(61.91)	2.625	(66.68)
R		1.428	(36.27)	1.838	(46.68)	2.192	(55.67)	2.758	(70.05)
VF	Std.	.625	(15.88)	.625	(15.88)	.625	(15.88)	.875	(22.23)
	O.S.	.875	(22.23)	.875	(22.23)	.875	(22.23)	1.000	(25.40)
WF	Std.	1.000	(25.40)	1.000	(25.40)	1.000	(25.40)	1.375	(34.93)
	O.S.	1.375	(34.93)	1.375	(34.93)	1.375	(34.93)	1.625	(41.28)
Y	Std.	1.875	(47.63)	1.875	(47.63)	1.875	(47.63)	2.438	(61.91)
	O.S.	2.250	(57.15)	2.250	(57.15)	2.250	(57.15)	2.688	(68.26)
ZB	Std.	4.875	(123.83)	4.938	(125.41)	5.063	(128.59)	6.000	(152.40)
	O.S.	5.250	(133.35)	5.313	(134.94)	5.438	(138.11)	6.250	(158.75)

**BB dimension on 8 bore is from the head.

All dimensions in inches (mm)

Series Q6/NQ Mounting Styles and Installation Dimensions

Recommended Torques for Tightening Tie Rods

CYLINDER BORE	SERIES Q6 STEEL TIE ROD	SERIES NQ STAINLESS TIE ROD
1-1/2"	6.6 ft. lbs.	3.75 ft. lbs.
2"	11 ft. lbs.	7.5 ft. lbs.
2-1/2"	13 ft. lbs.	7.5 ft. lbs.
3-3/4"	20 ft. lbs.	14 ft. lbs.
4"	24 ft. lbs.	14 ft. lbs.
5"	40 ft. lbs.	33 ft. lbs.
6"	48 ft. lbs.	33 ft. lbs.
7" & 8"	100 ft. lbs.	65 ft. lbs.

Codes NS Cap (MX2), MS Head (MX3), & LS Both Ends (MX1)

Extended Tie Rod Mounts

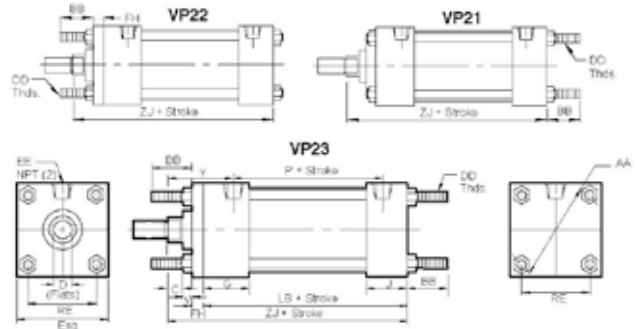

4" BORE (101.60)		5" BORE (127.00)		6" BORE (152.40)		7" BORE (177.80)		8" BORE (203.20)	
1"	(25.40)	1"	(25.40)	1-3/8"	(34.93)	1-3/8"	(34.93)	1-3/8"	(34.93)
1-3/8"	(34.93)	1-3/8"	(34.93)	1-3/4"	(44.45)	1-3/4"	(44.45)	1-3/4"	(44.45)
1.125	(28.58)	1.125	(28.58)	1.625	(41.28)	1.625	(41.28)	1.625	(41.28)
1.625	(41.28)	1.625	(41.28)	2.000	(50.80)	2.000	(50.80)	2.000	(50.80)
1.499	(38.08)	1.499	(38.08)	1.999	(50.78)	1.999	(50.78)	1.999	(50.78)
1.999	(50.78)	1.999	(50.78)	2.374	(60.30)	2.374	(60.30)	2.374	(60.30)
1.375	(34.93)	1.813	(46.04)	1.813	(46.04)	2.313	(58.74)	2.313	(58.74)
.500	(12.70)	.500	(12.70)	.625	(15.88)	.625	(15.88)	.625	(15.88)
.625	(15.88)	.625	(15.88)	.750	(19.05)	.750	(19.05)	.750	(19.05)**
7/8 - 14		7/8 - 14		1-1/4 - 12		1-1/4 - 12		1-1/4 - 12	
1-1/4 - 12		1-1/4 - 12		1-1/2 - 12		1-1/2 - 12		1-1/2 - 12	
.875	(22.23)	.875	(22.23)	1.125	(15.88)	1.125	(15.88)	1.125	(15.88)
1.125	(28.58)	1.125	(28.58)	1.500	(38.10)	1.500	(38.10)	1.500	(38.10)
3/8 - 24		1/2 - 20		1/2 - 20		5/8 - 18		5/8 - 18	
4.500	(114.30)	5.500	(139.70)	6.500	(165.10)	7.500	(190.50)	8.500	(215.90)
.500	(12.70)	.500	(12.70)	.750	(19.05)	.750	(19.05)	.750	(19.05)
.625	(15.88)	.625	(15.88)	.750	(19.05)	.750	(19.05)	.750	(19.05)
1 - 14		1 - 14		1-3/8 - 12		1-3/8 - 12		1-3/8 - 12	
1-3/8 - 12		1-3/8 - 12		1-3/4 - 12		1-3/4 - 12		1-3/4 - 12	
1.750	(44.45)	1.750	(44.45)	2.000	(50.80)	2.000	(50.80)	2.000	(50.80)
1.250	(31.75)	1.250	(31.75)	1.500	(38.10)	1.500	(38.10)	1.500	(38.10)
.375	(9.53)	.438	(11.11)	.438	(11.11)	.563	(14.29)	.563	(14.29)
3/4 - 16		3/4 - 16		1 - 14		1 - 14		1 - 14	
1 - 14		1 - 14		1-1/4 - 12		1-1/4 - 12		1-1/4 - 12	
4.250	(107.95)	4.500	(114.30)	5.000	(127.00)	5.125	(130.18)	5.125	(130.18)
1.000	(25.40)	1.000	(25.40)	1.375	(34.93)	1.375	(34.93)	1.375	(34.93)
1.375	(34.93)	1.375	(34.93)	1.750	(44.45)	1.750	(44.45)	1.750	(44.45)
2.625	(66.68)	2.875	(73.03)	3.125	(79.38)	3.250	(82.55)	3.250	(82.55)
3.323	(84.40)	4.101	(104.16)	4.879	(123.92)	5.730	(145.54)	6.442	(163.63)
.875	(22.23)	.875	(22.23)	1.000	(25.40)	1.000	(25.40)	1.000	(25.40)
1.000	(25.40)	1.000	(25.40)	1.125	(28.58)	1.125	(28.58)	1.125	(28.58)
1.375	(34.93)	1.375	(34.93)	1.625	(41.28)	1.625	(41.28)	1.625	(41.28)
1.625	(41.28)	1.625	(41.28)	1.875	(47.63)	1.875	(47.63)	1.875	(47.63)
2.438	(61.91)	2.438	(61.91)	2.813	(71.44)	2.813	(71.44)	2.813	(71.44)
2.688	(68.26)	2.688	(68.26)	3.063	(77.79)	3.063	(77.79)	3.063	(77.79)
6.000	(152.40)	6.313	(160.34)	7.063	(179.39)	7.313	(185.74)	7.313	(185.74)
6.250	(158.75)	6.563	(166.69)	7.313	(185.74)	7.563	(192.09)	7.563	(192.09)

**BB dimension on 8 bore is from the head.

All dimensions in inches (mm)

NOTE

For strokes in excess of 30 inches, see "Stop Tube Selection" on page 45.

The force on the rod should be perpendicular to the mounting surface and coincide with the centerline of the piston rod. For eccentric loads, the larger of the two available rods in each bore size is recommended. Stop tubes should also be considered.

Series Q6/NQ Mounting Styles and Installation Dimensions

The basic cylinder is often used by customers who have designed their own method of mounting. These mounting methods may include custom made mounting flanges, machining into the end caps, and clamping mechanisms to

secure the cylinder. Consult Eaton engineering when using the cylinder in this fashion.

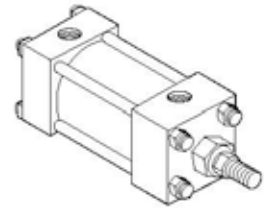

Code KS No Mount Cylinder

(ANSI MX0)

DIMENSION		1 1/2" BORE (38.10)		2" BORE (50.80)		2 1/2" BORE (63.50)		3 1/4" BORE (82.55)		
Rod	Std.	5/8"	(15.88)	5/8"	(15.88)	5/8"	(15.88)	1"	(25.40)	
	O.S.	1"	(25.40)	1"	(25.40)	1"	(25.40)	1-3/8"	(34.93)	
A	Std.	.750	(19.05)	.750	(19.05)	.750	(19.05)	1.125	(28.58)	
	O.S.	1.125	(28.58)	1.125	(28.58)	1.125	(28.58)	1.625	(41.28)	
B +.000										
	-.002	Std.	1.124	(28.55)	1.124	(28.55)	1.124	(28.55)	1.499	(38.08)
		O.S.	1.499	(38.08)	1.499	(38.08)	1.499	(38.08)	1.999	(50.78)
C	Std.	.375	(9.53)	.375	(9.53)	.375	(9.53)	.500	(12.70)	
	O.S.	.500	(12.70)	.500	(12.70)	.500	(12.70)	.625	(15.88)	
CC	Std.	1/2 - 20		1/2 - 20		1/2 - 20		7/8 - 14		
	O.S.	7/8 - 14		7/8 - 14		7/8 - 14		1-1/4 - 12		
D	Std.	.500	(12.70)	.500	(12.70)	.500	(12.70)	.875	(22.23)	
	O.S.	.813	(20.64)	.813	(20.64)	.813	(20.64)	1.125	(28.58)	
E		2.000	(50.80)	2.500	(63.50)	3.000	(76.20)	3.750	(95.25)	
EE		.375	(9.53)	.375	(9.53)	.375	(9.53)	.500	(12.70)	
FF	Std.	5/8 - 18		5/8 - 18		5/8 - 18		1 - 14		
	O.S.	1 - 14		1 - 14		1 - 14		1-3/8 - 12		
G		1.500	(38.10)	1.500	(38.10)	1.500	(38.10)	1.750	(44.45)	
J		1.000	(25.40)	1.000	(25.40)	1.000	(25.40)	1.250	(31.75)	
K		.250	(6.35)	.313	(7.94)	.313	(7.94)	.375	(9.53)	
KK	Std.	7/16 - 20		7/16 - 20		7/16 - 20		3/4 - 16		
	O.S.	3/4 - 16		3/4 - 16		3/4 - 16		1 - 14		
LB		3.625	(92.08)	3.625	(92.08)	3.750	(95.25)	4.250	(107.95)	
MM	Std.	.625	(15.88)	.625	(15.88)	.625	(15.88)	1.000	(25.40)	
	O.S.	1.000	(25.40)	1.000	(25.40)	1.000	(25.40)	1.375	(34.93)	
P		2.313	(58.74)	2.313	(58.74)	2.438	(61.91)	2.625	(66.68)	
R		1.428	(36.27)	1.838	(46.68)	2.192	(55.67)	2.758	(70.05)	
VF	Std.	.625	(15.88)	.625	(15.88)	.625	(15.88)	.875	(22.23)	
	O.S.	.875	(22.23)	.875	(22.23)	.875	(22.23)	1.000	(25.40)	
WF	Std.	1.000	(25.40)	1.000	(25.40)	1.000	(25.40)	1.375	(34.93)	
	O.S.	1.375	(34.93)	1.375	(34.93)	1.375	(34.93)	1.625	(41.28)	
Y	Std.	1.875	(47.63)	1.875	(47.63)	1.875	(47.63)	2.438	(61.91)	
	O.S.	2.250	(57.15)	2.250	(57.15)	2.250	(57.15)	2.688	(68.26)	
ZB	Std.	4.875	(123.83)	4.938	(125.41)	5.063	(128.59)	6.000	(152.40)	
	O.S.	5.250	(133.35)	5.313	(134.94)	5.438	(138.11)	6.250	(158.75)	

All dimensions in inches (mm)

Series Q6/NQ Mounting Styles and Installation Dimensions

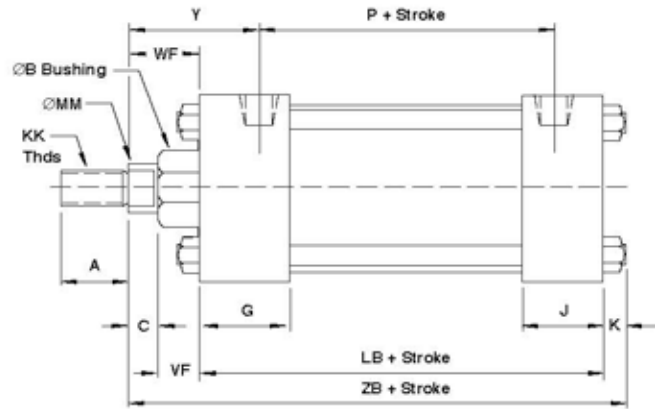
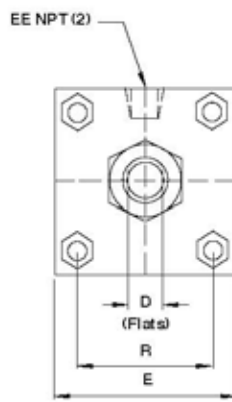

Code KS No Mount Cylinder
(ANSI MX0)

4" BORE (101.60)		5" BORE (127.00)		6" BORE (152.40)		7" BORE (177.80)		8" BORE (203.20)	
1"	(25.40)	1"	(25.40)	1-3/8"	(34.93)	1-3/8"	(34.93)	1-3/8"	(34.93)
1-3/8"	(34.93)	1-3/8"	(34.93)	1-3/4"	(44.45)	1-3/4"	(44.45)	1-3/4"	(44.45)
1.125	(28.58)	1.125	(28.58)	1.625	(41.28)	1.625	(41.28)	1.625	(41.28)
1.625	(41.28)	1.625	(41.28)	2.000	(50.80)	2.000	(50.80)	2.000	(50.80)
1.499	(38.08)	1.499	(38.08)	1.999	(50.78)	1.999	(50.78)	1.999	(50.78)
1.999	(50.78)	1.999	(50.78)	2.374	(60.30)	2.374	(60.30)	2.374	(60.30)
.500	(12.70)	.500	(12.70)	.625	(15.88)	.625	(15.88)	.625	(15.88)
.625	(15.88)	.625	(15.88)	.750	(19.05)	.750	(19.05)	.750	(19.05)
7/8 - 14		7/8 - 14		1-1/4 - 12		1-1/4 - 12		1-1/4 - 12	
1-1/4 - 12		1-1/4 - 12		1-1/2 - 12		1-1/2 - 12		1-1/2 - 12	
.875	(22.23)	.875	(22.23)	1.125	(15.88)	1.125	(15.88)	1.125	(15.88)
1.125	(28.58)	1.125	(28.58)	1.500	(38.10)	1.500	(38.10)	1.500	(38.10)
4.500	(114.30)	5.500	(139.70)	6.500	(165.10)	7.500	(190.50)	8.500	(215.90)
.500	(12.70)	.500	(12.70)	.750	(19.05)	.750	(19.05)	.750	(19.05)
1 - 14		1 - 14		1-3/8 - 12		1-3/8 - 12		1-3/8 - 12	
1-3/8 - 12		1-3/8 - 12		1-3/4 - 12		1-3/4 - 12		1-3/4 - 12	
1.750	(44.45)	1.750	(44.45)	2.000	(50.80)	2.000	(50.80)	2.000	(50.80)
1.250	(31.75)	1.250	(31.75)	1.500	(38.10)	1.500	(38.10)	1.500	(38.10)
.375	(9.53)	.438	(11.11)	.438	(11.11)	.563	(14.29)	.563	(14.29)
3/4 - 16		3/4 - 16		1 - 14		1 - 14		1 - 14	
1 - 14		1 - 14		1-1/4 - 12		1-1/4 - 12		1-1/4 - 12	
4.250	(107.95)	4.500	(114.30)	5.000	(127.00)	5.125	(130.18)	5.125	(130.18)
1.000	(25.40)	1.000	(25.40)	1.375	(34.93)	1.375	(34.93)	1.375	(34.93)
1.375	(34.93)	1.375	(34.93)	1.750	(44.45)	1.750	(44.45)	1.750	(44.45)
2.625	(66.68)	2.875	(73.03)	3.125	(79.38)	3.250	(82.55)	3.250	(82.55)
3.323	(84.40)	4.101	(104.16)	4.879	(123.92)	5.730	(145.54)	6.442	(163.63)
.875	(22.23)	.875	(22.23)	1.000	(25.40)	1.000	(25.40)	1.000	(25.40)
1.000	(25.40)	1.000	(25.40)	1.125	(28.58)	1.125	(28.58)	1.125	(28.58)
1.375	(34.93)	1.375	(34.93)	1.625	(41.28)	1.625	(41.28)	1.625	(41.28)
1.625	(41.28)	1.625	(41.28)	1.875	(47.63)	1.875	(47.63)	1.875	(47.63)
2.438	(61.91)	2.438	(61.91)	2.813	(71.44)	2.813	(71.44)	2.813	(71.44)
2.688	(68.26)	2.688	(68.26)	3.063	(77.79)	3.063	(77.79)	3.063	(77.79)
6.000	(152.40)	6.313	(160.34)	7.063	(179.39)	7.313	(185.74)	7.313	(185.74)
6.250	(158.75)	6.563	(166.69)	7.313	(185.74)	7.563	(192.09)	7.563	(192.09)

All dimensions in inches (mm)

NOTE

For strokes in excess of 30 inches, see "Stop Tube Selection" on page 45.

Series Q6/NQ Mounting Styles and Installation Dimensions

Double rod cylinders are specified when equal displacement is desired on both sides of the piston, or when the application is such that another function can be performed simultaneously with a second rod. The single

rod mount application data is also applicable to double rod cylinders.

Rod and pilot related dimensions are typical for both ends.

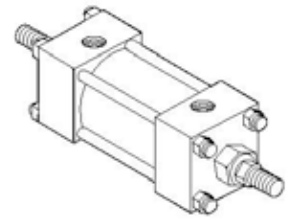

Code KD Double Rod, No Mount

DIMENSION		1 1/2" BORE (38.10)		2" BORE (50.80)		2 1/2" BORE (63.50)		3 1/4" BORE (82.55)	
Rod	Std.	5/8"	(15.88)	5/8"	(15.88)	5/8"	(15.88)	1"	(25.40)
	O.S.	1"	(25.40)	1"	(25.40)	1"	(25.40)	1-3/8"	(34.93)
A	Std.	.750	(19.05)	.750	(19.05)	.750	(19.05)	1.125	(28.58)
	O.S.	1.125	(28.58)	1.125	(28.58)	1.125	(28.58)	1.625	(41.28)
B	+ .000								
	-.002	Std.	1.124	(28.55)	1.124	(28.55)	1.124	(28.55)	1.499
	O.S.	1.499	(38.08)	1.499	(38.08)	1.499	(38.08)	1.999	(50.78)
C	Std.	.375	(9.53)	.375	(9.53)	.375	(9.53)	.500	(12.70)
	O.S.	.500	(12.70)	.500	(12.70)	.500	(12.70)	.625	(15.88)
CC	Std.	1/2 - 20		1/2 - 20		1/2 - 20		7/8 - 14	
	O.S.	7/8 - 14		7/8 - 14		7/8 - 14		1-1/4 - 12	
D	Std.	.500	(12.70)	.500	(12.70)	.500	(12.70)	.875	(22.23)
	O.S.	.875	(22.23)	.813	(20.64)	.813	(20.64)	1.125	(28.58)
E		2.000	(50.80)	2.500	(63.50)	3.000	(76.20)	3.750	(95.25)
EE		.375	(9.53)	.375	(9.53)	.375	(9.53)	.500	(12.70)
FF	Std.	5/8 - 18		5/8 - 18		5/8 - 18		1 - 14	
	O.S.	1 - 14		1 - 14		1 - 14		1-3/8 - 12	
G		1.500	(38.10)	1.500	(38.10)	1.500	(38.10)	1.750	(44.45)
J		1.000	(25.40)	1.000	(25.40)	1.000	(25.40)	1.250	(31.75)
K		.250	(6.35)	.313	(7.94)	.313	(7.94)	.375	(9.53)
KK	Std.	7/16 - 20		7/16 - 20		7/16 - 20		3/4 - 16	
	O.S.	3/4 - 16		3/4 - 16		3/4 - 16		1 - 14	
LB		3.625	(92.08)	3.625	(92.08)	3.750	(95.25)	4.250	(107.95)
MM	Std.	.625	(15.88)	.625	(15.88)	.625	(15.88)	1.000	(25.40)
	O.S.	1.000	(25.40)	1.000	(25.40)	1.000	(25.40)	1.375	(34.93)
P		2.313	(58.74)	2.313	(58.74)	2.438	(61.91)	2.625	(66.68)
R		1.428	(36.27)	1.838	(46.68)	2.192	(55.67)	2.758	(70.05)
VF	Std.	.625	(15.88)	.625	(15.88)	.625	(15.88)	.875	(22.23)
	O.S.	.875	(22.23)	.875	(22.23)	.875	(22.23)	1.000	(25.40)
WF	Std.	1.000	(25.40)	1.000	(25.40)	1.000	(25.40)	1.375	(34.93)
	O.S.	1.375	(34.93)	1.375	(34.93)	1.375	(34.93)	1.625	(41.28)
Y	Std.	1.875	(47.63)	1.875	(47.63)	1.875	(47.63)	2.438	(61.91)
	O.S.	2.250	(57.15)	2.250	(57.15)	2.250	(57.15)	2.688	(68.26)
ZL	Std.	5.375	(136.53)	5.438	(138.11)	5.563	(141.29)	6.500	(165.10)
	O.S.	6.125	(155.58)	6.125	(155.58)	6.250	(158.75)	7.500	(190.50)
ZM	O.S.	6.875	(174.63)	6.875	(174.63)	7.000	(177.80)	8.000	(203.20)

All dimensions in inches (mm)

Series Q6/NQ Mounting Styles and Installation Dimensions

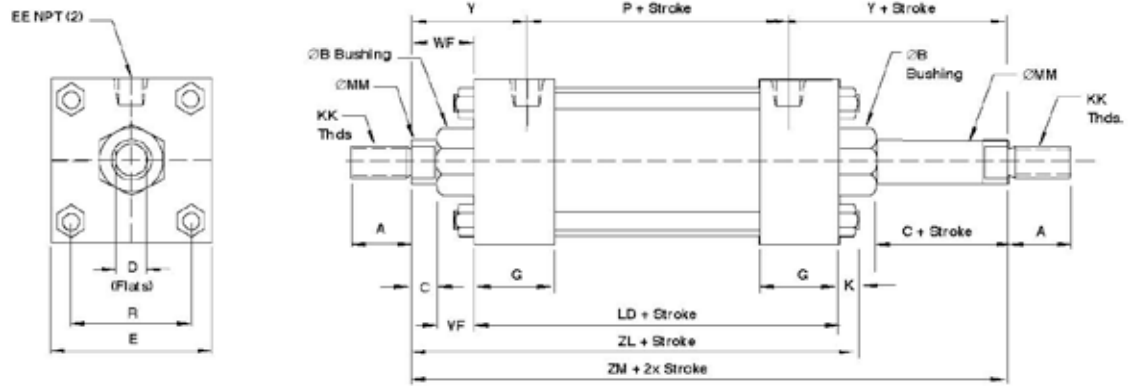

**Code KD Double Rod,
No Mount**

4" BORE (101.60)		5" BORE (127.00)		6" BORE (152.40)		7" BORE (177.80)		8" BORE (203.20)	
1"	(25.40)	1"	(25.40)	1-3/8"	(34.93)	1-3/8"	(34.93)	1-3/8"	(34.93)
1-3/8"	(34.93)	1-3/8"	(34.93)	1-3/4"	(44.45)	1-3/4"	(44.45)	1-3/4"	(44.45)
1.125	(28.58)	1.125	(28.58)	1.625	(41.28)	1.625	(41.28)	1.625	(41.28)
1.625	(41.28)	1.625	(41.28)	2.000	(50.80)	2.000	(50.80)	2.000	(50.80)
<hr/>									
1.499	(38.08)	1.499	(38.08)	1.999	(50.78)	1.999	(50.78)	1.999	(50.78)
1.999	(50.78)	1.999	(50.78)	2.374	(60.30)	2.374	(60.30)	2.374	(60.30)
.500	(12.70)	.500	(12.70)	.625	(15.88)	.625	(15.88)	.625	(15.88)
.625	(15.88)	.625	(15.88)	.750	(19.05)	.750	(19.05)	.750	(19.05)
7/8 - 14		7/8 - 14		1-1/4 - 12		1-1/4 - 12		1-1/4 - 12	
1-1/4 - 12		1-1/4 - 12		1-1/2 - 12		1-1/2 - 12		1-1/2 - 12	
.875	(22.23)	.875	(22.23)	1.125	(28.58)	1.125	(28.58)	1.125	(28.58)
1.125	(28.58)	1.125	(28.58)	1.500	(38.10)	1.500	(38.10)	1.500	(38.10)
4.500	(114.30)	5.500	(139.70)	6.500	(165.10)	7.500	(190.50)	8.500	(215.90)
.500	(12.70)	.500	(12.70)	.750	(19.05)	.750	(19.05)	.750	(19.05)
1 - 14		1 - 14		1-3/8 - 12		1-3/8 - 12		1-3/8 - 12	
1-3/8 - 12		1-3/8 - 12		1-3/4 - 12		1-3/4 - 12		1-3/4 - 12	
1.750	(44.45)	1.750	(44.45)	2.000	(50.80)	2.000	(50.80)	2.000	(50.80)
1.250	(31.75)	1.250	(31.75)	1.500	(38.10)	1.500	(38.10)	1.500	(38.10)
.375	(9.53)	.438	(11.11)	.438	(11.11)	.563	(14.29)	.563	(14.29)
3/4 - 16		3/4 - 16		1 - 14		1 - 14		1 - 14	
1 - 14		1 - 14		1-1/4 - 12		1-1/4 - 12		1-1/4 - 12	
4.250	(107.95)	4.500	(114.30)	5.000	(127.00)	5.125	(130.18)	5.125	(130.18)
1.000	(25.40)	1.000	(25.40)	1.375	(34.93)	1.375	(34.93)	1.375	(34.93)
1.375	(34.93)	1.375	(34.93)	1.750	(44.45)	1.750	(44.45)	1.750	(44.45)
2.625	(66.68)	2.875	(73.03)	3.125	(79.38)	3.250	(82.55)	3.250	(82.55)
3.323	(84.40)	4.101	(104.16)	4.879	(123.92)	5.730	(145.54)	6.442	(163.63)
.875	(22.23)	.875	(22.23)	1.000	(25.40)	1.000	(25.40)	1.000	(25.40)
1.000	(25.40)	1.000	(25.40)	1.125	(28.58)	1.125	(28.58)	1.125	(28.58)
1.375	(34.93)	1.375	(34.93)	1.625	(41.28)	1.625	(41.28)	1.625	(41.28)
1.625	(41.28)	1.625	(41.28)	1.875	(47.63)	1.875	(47.63)	1.875	(47.63)
2.438	(61.91)	2.438	(61.91)	2.813	(71.44)	2.813	(71.44)	2.813	(71.44)
2.688	(68.26)	2.688	(68.26)	3.063	(77.79)	3.063	(77.79)	3.063	(77.79)
6.500	(165.10)	6.813	(174.04)	7.563	(192.09)	7.813	(198.44)	7.813	(198.44)
7.500	(190.50)	7.500	(190.50)	8.750	(222.25)	8.875	(225.43)	8.875	(225.43)
8.000	(203.20)	8.000	(203.20)	9.250	(234.95)	9.375	(238.13)	9.375	(238.13)

All dimensions in inches (mm)

Series Q6/NQ Mounting Styles and Installation Dimensions

Angle mounts are for moving loads along a flat guided surface as in a carriage along rails. The mounting surface should be flat and parallel to the centerline of the piston rod.

The load should be guided to traverse along the centerline of the piston rod. The frame on which the cylinder is mounted must be sufficiently rigid to resist bending moments.

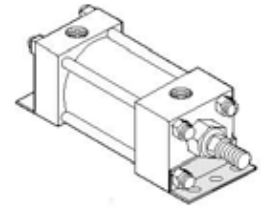

Code YY Angle Mounts (ANSI MS1)

DIMENSION		1 1/2" BORE (38.10)		2" BORE (50.80)		2 1/2" BORE (63.50)		3 1/4" BORE (82.55)	
Rod	Std.	5/8"	(15.88)	5/8"	(15.88)	5/8"	(15.88)	1"	(25.40)
	O.S.	1"	(25.40)	1"	(25.40)	1"	(25.40)	1-3/8"	(34.93)
A	Std.	.750	(19.05)	.750	(19.05)	.750	(19.05)	1.125	(28.58)
	O.S.	1.125	(28.58)	1.125	(28.58)	1.125	(28.58)	1.625	(41.28)
AB		.438	(11.11)	.438	(11.11)	.438	(11.11)	.563	(14.29)
AH		1.188	(30.16)	1.438	(36.51)	1.625	(41.28)	1.938	(49.21)
AL		1.000	(25.40)	1.000	(25.40)	1.000	(25.40)	1.250	(31.75)
AO		.375	(9.53)	.375	(9.53)	.375	(9.53)	.500	(12.70)
AT		.125	(3.18)	.125	(3.18)	.125	(3.18)	.125	(3.18)
+.000									
-.002B	Std.	1.124	(28.55)	1.124	(28.55)	1.124	(28.55)	1.499	(38.08)
	O.S.	1.499	(38.08)	1.499	(38.08)	1.499	(38.08)	1.999	(50.78)
C	Std.	.375	(9.53)	.375	(9.53)	.375	(9.53)	.500	(12.70)
	O.S.	.500	(12.70)	.500	(12.70)	.500	(12.70)	.625	(15.88)
CC	Std.	1/2 - 20		1/2 - 20		1/2 - 20		7/8 - 14	
	O.S.	7/8 - 14		7/8 - 14		7/8 - 14		1-1/4 - 12	
D	Std.	.500	(12.70)	.500	(12.70)	.500	(12.70)	.813	(20.64)
	O.S.	.813	(20.64)	.813	(20.64)	.813	(20.64)	1.125	(28.58)
E		2.000	(50.80)	2.500	(63.50)	3.000	(76.20)	3.750	(95.25)
EE		.375	(9.53)	.375	(9.53)	.375	(9.53)	.500	(12.70)
FF	Std.	5/8 - 18		5/8 - 18		5/8 - 18		1 - 14	
	O.S.	1 - 14		1 - 14		1 - 14		1-3/8 - 12	
G		1.500	(38.10)	1.500	(38.10)	1.500	(38.10)	1.750	(44.45)
J		1.000	(25.40)	1.000	(25.40)	1.000	(25.40)	1.250	(31.75)
K		.250	(6.35)	.313	(7.94)	.313	(7.94)	.375	(9.53)
KK	Std.	7/16 - 20		7/16 - 20		7/16 - 20		3/4 - 16	
	O.S.	3/4 - 16		3/4 - 16		3/4 - 16		1 - 14	
LB		3.625	(92.08)	3.625	(92.08)	3.750	(95.25)	4.250	(107.95)
MM	Std.	.625	(15.88)	.625	(15.88)	.625	(15.88)	1.000	(25.40)
	O.S.	1.000	(25.40)	1.000	(25.40)	1.000	(25.40)	1.375	(34.93)
NF		1.375	(34.93)	1.375	(34.93)	1.375	(34.93)	1.875	(47.63)
P		2.313	(58.74)	2.313	(58.74)	2.438	(61.91)	2.625	(66.68)
R		1.428	(36.27)	1.838	(46.68)	2.192	(55.67)	2.758	(70.05)
S		1.250	(31.75)	1.750	(44.45)	2.250	(57.15)	2.750	(69.85)
SA		6.000	(152.40)	6.000	(152.40)	6.125	(155.58)	7.375	(187.33)
VF	Std.	.625	(15.88)	.625	(15.88)	.625	(15.88)	.875	(22.23)
	O.S.	.875	(22.23)	.875	(22.23)	.875	(22.23)	1.000	(25.40)
WF	Std.	1.000	(25.40)	1.000	(25.40)	1.000	(25.40)	1.375	(34.93)
	O.S.	1.375	(34.93)	1.375	(34.93)	1.375	(34.93)	1.625	(41.28)
XA	Std.	5.625	(142.88)	5.438	(138.11)	5.750	(146.05)	6.875	(174.63)
	O.S.	6.000	(152.40)	6.000	(152.40)	6.125	(155.58)	7.125	(180.98)
Y	Std.	1.875	(47.63)	1.875	(47.63)	1.875	(47.63)	2.438	(61.91)
	O.S.	2.250	(57.15)	2.250	(57.15)	2.250	(57.15)	2.688	(68.26)

All dimensions in inches (mm)

Series Q6/NQ Mounting Styles and Installation Dimensions

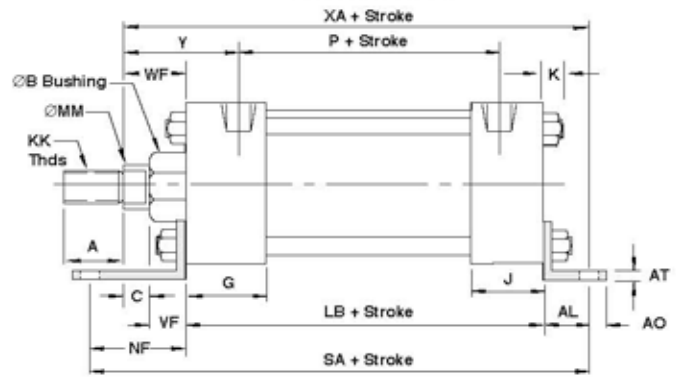
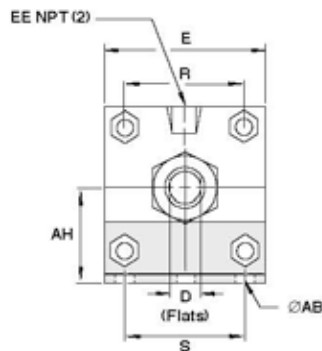

Code YY Angle Mounts (ANSI MS1)

4" BORE (101.60)		5" BORE (127.00)		6" BORE (152.40)		7" BORE (177.80)		8" BORE (203.20)	
1"	(25.40)	1"	(25.40)	1-3/8"	(34.93)	1-3/8"	(34.93)	1-3/8"	(34.93)
1-3/8"	(34.93)	1-3/8"	(34.93)	1-3/4"	(44.45)	1-3/4"	(44.45)	1-3/4"	(44.45)
1.125	(28.58)	1.125	(28.58)	1.625	(41.28)	1.625	(41.28)	1.625	(41.28)
1.625	(41.28)	1.625	(41.28)	2.000	(50.80)	2.000	(50.80)	2.000	(50.80)
.563	(14.29)	.688	(17.46)	.813	(20.64)	.813	(20.64)	.813	(20.64)
2.250	(57.15)	2.750	(69.85)	3.250	(82.55)	3.750	(95.25)	4.250	(107.95)
1.250	(31.75)	1.375	(34.93)	1.375	(34.93)	1.813	(46.04)	1.813	(46.04)
.500	(12.70)	.625	(15.88)	.625	(15.88)	.688	(17.46)	.688	(17.46)
.125	(3.18)	.187	(4.75)	.187	(4.75)	.250	(6.35)	.250	(6.35)
1.499	(38.08)	1.499	(38.08)	1.999	(50.78)	1.999	(50.78)	1.999	(50.78)
1.999	(50.78)	1.999	(50.78)	2.374	(60.30)	2.374	(60.30)	2.374	(60.30)
.500	(12.70)	.500	(12.70)	.625	(15.88)	.625	(15.88)	.625	(15.88)
.625	(15.88)	.625	(15.88)	.750	(19.05)	.750	(19.05)	.750	(19.05)
7/8 - 14		7/8 - 14		1-1/4 - 12		1-1/4 - 12		1-1/4 - 12	
1-1/4 - 12		1-1/4 - 12		1-1/2 - 12		1-1/2 - 12		1-1/2 - 12	
.813	(20.64)	.813	(20.64)	1.125	(28.58)	1.125	(28.58)	1.125	(28.58)
1.125	(28.58)	1.125	(28.58)	1.500	(38.10)	1.500	(38.10)	1.500	(38.10)
4.500	(114.30)	5.500	(139.70)	6.500	(165.10)	7.500	(190.50)	8.500	(215.90)
.500	(12.70)	.500	(12.70)	.750	(19.05)	.750	(19.05)	.750	(19.05)
1 - 14		1 - 14		1-3/8 - 12		1-3/8 - 12		1-3/8 - 12	
1-3/8 - 12		1-3/8 - 12		1-3/4 - 12		1-3/4 - 12		1-3/4 - 12	
1.750	(44.45)	1.750	(44.45)	2.000	(50.80)	2.000	(50.80)	2.000	(50.80)
1.250	(31.75)	1.250	(31.75)	1.500	(38.10)	1.500	(38.10)	1.500	(38.10)
.375	(9.53)	.438	(11.11)	.438	(11.11)	.563	(14.29)	.563	(14.29)
3/4 - 16		3/4 - 16		1 - 14		1 - 14		1 - 14	
1 - 14		1 - 14		1-1/4 - 12		1-1/4 - 12		1-1/4 - 12	
4.250	(107.95)	4.500	(114.30)	5.000	(127.00)	5.125	(130.18)	5.125	(130.18)
1.000	(25.40)	1.000	(25.40)	1.375	(34.93)	1.375	(34.93)	1.375	(34.93)
1.375	(34.93)	1.375	(34.93)	1.750	(44.45)	1.750	(44.45)	1.750	(44.45)
1.875	(47.63)	2.000	(50.80)	2.125	(53.98)	1.813	(46.04)	1.813	(46.04)
2.625	(66.68)	2.875	(73.03)	3.125	(79.38)	3.250	(82.55)	3.250	(82.55)
3.323	(84.40)	4.101	(104.16)	4.879	(123.92)	5.730	(145.54)	6.442	(163.63)
3.500	(88.90)	4.250	(107.95)	5.250	(133.35)	6.125	(155.58)	7.125	(180.98)
7.375	(187.33)	7.875	(200.03)	8.500	(215.90)	8.750	(222.25)	8.750	(222.25)
.875	(22.23)	.875	(22.23)	1.000	(25.40)	1.000	(25.40)	1.000	(25.40)
1.000	(25.40)	1.000	(25.40)	1.125	(28.58)	1.125	(28.58)	1.125	(28.58)
1.375	(34.93)	1.375	(34.93)	1.625	(41.28)	1.625	(41.28)	1.625	(41.28)
1.625	(41.28)	1.625	(41.28)	1.875	(47.63)	1.875	(47.63)	1.875	(47.63)
5.875	(149.63)	7.250	(184.15)	8.000	(203.20)	8.562	(217.47)	8.562	(217.47)
7.125	(180.98)	7.500	(190.50)	8.250	(209.55)	8.813	(223.84)	8.813	(223.84)
2.438	(61.91)	2.438	(61.91)	2.813	(71.44)	2.813	(71.44)	2.813	(71.44)
2.688	(68.26)	2.688	(68.26)	3.063	(77.79)	3.063	(77.79)	3.063	(77.79)

All dimensions in inches (mm)

NOTE

Limit operating pressure to 400 psi (27 bar) non-shock hydraulic for minimum deflection.

For strokes in excess of 30 inches, see "Stop Tube Selection" on page 45.

For applications with unsupported loads, the bearing must absorb more force. The larger available rod is recommended, and stop tubes should be considered.

Series Q6/NQ Mounting Styles and Installation Dimensions

These mounts can be used both in compression (push) and tension (pull). Care must be exercised to prevent rod buckling in compression applications with long strokes.

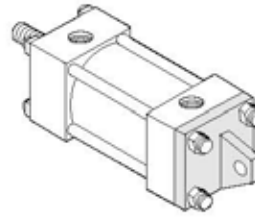

Code DE Detachable Eye Mounts (MP4)

DIMENSION		1 1/2" BORE (38.10)		2" BORE (50.80)		2 1/2" BORE (63.50)		3 1/4" BORE (82.55)	
Rod	Std.	5/8"	(15.88)	5/8"	(15.88)	5/8"	(15.88)	1"	(25.40)
	O.S.	1"	(25.40)	1"	(25.40)	1"	(25.40)	1-3/8"	(34.93)
A	Std.	.750	(19.05)	.750	(19.05)	.750	(19.05)	1.125	(28.58)
	O.S.	1.125	(28.58)	1.125	(28.58)	1.125	(28.58)	1.625	(41.28)
B +.000									
	-.002 Std.	1.124	(28.55)	1.124	(28.55)	1.124	(28.55)	1.499	(38.08)
	O.S.	1.499	(38.08)	1.499	(38.08)	1.499	(38.08)	1.999	(50.78)
C	Std.	.375	(9.53)	.375	(9.53)	.375	(9.53)	.500	(12.70)
	O.S.	.500	(12.70)	.500	(12.70)	.500	(12.70)	.625	(15.88)
CB		.750	(19.05)	.750	(19.05)	.750	(19.05)	1.250	(31.75)
CC	Std.	1/2 - 20		1/2 - 20		1/2 - 20		7/8 - 14	
	O.S.	7/8 - 14		7/8 - 14		7/8 - 14		1-1/4 - 12	
D	Std.	.500	(12.70)	.500	(12.70)	.500	(12.70)	.813	(20.64)
	O.S.	.813	(20.64)	.813	(20.64)	.813	(20.64)	1.125	(28.58)
E		2.000	(50.80)	2.500	(63.50)	3.000	(76.20)	3.750	(95.25)
EE		.375	(9.53)	.375	(9.53)	.375	(9.53)	.500	(12.70)
FF	Std.	5/8 - 18		5/8 - 18		5/8 - 18		1 - 14	
	O.S.	1 - 14		1 - 14		1 - 14		1-3/8 - 12	
FL		1.125	(28.58)	1.125	(28.58)	1.125	(28.58)	1.875	(47.63)
G		1.500	(38.10)	1.500	(38.10)	1.500	(38.10)	1.750	(44.45)
J		1.000	(25.40)	1.000	(25.40)	1.000	(25.40)	1.250	(31.75)
K		.250	(6.35)	.313	(7.94)	.313	(7.94)	.375	(9.53)
KK	Std.	7/16 - 20		7/16 - 20		7/16 - 20		3/4 - 16	
	O.S.	3/4 - 16		3/4 - 16		3/4 - 16		1 - 14	
L		.750	(19.05)	.750	(19.05)	.750	(19.05)	1.250	(31.75)
LB		3.625	(92.08)	3.625	(92.08)	3.750	(95.25)	4.250	(107.95)
LR		.750	(19.05)	.750	(19.05)	.750	(19.05)	1.250	(31.75)
M		.500	(12.70)	.500	(12.70)	.500	(12.70)	.750	(19.05)
MM	Std.	.625	(15.88)	.625	(15.88)	.625	(15.88)	1.000	(25.40)
	O.S.	1.000	(25.40)	1.000	(25.40)	1.000	(25.40)	1.375	(34.93)
MR		.625	(15.88)	.625	(15.88)	.625	(15.88)	.938	(23.81)
P		2.313	(58.74)	2.313	(58.74)	2.438	(61.91)	2.625	(66.68)
VF	Std.	.625	(15.88)	.625	(15.88)	.625	(15.88)	.875	(22.23)
	O.S.	.875	(22.23)	.875	(22.23)	.875	(22.23)	1.000	(25.40)
WF	Std.	1.000	(25.40)	1.000	(25.40)	1.000	(25.40)	1.375	(34.93)
	O.S.	1.375	(34.93)	1.375	(34.93)	1.375	(34.93)	1.625	(41.28)
XD	Std.	5.750	(146.05)	5.750	(146.05)	5.875	(149.23)	7.500	(190.50)
	O.S.	6.125	(155.58)	6.125	(155.58)	6.250	(158.75)	7.750	(196.85)
Y	Std.	1.875	(47.63)	1.875	(47.63)	1.875	(47.63)	2.438	(61.91)
	O.S.	2.250	(57.15)	2.250	(57.15)	2.250	(57.15)	2.688	(68.26)

All dimensions in inches (mm)

Series Q6/NQ Mounting Styles and Installation Dimensions

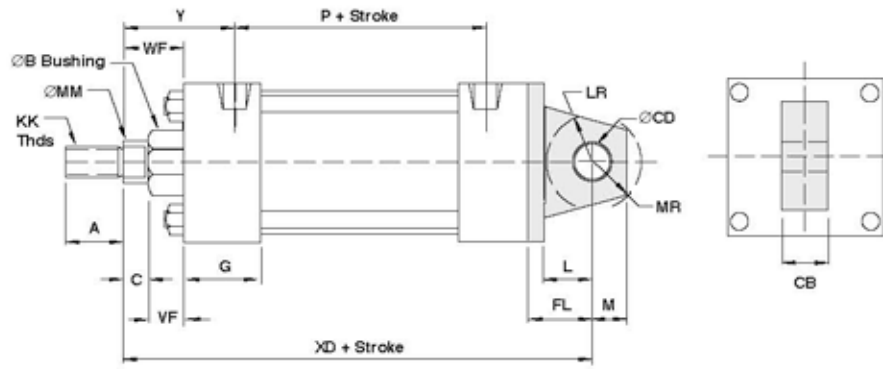

Code DE Detachable Eye Mounts (MP4)

4" BORE (101.60)		5" BORE (127.00)		6" BORE (152.40)		7" BORE (177.80)		8" BORE (203.20)	
1"	(25.40)	1"	(25.40)	1-3/8"	(34.93)	1-3/8"	(34.93)	1-3/8"	(34.93)
1-3/8"	(34.93)	1-3/8"	(34.93)	1-3/4"	(44.45)	1-3/4"	(44.45)	1-3/4"	(44.45)
1.125	(28.58)	1.125	(28.58)	1.625	(41.28)	1.625	(41.28)	1.625	(41.28)
1.625	(41.28)	1.625	(41.28)	2.000	(50.80)	2.000	(50.80)	2.000	(50.80)
1.499	(38.08)	1.499	(38.08)	1.999	(50.78)	1.999	(50.78)	1.999	(50.78)
1.999	(50.78)	1.999	(50.78)	2.374	(60.30)	2.374	(60.30)	2.374	(60.30)
.500	(12.70)	.500	(12.70)	.625	(15.88)	.625	(15.88)	.625	(15.88)
.625	(15.88)	.625	(15.88)	.750	(19.05)	.750	(19.05)	.750	(19.05)
1.250	(31.75)	1.250	(31.75)	1.500	(38.10)	1.500	(38.10)	1.500	(38.10)
7/8 - 14		7/8 - 14		1-1/4 - 12		1-1/4 - 12		1-1/4 - 12	
1-1/4 - 12		1-1/4 - 12		1-1/2 - 12		1-1/2 - 12		1-1/2 - 12	
.813	(20.64)	.813	(20.64)	1.125	(28.58)	1.125	(28.58)	1.125	(28.58)
1.125	(28.58)	1.125	(28.58)	1.500	(38.10)	1.500	(38.10)	1.500	(38.10)
4.500	(114.30)	5.500	(139.70)	6.500	(165.10)	7.500	(190.50)	8.500	(215.90)
.500	(12.70)	.500	(12.70)	.750	(19.05)	.750	(19.05)	.750	(19.05)
1 - 14		1 - 14		1-3/8 - 12		1-3/8 - 12		1-3/8 - 12	
1-3/8 - 12		1-3/8 - 12		1-3/4 - 12		1-3/4 - 12		1-3/4 - 12	
1.875	(47.63)	1.875	(47.63)	2.250	(57.15)	2.250	(57.15)	2.250	(57.15)
1.750	(44.45)	1.750	(44.45)	2.000	(50.80)	2.000	(50.80)	2.000	(50.80)
1.250	(31.75)	1.250	(31.75)	1.500	(38.10)	1.500	(38.10)	1.500	(38.10)
.375	(9.53)	.438	(11.11)	.438	(11.11)	.563	(14.29)	.563	(14.29)
3/4 - 16		3/4 - 16		1 - 14		1 - 14		1 - 14	
1 - 14		1 - 14		1-1/4 - 12		1-1/4 - 12		1-1/4 - 12	
1.250	(31.75)	1.250	(31.75)	1.500	(38.10)	1.500	(38.10)	1.500	(38.10)
4.250	(107.95)	4.500	(114.30)	5.000	(127.00)	5.125	(130.18)	5.125	(130.18)
1.250	(31.75)	1.250	(31.75)	1.500	(38.10)	1.500	(38.10)	1.500	(38.10)
.750	(19.05)	.750	(19.05)	1.000	(25.40)	1.000	(25.40)	1.000	(25.40)
1.000	(25.40)	1.000	(25.40)	1.375	(34.93)	1.375	(34.93)	1.375	(34.93)
1.375	(34.93)	1.375	(34.93)	1.750	(44.45)	1.750	(44.45)	1.750	(44.45)
.938	(23.81)	.938	(23.81)	1.188	(30.16)	1.188	(30.16)	1.188	(30.16)
2.625	(66.68)	2.875	(73.03)	3.125	(79.38)	3.250	(82.55)	3.250	(82.55)
.875	(22.23)	.875	(22.23)	1.000	(25.40)	1.000	(25.40)	1.000	(25.40)
1.000	(25.40)	1.000	(25.40)	1.125	(28.58)	1.125	(28.58)	1.125	(28.58)
1.375	(34.93)	1.375	(34.93)	1.625	(41.28)	1.625	(41.28)	1.625	(41.28)
1.625	(41.28)	1.625	(41.28)	1.875	(47.63)	1.875	(47.63)	1.875	(47.63)
7.500	(190.50)	7.750	(196.85)	8.875	(225.43)	9.000	(228.60)	9.000	(228.60)
7.750	(196.85)	8.000	(203.20)	9.125	(231.78)	9.250	(234.95)	9.250	(234.95)
2.438	(61.91)	2.438	(61.91)	2.813	(71.44)	2.813	(71.44)	2.813	(71.44)
2.688	(68.26)	2.688	(68.26)	3.063	(77.79)	3.063	(77.79)	3.063	(77.79)

All dimensions in inches (mm)

NOTE

For strokes in excess of 30 inches, see "Stop Tube Selection" on page 45.

The centerline of the machine member that attaches to the swivel pin must be perpendicular to the centerline of the piston rod and the curved path must be in one place only. any misalignment will cause excess side loading on the bearing and piston. This could lead to premature failure.

Series Q6/NQ Mounting Styles and Installation Dimensions

These mounts can be used both in compression (push) and tension (pull). Care must be exercised to prevent rod buckling in compression applications with long strokes.

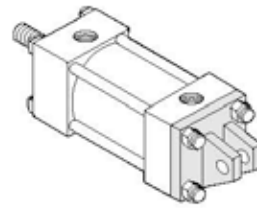

Code DC Detachable Clevis (MP2)

DIMENSION		1 1/2" BORE (38.10)		2" BORE (50.80)		2 1/2" BORE (63.50)		3 1/4" BORE (82.55)	
Rod	Std.	5/8"	(15.88)	5/8"	(15.88)	5/8"	(15.88)	1"	(25.40)
	O.S.	1"	(25.40)	1"	(25.40)	1"	(25.40)	1-3/8"	(34.93)
A	Std.	.750	(19.05)	.750	(19.05)	.750	(19.05)	1.125	(28.58)
	O.S.	1.125	(28.58)	1.125	(28.58)	1.125	(28.58)	1.625	(41.28)
B +.000									
	Std.	1.124	(28.55)	1.124	(28.55)	1.124	(28.55)	1.499	(38.08)
	O.S.	1.499	(38.08)	1.499	(38.08)	1.499	(38.08)	1.999	(50.78)
C	Std.	.375	(9.53)	.375	(9.53)	.375	(9.53)	.500	(12.70)
	O.S.	.500	(12.70)	.500	(12.70)	.500	(12.70)	.625	(15.88)
CB		.750	(19.05)	.750	(19.05)	.750	(19.05)	1.250	(31.75)
CC	Std.	1/2 - 20		1/2 - 20		1/2 - 20		7/8 - 14	
	O.S.	7/8 - 14		7/8 - 14		7/8 - 14		1-1/4 - 12	
CD		.500	(12.70)	.500	(12.70)	.500	(12.70)	.750	(19.05)
CW		.500	(12.70)	.500	(12.70)	.500	(12.70)	.625	(15.88)
D	Std.	.500	(12.70)	.500	(12.70)	.500	(12.70)	.813	(20.64)
	O.S.	.813	(20.64)	.813	(20.64)	.813	(20.64)	1.125	(28.58)
E		2.000	(50.80)	2.500	(63.50)	3.000	(76.20)	3.750	(95.25)
EE		.375	(9.53)	.375	(9.53)	.375	(9.53)	.500	(12.70)
FF	Std.	5/8 - 18		5/8 - 18		5/8 - 18		1 - 14	
	O.S.	1 - 14		1 - 14		1 - 14		1-3/8 - 12	
FL		1.125	(28.58)	1.125	(28.58)	1.125	(28.58)	1.875	(47.63)
G		1.500	(38.10)	1.500	(38.10)	1.500	(38.10)	1.750	(44.45)
J		1.000	(25.40)	1.000	(25.40)	1.000	(25.40)	1.250	(31.75)
K		.250	(6.35)	.313	(7.94)	.313	(7.94)	.375	(9.53)
KK	Std.	7/16 - 20		7/16 - 20		7/16 - 20		3/4 - 16	
	O.S.	3/4 - 16		3/4 - 16		3/4 - 16		1 - 14	
L		.750	(19.05)	.750	(19.05)	.750	(19.05)	1.250	(31.75)
LB		3.625	(92.08)	3.625	(92.08)	3.750	(95.25)	4.250	(107.95)
LR		.750	(19.05)	.750	(19.05)	.750	(19.05)	1.250	(31.75)
M		.500	(12.70)	.500	(12.70)	.500	(12.70)	.750	(19.05)
MM	Std.	.625	(15.88)	.625	(15.88)	.625	(15.88)	1.000	(25.40)
	O.S.	1.000	(25.40)	1.000	(25.40)	1.000	(25.40)	1.375	(34.93)
MR		.625	(15.88)	.625	(15.88)	.625	(15.88)	.938	(23.81)
P		2.313	(58.74)	2.313	(58.74)	2.438	(61.91)	2.625	(66.68)
VF	Std.	.625	(15.88)	.625	(15.88)	.625	(15.88)	.875	(22.23)
	O.S.	.875	(22.23)	.875	(22.23)	.875	(22.23)	1.000	(25.40)
WF	Std.	1.000	(25.40)	1.000	(25.40)	1.000	(25.40)	1.375	(34.93)
	O.S.	1.375	(34.93)	1.375	(34.93)	1.375	(34.93)	1.625	(41.28)
XD	Std.	5.750	(146.05)	5.750	(146.05)	5.875	(149.23)	7.500	(190.50)
	O.S.	6.125	(155.58)	6.125	(155.58)	6.250	(158.75)	7.750	(196.85)
Y	Std.	1.875	(47.63)	1.875	(47.63)	1.875	(47.63)	2.438	(61.91)
	O.S.	2.250	(57.15)	2.250	(57.15)	2.250	(57.15)	2.688	(68.26)

All dimensions in inches (mm)

Series Q6/NQ Mounting Styles and Installation Dimensions

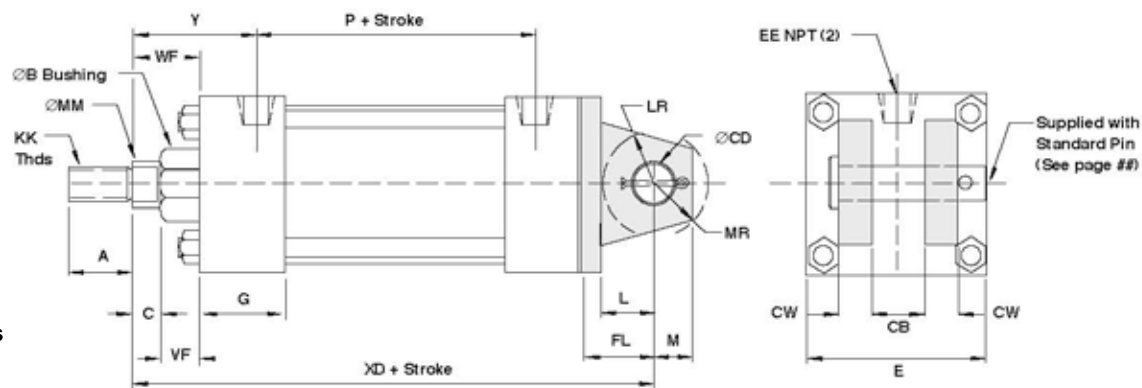

Code DC Detachable Clevis (MP2)

4" BORE (101.60)		5" BORE (127.00)		6" BORE (152.40)		7" BORE (177.80)		8" BORE (203.20)	
1"	(25.40)	1"	(25.40)	1-3/8"	(34.93)	1-3/8"	(34.93)	1-3/8"	(34.93)
1-3/8"	(34.93)	1-3/8"	(34.93)	1-3/4"	(44.45)	1-3/4"	(44.45)	1-3/4"	(44.45)
1.125	(28.58)	1.125	(28.58)	1.625	(41.28)	1.625	(41.28)	1.625	(41.28)
1.625	(41.28)	1.625	(41.28)	2.000	(50.80)	2.000	(50.80)	2.000	(50.80)
1.499	(38.08)	1.499	(38.08)	1.999	(50.78)	1.999	(50.78)	1.999	(50.78)
1.999	(50.78)	1.999	(50.78)	2.374	(60.30)	2.374	(60.30)	2.374	(60.30)
.500	(12.70)	.500	(12.70)	.625	(15.88)	.625	(15.88)	.625	(15.88)
.625	(15.88)	.625	(15.88)	.750	(19.05)	.750	(19.05)	.750	(19.05)
1.250	(31.75)	1.250	(31.75)	1.500	(38.10)	1.500	(38.10)	1.500	(38.10)
7/8 - 14		7/8 - 14		1-1/4 - 12		1-1/4 - 12		1-1/4 - 12	
1-1/4 - 12		1-1/4 - 12		1-1/2 - 12		1-1/2 - 12		1-1/2 - 12	
.750	(19.05)	.750	(19.05)	1.000	(25.40)	1.000	(25.40)	1.000	(25.40)
.625	(15.88)	.625	(15.88)	.750	(19.05)	.750	(19.05)	.750	(19.05)
.813	(20.64)	.813	(20.64)	1.125	(28.58)	1.125	(28.58)	1.125	(28.58)
1.125	(28.58)	1.125	(28.58)	1.500	(38.10)	1.500	(38.10)	1.500	(38.10)
4.500	(114.30)	5.500	(139.70)	6.500	(165.10)	7.500	(190.50)	8.500	(215.90)
.500	(12.70)	.500	(12.70)	.750	(19.05)	.750	(19.05)	.750	(19.05)
1 - 14		1 - 14		1-3/8 - 12		1-3/8 - 12		1-3/8 - 12	
1-3/8 - 12		1-3/8 - 12		1-3/4 - 12		1-3/4 - 12		1-3/4 - 12	
1.875	(47.63)	1.875	(47.63)	2.250	(57.15)	2.250	(57.15)	2.250	(57.15)
1.750	(44.45)	1.750	(44.45)	2.000	(50.80)	2.000	(50.80)	2.000	(50.80)
1.250	(31.75)	1.250	(31.75)	1.500	(38.10)	1.500	(38.10)	1.500	(38.10)
.375	(9.53)	.438	(11.11)	.438	(11.11)	.563	(14.29)	.563	(14.29)
3/4 - 16		3/4 - 16		1 - 14		1 - 14		1 - 14	
1 - 14		1 - 14		1-1/4 - 12		1-1/4 - 12		1-1/4 - 12	
1.250	(31.75)	1.250	(31.75)	1.500	(38.10)	1.500	(38.10)	1.500	(38.10)
4.250	(107.95)	4.500	(114.30)	5.000	(127.00)	5.125	(130.18)	5.125	(130.18)
1.250	(31.75)	1.250	(31.75)	1.500	(38.10)	1.500	(38.10)	1.500	(38.10)
.750	(19.05)	.750	(19.05)	1.000	(25.40)	1.000	(25.40)	1.000	(25.40)
1.000	(25.40)	1.000	(25.40)	1.375	(34.93)	1.375	(34.93)	1.375	(34.93)
1.375	(34.93)	1.375	(34.93)	1.750	(44.45)	1.750	(44.45)	1.750	(44.45)
.938	(23.81)	.938	(23.81)	1.188	(30.16)	1.188	(30.16)	1.188	(30.16)
2.625	(66.68)	2.875	(73.03)	3.125	(79.38)	3.250	(82.55)	3.250	(82.55)
.875	(22.23)	.875	(22.23)	1.000	(25.40)	1.000	(25.40)	1.000	(25.40)
1.000	(25.40)	1.000	(25.40)	1.125	(28.58)	1.125	(28.58)	1.125	(28.58)
1.375	(34.93)	1.375	(34.93)	1.625	(41.28)	1.625	(41.28)	1.625	(41.28)
1.625	(41.28)	1.625	(41.28)	1.875	(47.63)	1.875	(47.63)	1.875	(47.63)
7.500	(190.50)	7.750	(196.85)	8.875	(225.43)	9.000	(228.60)	9.000	(228.60)
7.750	(196.85)	8.000	(203.20)	9.125	(231.78)	9.250	(234.95)	9.250	(234.95)
2.438	(61.91)	2.438	(61.91)	2.813	(71.44)	2.813	(71.44)	2.813	(71.44)
2.688	(68.26)	2.688	(68.26)	3.063	(77.79)	3.063	(77.79)	3.063	(77.79)

All dimensions in inches (mm)

NOTE

For strokes in excess of 30 inches, see "Stop Tube Selection" on page 45.

The centerline of the machine member that attaches to the swivel pin must be perpendicular to the centerline of the piston rod and the curved path must be in one place only. Any misalignment will cause excess side loading on the bearing and piston. This could lead to premature failure.

Series Q6/NQ Accessories for 1-1/2 thru 8 inch Bore Cylinders

NFPA Rod Clevis

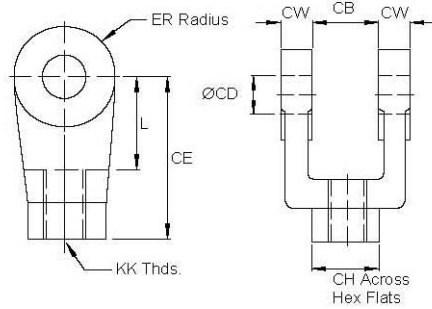

	Q662008A	Q662008B	Q66200CA	Q662010A	Q662016A
CB	.750 (19.05)	.750 (19.05)	1.250 (31.75)	1.500 (38.10)	2.000 (50.80)
CD	.500 (12.70)	.500 (12.70)	.750 (19.05)	1.000 (25.40)	1.375 (60.33)
CE	1.500 (38.10)	1.500 (38.10)	2.375 (60.33)	3.125 (79.38)	4.125 (104.78)
CH	1.000 (25.40)	1.000 (25.40)	1.250 (31.75)	1.500 (38.10)	2.000 (50.80)
CW	.500 (12.70)	.500 (12.70)	.625 (15.88)	.750 (19.05)	1.000 (25.40)
ER	.500 (12.70)	.500 (12.70)	.750 (19.05)	1.000 (25.40)	1.375 (60.33)
KK	7/16-20	1/2-20	3/4-16	1-14	1-1/4-12
L	.750 (19.05)	.750 (19.05)	1.250 (31.75)	1.500 (38.10)	2.125 (53.98)

Small Rod Clevis & Jam Nut

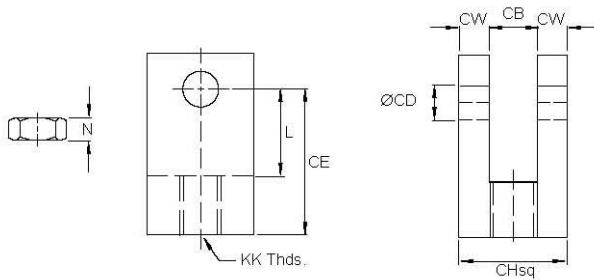

	Q662008C	Q66200CC
CB	.500 (12.70)	.750 (19.05)
CD	.500 (12.70)	.750 (19.05)
CE	1.375 (34.93)	1.750 (44.45)
CH	1.000 (25.40)	1.500 (38.10)
CW	.250 (6.35)	.375 (9.53)
KK	1/2-20	3/4-16
L	.750 (19.05)	1.000 (25.40)
N	.375 (9.53)	.500 (12.70)

NFPA Rod Eye

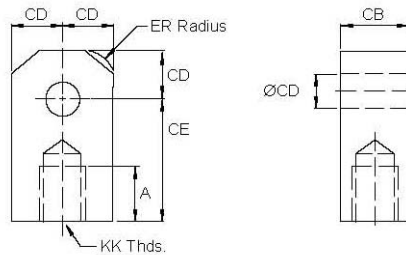

	Q660008A	Q660008C	Q66000CA	Q660010A	Q660016A
CB	.750 (19.05)	.750 (19.05)	1.250 (31.75)	1.500 (38.10)	2.000 (50.80)
CD	.500 (12.70)	.500 (12.70)	.750 (19.05)	1.000 (25.40)	1.375 (60.33)
CE	1.500 (38.10)	1.500 (38.10)	2.375 (60.33)	3.125 (79.38)	4.125 (104.78)
ER	.500 (12.70)	.500 (12.70)	.750 (19.05)	1.000 (25.40)	1.375 (60.33)
L	.750 (19.05)	.750 (19.05)	1.250 (31.75)	1.500 (38.10)	2.125 (53.98)

Spherical Rod Eye

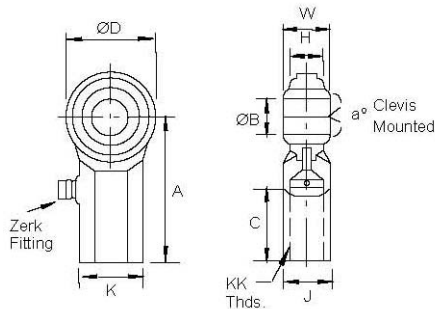

	Q662008C	Q66200CC	Q660010B
Bore	1-1/2 & 2-1/2	3-1/4, 4 & 5	6 & 8
a° Misalign. Angle	12	14	14
A ± .015	2.125 (53.98)	2.875 (73.03)	4.125 (104.78)
B +.0025 / -.0005	.500 (12.70)	.750 (19.05)	1.000 (25.40)
C +.062 / -.031	1.062 (26.97)	1.562 (39.67)	2.125 (53.98)
D ± .010	1.312 (33.32)	1.750 (44.45)	2.750 (69.85)
H REF.	.453 (11.51)	.593 (15.06)	1.000 (25.40)
J ± .010	.750 (19.05)	1.000 (25.40)	1.500 (38.10)
K ± .010	.875 (22.23)	1.125 (28.58)	1.625 (41.28)
KK UNF-2B	1/2-20	3/4-16	1-14
W +.000 / -.005	.625 (15.88)	.875 (22.23)	1.375 (34.93)

Series Q6/NQ Accessories for 1-1/2 thru 8 inch Bore Cylinders

NFPA Eye Bracket

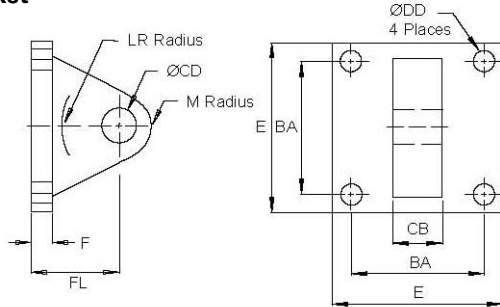

	Q662008A	Q662008B	Q66200CA	Q662010A
BA	1.625 (41.28)	2.562 (65.07)	3.250 (82.55)	3.812 (96.82)
CB	.750 (19.05)	1.250 (31.75)	1.500 (38.10)	2.000 (50.80)
CD	.500 (12.70)	.750 (19.05)	1.000 (25.40)	1.375 (60.33)
DD	.406 (10.31)	.531 (13.49)	.656 (16.66)	.656 (16.66)
E	2.500 (63.50)	3.500 (88.90)	4.500 (114.30)	5.000 (127.00)
F	.375 (9.53)	.625 (15.88)	.750 (19.05)	.875 (22.23)
FL	1.125 (28.58)	1.875 (47.63)	2.250 (57.15)	3.000 (76.20)
LR	.750 (19.05)	1.250 (31.75)	1.500 (38.10)	2.125 (53.98)

Alternate Eye Bracket

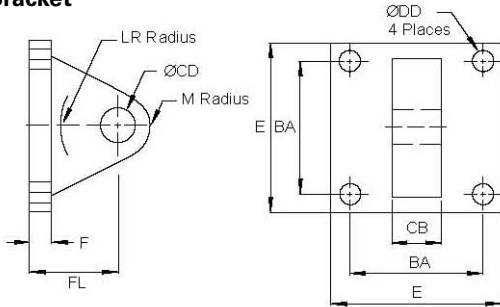

	Q678008B	Q678008C	Q678008D	Q67800CB	Q67800CC
BA	1.437 (36.50)	1.844 (46.84)	2.187 (55.55)	2.937 (74.60)	3.562 (90.47)
CB	.750 (19.05)	.750 (19.05)	.750 (19.05)	1.250 (31.75)	1.250 (31.75)
CD	.500 (12.70)	.500 (12.70)	.500 (12.70)	.750 (19.05)	.750 (19.05)
DD	.281 (7.14)	.343 (8.71)	.343 (8.71)	.469 (11.91)	.469 (11.91)
E	2.000 (50.80)	2.500 (63.50)	3.000 (76.20)	3.750 (95.25)	4.500 (114.30)
F	.375 (9.53)	.375 (9.53)	.375 (9.53)	.500 (12.70)	.500 (12.70)
FL	1.125 (28.58)	1.125 (28.58)	1.125 (28.58)	1.750 (44.45)	1.750 (44.45)
LR	.562 (14.27)	.562 (14.27)	.562 (14.27)	1.000 (25.40)	1.000 (25.40)
M	.625 (15.88)	.625 (15.88)	.625 (15.88)	.875 (22.23)	.875 (22.23)

NFPA Clevis Bracket

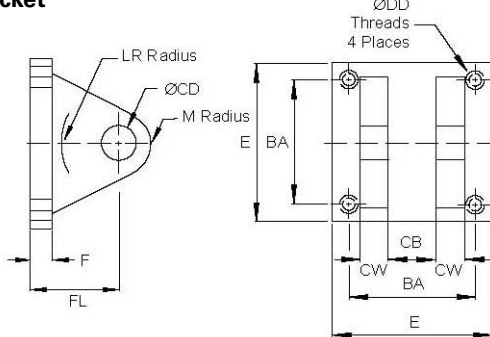

	Q661008A	Q66100CA	Q661010A
BA	1.625 (41.28)	2.562 (65.07)	3.250 (82.55)
CB	.750 (19.05)	1.250 (31.75)	1.500 (38.10)
CD	.500 (12.70)	.750 (19.05)	1.000 (25.40)
CW	.500 (12.70)	.625 (15.88)	.750 (19.05)
DD	3/8 - 24	1/2 - 20	5/8 - 18
E	2.500 (63.50)	3.500 (88.90)	4.500 (114.30)
F	.375 (9.53)	.625 (15.88)	.750 (19.05)
FL	1.125 (28.58)	1.875 (47.63)	2.250 (57.15)
LR	.750 (19.05)	1.250 (31.75)	1.500 (38.10)
M	.500 (12.70)	.812 (20.62)	1.000 (25.40)

NFPA Pin

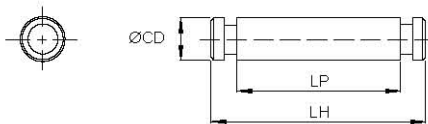

	Q683008A	Q68300CA	Q683010A
CD	.500 (12.70)	.750 (19.05)	1.000 (25.40)
LH	2.219 (56.36)	3.125 (79.38)	3.750 (95.25)
LP	1.875 (47.63)	2.750 (69.85)	3.250 (82.55)

Alternate Eye Bracket

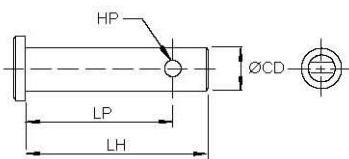

	Q683008B	Q683008C	Q683008CB	Q68300CC	Q683010B	Q683016B
CD	.500 (12.70)	.500 (12.70)	.750 (19.05)	.750 (19.05)	1.000 (25.40)	1.375 (34.93)
HP	.156 (3.96)	.156 (3.96)	.156 (3.96)	.156 (3.96)	.203 (5.16)	.250 (6.35)
LH	1.421 (36.09)	2.250 (57.15)	2.000 (50.80)	3.000 (76.20)	3.500 (88.90)	5.000 (127.00)
LP	1.266 (32.16)	2.093 (53.16)	1.843 (46.81)	2.843 (72.21)	3.297 (83.74)	4.500 (114.30)

All dimensions in inches (mm)

Series Q6/NQ Rod Alignment Coupler

The Rod Alignment Coupler allows 1/16 inch of radial float and two inches of spherical movement. This prevents cylinder binding due to misalignment thus extending bearing and seal life, and permits greater tolerance between the centerline of the cylinder and mating part for simplified installation.

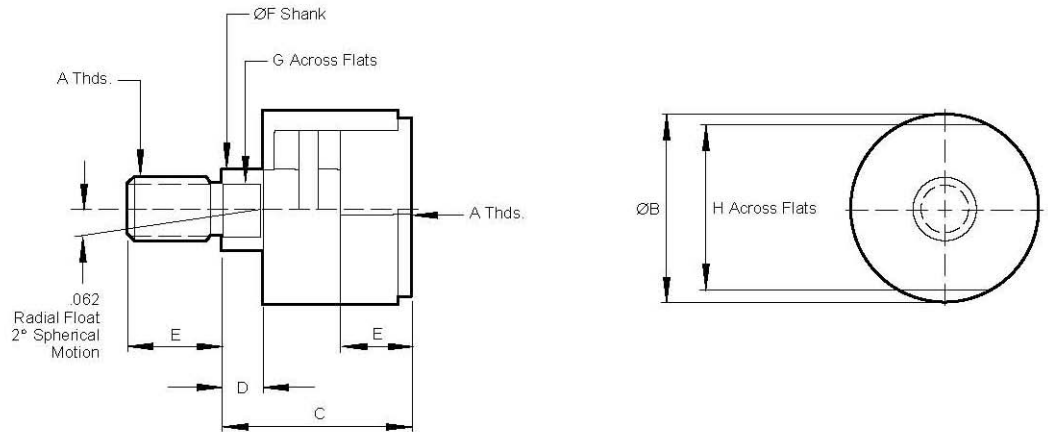

	7756A- 1/4-28	7756A- 5/16-24	7756A- 3/8-24	7756A- 7/16-20	7756A- 1/2-20	7756A- 5/8-18	7756A- 3/4-16	7756A- 7/8-14	7756A- 1-14	7756A- 1-1/4-12	7756A- 1-1/2-12	7756A- 1-3/4-12
A	1/4-28	5/16-24	3/8-24	7/16-20	1/2-20	5/8-18	3/4-16	7/8-14	1-14	1-1/4-12	1-1/2-12	1-3/4-12
B	.875 (22.23)	.875 (22.23)	.875 (22.23)	1.250 (31.75)	1.250 (31.75)	1.250 (31.75)	1.750 (44.45)	1.750 (44.45)	2.500 (63.50)	2.500 (63.50)	3.250 (82.50)	3.250 (82.50)
C	1.250 (31.75)	1.250 (31.75)	1.250 (31.75)	2.000 (50.80)	2.000 (50.80)	2.000 (50.80)	2.312 (58.72)	2.312 (58.72)	2.937 (74.60)	2.937 (74.60)	4.375 (111.13)	4.375 (111.13)
D	.250 (6.35)	.250 (6.35)	.250 (6.35)	.500 (12.70)	.500 (12.70)	.500 (12.70)	.500 (12.70)	.500 (12.70)	.500 (12.70)	.500 (12.70)	.812 (20.62)	.812 (20.62)
E	.625 (15.88)	.625 (15.88)	.625 (15.88)	.750 (19.05)	.750 (19.05)	.750 (19.05)	1.125 (28.58)	1.125 (28.58)	1.625 (41.28)	1.625 (41.28)	2.250 (57.15)	2.250 (57.15)
F	.312 (7.92)	.312 (7.92)	.375 (9.53)	.625 (15.88)	.625 (15.88)	.625 (15.88)	.969 (24.61)	.969 (24.61)	1.375 (34.93)	1.375 (34.93)	1.750 (44.45)	1.750 (44.45)
G	.187 (4.75)	.250 (6.35)	.312 (7.92)	.500 (12.70)	.500 (12.70)	.500 (12.70)	.812 (20.62)	.812 (20.62)	1.156 (29.36)	1.156 (29.36)	1.500 (38.10)	1.500 (38.10)
H	.750 (19.05)	.750 (19.05)	.750 (19.05)	1.125 (28.58)	1.125 (28.58)	1.125 (28.58)	1.500 (38.10)	1.500 (38.10)	2.250 (57.15)	2.250 (57.15)	3.000 (76.20)	3.000 (76.20)
Max Pull lbs. (kg)	1,500 (680)	2,075 (941)	2,075 (941)	2,500 (1134)	3,500 (1588)	4,750 (2155)	8,500 (3856)	9,750 (4423)	16,000 (7258)	19,500 (8845)	33,500 (15196)	33,500 (15196)

NOTE

A Rod Alignment Coupler is not recommended for unguided loads.

Series Q6/NQ Optional Rod Ends for 1-1/2 thru 8 inch Bore Cylinders

Rod End Types

In addition to selecting the correct bore, you must specify the appropriate rod size and rod end configuration for your application.

Five different inch rod end configurations are available. If a custom design is required, contact your local Eaton sales engineer, and define your requirements.

DIMENSION		1 1/2" BORE (38.10)		2" BORE (50.80)		2 1/2" BORE (63.50)		3 1/4" BORE (82.55)		
Rod	Std.	5/8"	(15.88)	5/8"	(15.88)	5/8"	(15.88)	1"	(25.40)	
	O.S.	1"	(25.40)	1"	(25.40)	1"	(25.40)	1-3/8"	(34.93)	
A	Std.	.750	(19.05)	.750	(19.05)	.750	(19.05)	1.125	(28.58)	
	O.S.	1.125	(28.58)	1.125	(28.58)	1.125	(28.58)	1.625	(41.28)	
B +.000										
	-.002	Std.	1.124	(28.55)	1.124	(28.55)	1.124	(28.55)	1.499	(38.08)
		O.S.	1.499	(38.08)	1.499	(38.08)	1.499	(38.08)	1.999	(50.78)
C	Std.	.375	(9.53)	.375	(9.53)	.375	(9.53)	.500	(12.70)	
	O.S.	.500	(12.70)	.500	(12.70)	.500	(12.70)	.625	(15.88)	
CC	Std.	1/2 - 20		1/2 - 20		1/2 - 20		7/8 - 14		
	O.S.	7/8 - 14		7/8 - 14		7/8 - 14		1-1/4 - 12		
D	Std.	.500	(12.70)	.500	(12.70)	.500	(12.70)	.813	(20.64)	
	O.S.	.813	(20.64)	.813	(20.64)	.813	(20.64)	1.125	(28.58)	
KK	Std.	7/16 - 20		7/16 - 20		7/16 - 20		3/4 - 16		
	O.S.	3/4 - 16		3/4 - 16		3/4 - 16		1 - 14		
VF	Std.	.625	(15.88)	.625	(15.88)	.625	(15.88)	.875	(22.23)	
	O.S.	.875	(22.23)	.875	(22.23)	.875	(22.23)	1.000	(25.40)	

All dimensions in inches (mm)

Series Q6/NQ Optional Rod Ends for 1-1/2 thru 8 inch Bore Cylinders

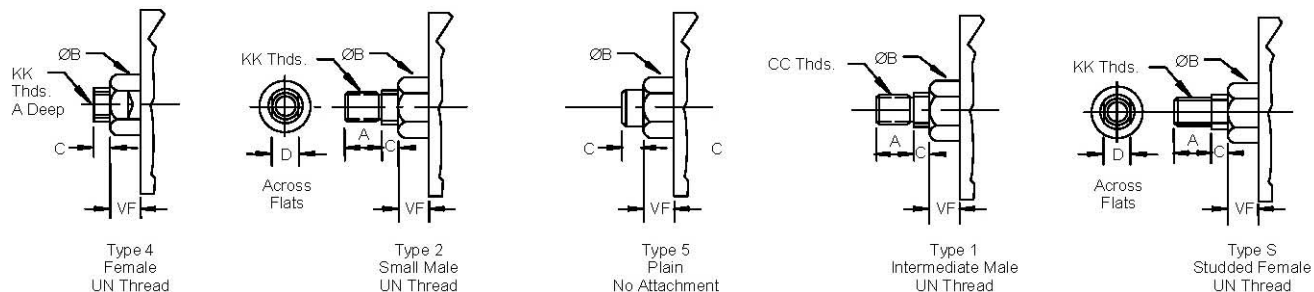

4" BORE (101.60)		5" BORE (127.00)		6" BORE (152.40)		7" BORE (177.80)		8" BORE (203.20)	
1"	(25.40)	1"	(25.40)	1-3/8"	(34.93)	1-3/8"	(34.93)	1-3/8"	(34.93)
1-3/8"	(34.93)	1-3/8"	(34.93)	1-3/4"	(44.45)	1-3/4"	(44.45)	1-3/4"	(44.45)
1.125	(28.58)	1.125	(28.58)	1.625	(41.28)	1.625	(41.28)	1.625	(41.28)
1.625	(41.28)	1.625	(41.28)	2.000	(50.80)	2.000	(50.80)	2.000	(50.80)
1.499	(38.08)	1.499	(38.08)	1.999	(50.78)	1.999	(50.78)	1.999	(50.78)
1.999	(50.78)	1.999	(50.78)	2.374	(60.30)	2.374	(60.30)	2.374	(60.30)
.500	(12.70)	.500	(12.70)	.625	(15.88)	.625	(15.88)	.625	(15.88)
.625	(15.88)	.625	(15.88)	.750	(19.05)	.750	(19.05)	.750	(19.05)
7/8 - 14		7/8 - 14		1-1/4 - 12		1-1/4 - 12		1-1/4 - 12	
1-1/4 - 12		1-1/4 - 12		1-1/2 - 12		1-1/2 - 12		1-1/2 - 12	
.813	(20.64)	.813	(20.64)	1.125	(28.58)	1.125	(28.58)	1.125	(28.58)
1.125	(28.58)	1.125	(28.58)	1.500	(38.10)	1.500	(38.10)	1.500	(38.10)
3/4 - 16		3/4 - 16		1 - 14		1 - 14		1 - 14	
1 - 14		1 - 14		1-1/4 - 12		1-1/4 - 12		1-1/4 - 12	
.875	(22.23)	.875	(22.23)	1.000	(25.40)	1.000	(25.40)	1.000	(25.40)
1.000	(25.40)	1.000	(25.40)	1.125	(28.58)	1.125	(28.58)	1.125	(28.58)

All dimensions in inches (mm)

Series Q6/NQ 3/4 & 1-1/8 inch Bore Cylinders and Mounts

Code EE Bolt Thru Mounts (ANSI MS8)

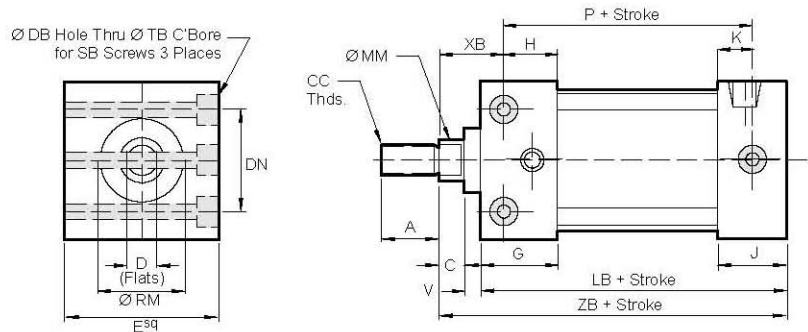
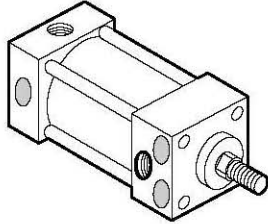

Code BS Tapped Mounts (ANSI MS9)

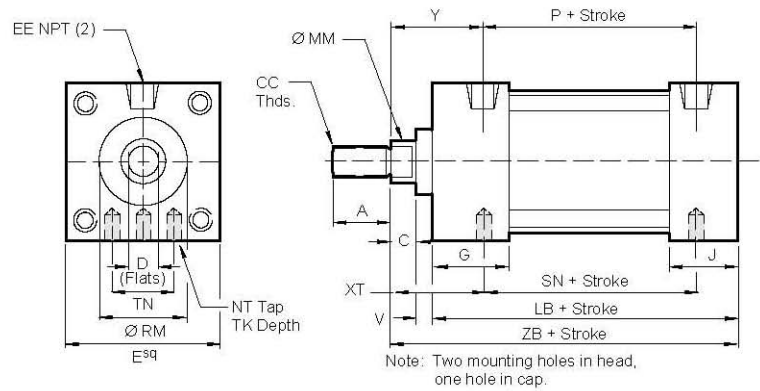
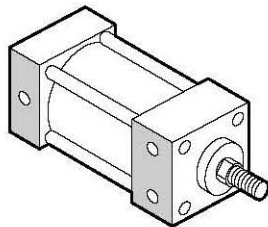

Code FS Head Rectangular Flange Mounts (ANSI MF1)

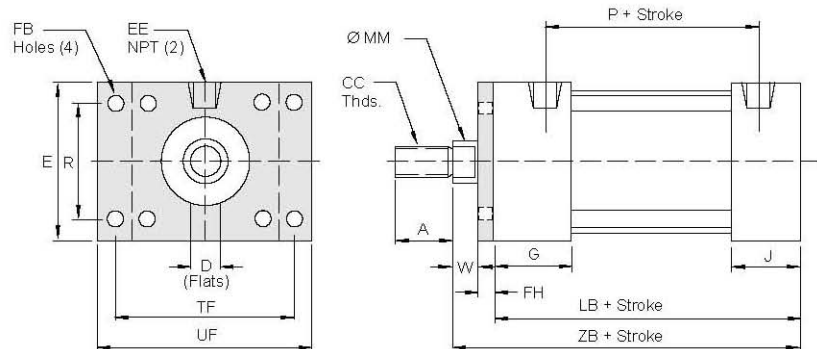
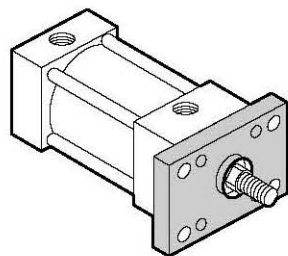

Series Q6/NQ 3/4 & 1-1/8 inch Bore Cylinders and Mounts

DIMENSION		EE BOLT THRU MOUNTS (MS8)		BSTAPPED (MS9)		FS HEAD RECT. FLANGE MOUNTS (MF1)	
		3/4"	1-1/8"	3/4"	1-1/8"	3/4"	1-1/8"
Rod	Std.	.312 (7.92)	.375 (9.53)	.312 (7.92)	.375 (9.53)	.312 (7.92)	.375 (9.53)
	O.S.	-	.500 (12.70)	-	.500 (12.70)	-	.500 (12.70)
A	Std.	.625 (15.88)	.625 (15.88)	.625 (15.88)	.625 (15.88)	.625 (15.88)	.625 (15.88)
	O.S.	-	.750 (19.05)	-	.750 (19.05)	-	.750 (19.05)
C		.250 (6.35)	.250 (6.35)	.250 (6.35)	.250 (6.35)	.250 (6.35)	.250 (6.35)
CC	Std.	1/4 - 28	3/8 - 24	1/4 - 28	3/8 - 24	1/4 - 28	3/8 - 24
	O.S.	-	1/2 - 20	-	1/2 - 20	-	1/2 - 20
D	Std.	.250 (6.35)	.312 (7.92)	.250 (6.35)	.312 (7.92)	.250 (6.35)	.312 (7.92)
	O.S.	-	.437 (11.10)	-	.437 (11.10)	-	.437 (11.10)
DB		.172 (4.37)	.203 (5.16)	-	-	-	-
DN		.625 (15.88)	1.000 (25.40)	-	-	-	-
E		1.000 (25.40)	1.500 (38.10)	1.000 (25.40)	1.500 (38.10)	-	-
EE		.125 (3.18)	.125 (3.18)	.125 (3.18)	.125 (3.18)	-	-
FB		-	-	-	-	.219 (5.56)	.219 (5.56)
FH		-	-	-	-	.250 (6.35)	.250 (6.35)
G		.875 (22.23)	.875 (22.23)	.875 (22.23)	.875 (22.23)	.875 (22.23)	.875 (22.23)
H		.687 (17.45)	.625 (15.88)	-	-	-	-
J		.625 (15.88)	.625 (15.88)	.625 (15.88)	.625 (15.88)	.625 (15.88)	.625 (15.88)
K		.375 (9.53)	.375 (9.53)	-	-	-	-
LB		2.250 (57.15)	2.250 (57.15)	2.250 (57.15)	2.250 (57.15)	2.250 (57.15)	2.250 (57.15)
MM	Std.	.307 (7.80)	.307 (7.80)	.307 (7.80)	.307 (7.80)	.307 (7.80)	.307 (7.80)
	O.S.	-	.495 (12.57)	-	.495 (12.57)	-	.495 (12.57)
NT		-	-	8 - 32	10 - 32	-	-
P		-	-	1.375 (34.93)	1.375 (34.93)	1.375 (34.93)	1.375 (34.93)
R		-	-	-	-	.500 (12.70)	1.000 (25.40)
RM	Std.	.562 (14.27)	.750 (19.05)	.562 (14.27)	.750 (19.05)	-	-
	O.S.	-	1.000 (25.40)	-	1.000 (25.40)	-	-
SB		#8	#10	-	-	-	-
SN		-	-	1.812 (46.02)	1.750 (44.45)	-	-
TB		.281 (7.14)	.328 (8.33)	-	-	-	-
TF		-	-	-	-	1.500 (38.10)	2.000 (56.80)
TK		-	-	.187 (4.87)	.250 (6.35)	-	-
TN		-	-	.625 (15.88)	1.000 (25.40)	-	-
UF		-	-	-	-	2.000 (56.80)	2.500 (63.50)
V		.125 (3.18)	.125 (3.18)	.125 (3.18)	.125 (3.18)	.125 (3.18)	.125 (3.18)
XT		-	-	.562 (14.27)	.625 (15.88)	-	-
W		-	-	-	-	.125 (3.18)	.125 (3.18)
XB		.562 (14.27)	.625 (15.88)	-	-	-	-
Y		-	-	.938 (23.83)	.938 (23.83)	.938 (23.83)	.938 (23.83)
ZB		-	-	2.625 (66.68)	2.625 (66.68)	2.625 (66.68)	2.625 (66.68)

All dimensions in inches (mm)

Series Q6/NQ 3/4 & 1-1/8 inch Bore Cylinders and Mounts

Code RS Cap Rectangular Flange Mounts (ANSI MF2)

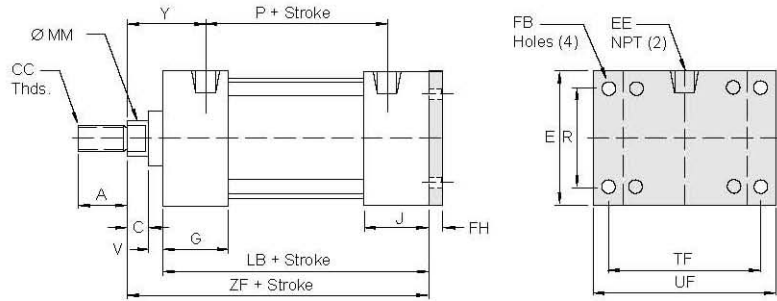
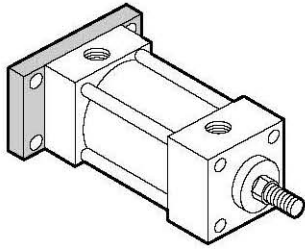

Code FM Head Tapped Face Mounts (ANSI MR1)

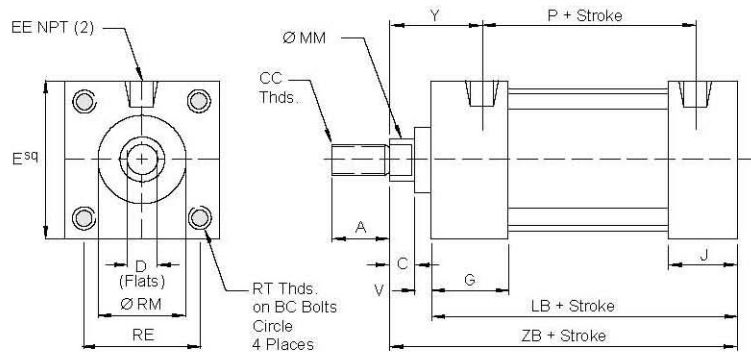
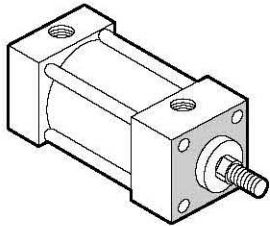

Code TN Threaded Nose Mounts (ANSI MNR1)

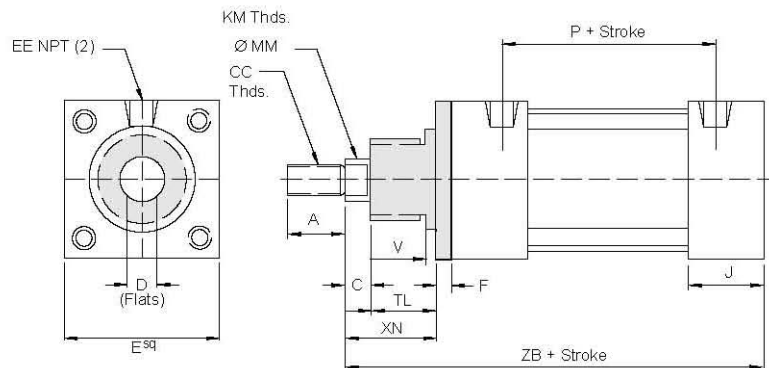
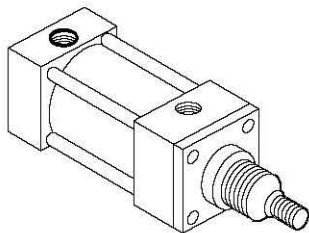

Series Q6/NQ 3/4 & 1-1/8 inch Bore Cylinders and Mounts

DIMENSION		RS CAP. RECT. FLANGE MOUNTS (MF2)		FM HEAD TAPPED FACE MOUNTS (MR1)		TN THREADED NOSE MOUNTS (MNR1)	
		3/4"	1-1/8"	3/4"	1-1/8"	3/4"	1-1/8"
Rod	Std.	.312 (7.92)	.375 (9.53)	.312 (7.92)	.375 (9.53)	.312 (7.92)	.375 (9.53)
	O.S.	-	.500 (12.70)	-	.500 (12.70)	-	.500 (12.70)
A	Std.	.625 (15.88)	.625 (15.88)	.625 (15.88)	.625 (15.88)	.625 (15.88)	.625 (15.88)
	O.S.	-	.750 (19.05)	-	.750 (19.05)	-	.750 (19.05)
C		.250 (6.35)	.250 (6.35)	.250 (6.35)	.250 (6.35)	.250 (6.35)	.250 (6.35)
CC	Std.	1/4 - 28	3/8 - 24	1/4 - 28	3/8 - 24	1/4 - 28	3/8 - 24
	O.S.	-	1/2 - 20	-	1/2 - 20	-	1/2 - 20
D	Std.	-	-	.250 (6.35)	.312 (7.92)	.250 (6.35)	.312 (7.92)
	O.S.	-	-	-	.437 (11.10)	-	.437 (11.10)
E		1.000 (25.40)	1.500 (38.10)	1.000 (25.40)	1.500 (38.10)	1.000 (25.40)	1.500 (38.10)
EE		.125 (3.18)	.125 (3.18)	.125 (3.18)	.125 (3.18)	.125 (3.18)	.125 (3.18)
F		-	-	-	-	.250 (6.35)	.250 (6.35)
FB		.219 (5.56)	.219 (5.56)	-	-	-	-
FH		.250 (6.35)	.250 (6.35)	-	-	-	-
G		.875 (22.23)	.875 (22.23)	.875 (22.23)	.875 (22.23)	.875 (22.23)	.875 (22.23)
J		.625 (15.88)	.625 (15.88)	.625 (15.88)	.625 (15.88)	.625 (15.88)	.625 (15.88)
KM		-	-	-	-	5/8 - 18	1 - 14
LB		2.250 (57.15)	2.250 (57.15)	2.250 (57.15)	2.250 (57.15)	2.250 (57.15)	2.250 (57.15)
MM	Std.	.307 (7.80)	.370 (9.40)	.307 (7.80)	.370 (9.40)	.307 (7.80)	.370 (9.40)
	O.S.	-	.495 (12.57)	-	.495 (12.57)	-	.495 (12.57)
P		1.375 (34.93)	1.375 (34.93)	1.375 (34.93)	1.375 (34.93)	1.375 (34.93)	1.375 (34.93)
R		.500 (12.70)	1.000 (25.40)	-	-	-	-
RE		.750 (19.05)	1.125 (28.58)	.750 (19.05)	1.125 (28.58)	-	-
RM	Std.	-	-	.625 (15.88)	.750 (19.05)	.625 (15.88)	1.062 (26.97)
	O.S.	-	-	-	-	-	-
RT		-	-	8 - 32	10 - 32	-	-
TF		1.500 (38.10)	2.000 (50.80)	-	-	-	-
TL		-	-	-	-	.625 (15.88)	.875 (22.23)
UF		2.000 (50.80)	2.500 (63.50)	-	-	-	-
V		.125 (3.18)	.125 (3.18)	.125 (3.18)	.125 (3.18)	.125 (3.18)	.125 (3.18)
XN		-	-	-	-	.875 (22.23)	1.125 (28.58)
Y		.938 (23.83)	.938 (23.83)	.938 (23.83)	.938 (23.83)	.938 (23.83)	.938 (23.83)
ZB		-	-	2.625 (66.68)	2.625 (66.68)	3.375 (85.73)	3.625 (92.08)
ZF		2.875 (73.03)	2.875 (73.03)	-	-	-	-

All dimensions in inches (mm)

Series Q6/NQ 3/4 & 1-1/8 inch Bore Cylinders and Mounts

Code KS No Mounts

(ANSI MX0)

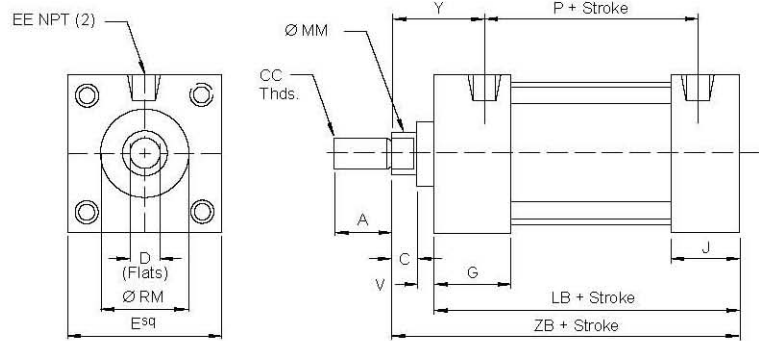
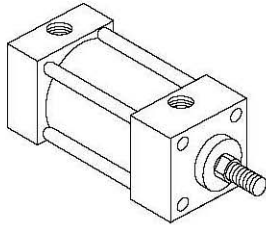

Code ED Double Rod, Bolt Thru Mounts

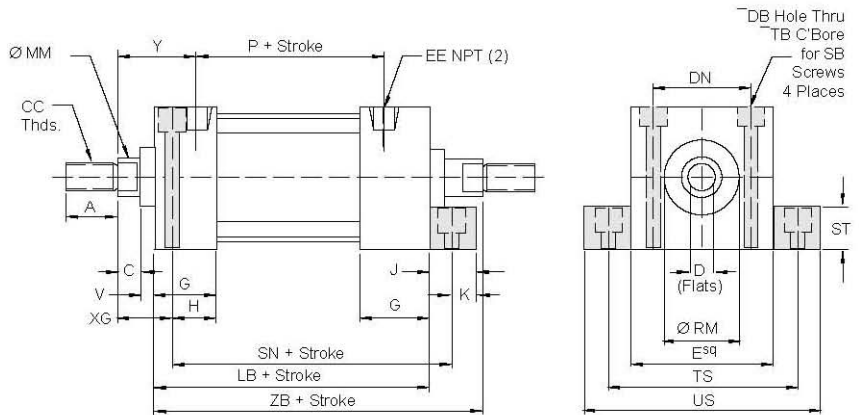
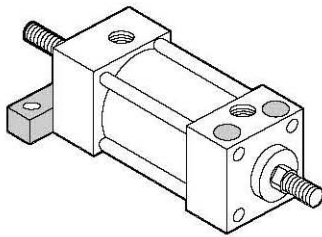

Code CM Fixed Eye Mounts

(ANSI MP3)

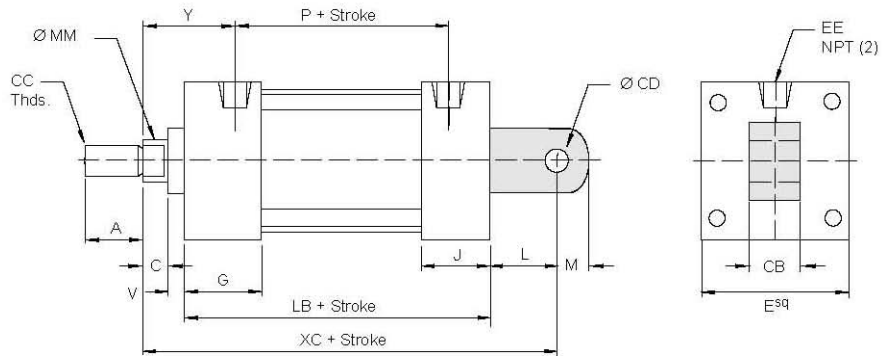
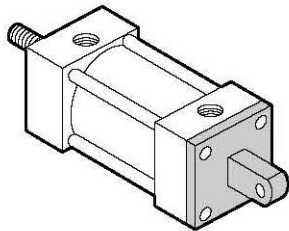

Series Q6/NQ 3/4 & 1-1/8 inch Bore Cylinders and Mounts

DIMENSION		KS NO MOUNT (MX0)		ED DOUBLE ROD BOLT THRU MOUNTS (MS8)		CM FIXED EYE MOUNTS (MP3)	
		3/4"	1-1/8"	3/4"	1-1/8"	3/4"	1-1/8"
Rod	Std.	.312 (7.92)	.375 (9.53)	.312 (7.92)	.375 (9.53)	.312 (7.92)	.375 (9.53)
	O.S.	-	.500 (12.70)	-	.500 (12.70)	-	.500 (12.70)
A	Std.	.625 (15.88)	.625 (15.88)	.625 (15.88)	.625 (15.88)	.625 (15.88)	.625 (15.88)
	O.S.	-	.750 (19.05)	-	.750 (19.05)	-	.750 (19.05)
C		.250 (6.35)	.250 (6.35)	.250 (6.35)	.250 (6.35)	.250 (6.35)	.250 (6.35)
CB		-	-	-	-	.250 (6.35)	.375 (9.53)
CC	Std.	1/4 - 28	3/8 - 24	1/4 - 28	3/8 - 24	1/4 - 28	3/8 - 24
	O.S.	-	1/2 - 20	-	1/2 - 20	-	1/2 - 20
CD		-	-	-	-	.250 (6.35)	.375 (9.53)
D	Std.	.250 (6.35)	.312 (7.92)	.250 (6.35)	.312 (7.92)	.250 (6.35)	-
	O.S.	-	.437 (11.10)	-	.437 (11.10)	-	-
DB		-	-	.172 (4.37)	.203 (5.16)	-	-
DN		-	-	.625 (15.88)	1.000 (25.40)	-	-
E		1.000 (25.40)	1.500 (38.10)	1.000 (25.40)	1.500 (38.10)	1.000 (25.40)	1.500 (38.10)
EE		.125 (3.18)	.125 (3.18)	.125 (3.18)	.125 (3.18)	.125 (3.18)	.125 (3.18)
G		.875 (22.23)	.875 (22.23)	.875 (22.23)	.875 (22.23)	.875 (22.23)	.875 (22.23)
H		-	-	.687 (17.45)	.625 (15.88)	-	-
J		.625 (15.88)	.625 (15.88)	.500 (12.70)	.500 (12.70)	.625 (15.88)	.625 (15.88)
K		-	-	.250 (6.35)	.250 (6.35)	-	-
L		-	-	-	-	.437 (11.10)	.437 (11.10)
LB		2.250 (57.15)	2.250 (57.15)	2.250 (57.15)	2.250 (57.15)	2.250 (57.15)	2.250 (57.15)
M		-	-	-	-	.250 (6.53)	.375 (9.53)
MM	Std.	.307 (7.80)	.370 (9.40)	.307 (7.80)	.370 (9.40)	.307 (7.80)	.370 (9.40)
	O.S.	-	.495 (12.57)	-	.495 (12.57)	-	.495 (12.57)
P		1.375 (34.93)	1.375 (34.93)	1.375 (34.93)	1.375 (34.93)	1.375 (34.93)	1.375 (34.93)
RM	Std.	.562 (14.27)	.750 (19.05)	.625 (15.88)	.750 (19.05)	-	-
	O.S.	-	1.000 (25.40)	-	1.000 (25.40)	-	-
SB		-	-	#8	#10	-	-
SD		-	-	2.562 (65.07)	2.500 (63.50)	-	-
ST		-	-	.375 (9.53)	.375 (9.53)	-	-
TB		-	-	.281 (7.14)	.328 (8.33)	-	-
TS		-	-	1.375 (34.93)	1.875 (47.63)	-	-
US		-	-	1.750 (44.45)	2.250 (57.15)	-	-
V		.125 (3.18)	.125 (3.18)	.125 (3.18)	.125 (3.18)	.125 (3.18)	.125 (3.18)
XC		-	-	-	-	3.062 (77.77))	3.062 (77.77))
XG		-	-	.562 (14.27)	.625 (15.88)	-	-
Y		.938 (23.83)	.938 (23.83)	.938 (23.83)	.938 (23.83)	.938 (23.83)	.938 (23.83)
ZB		2.625 (66.68)	2.625 (66.68)	3.250 (82.55)	3.250 (82.55)	-	-

All dimensions in inches (mm)

Series Q6/NQ 3/4 & 1-1/8 inch Bore Cylinders and Mounts

Code DE Detachable Eye Mounts (ANSI MP4)

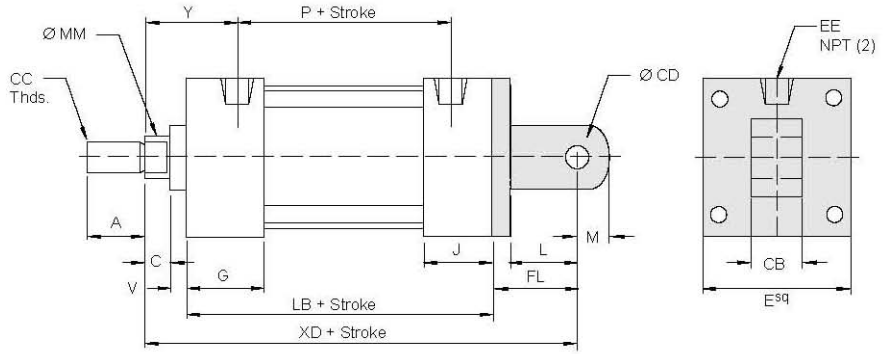
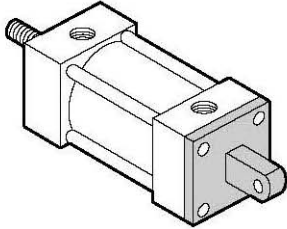

Code DC Detachable Clevis Mounts (ANSI MP2)

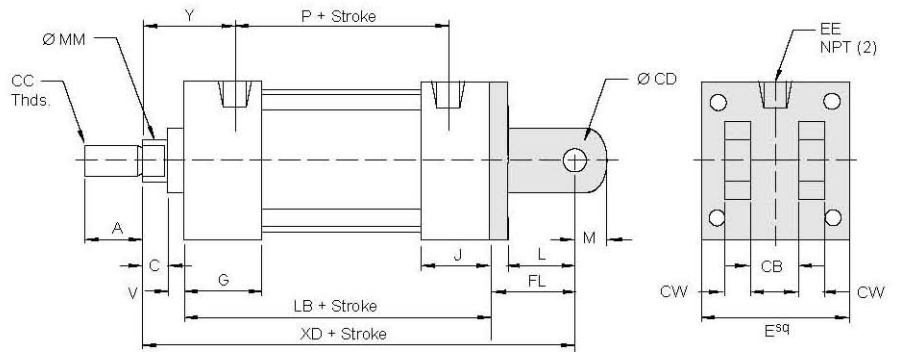
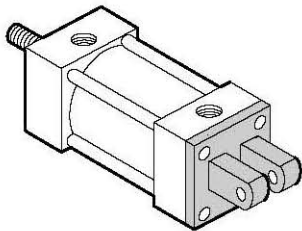

Series Q6/NQ
3/4 & 1-1/8 inch
Bore Cylinders
and Mounts

DIMENSION		DE DETACHABLE EYE MOUNTS (MP4)		DC DETACHABLE CLEVIS MOUNTS (MP2)	
		3/4"	1-1/8"	3/4"	1-1/8"
Rod	Std.	.312 (7.92)	.375 (9.53)	.312 (7.92)	.375 (9.53)
	O.S.	-	.500 (12.70)	-	.500 (12.70)
A	Std.	.625 (15.88)	.625 (15.88)	.625 (15.88)	.625 (15.88)
	O.S.	-	.750 (19.05)	-	.750 (19.05)
C		.250 (6.35)	.250 (6.35)	.250 (6.35)	.250 (6.35)
CB		.250 (6.35)	.375 (9.53)	.250 (6.35)	.375 (9.53)
CC	Std.	1/4 - 28	3/8 - 24	1/4 - 28	3/8 - 24
	O.S.	-	1/2 - 20	-	1/2 - 20
CD		.250 (6.35)	.375 (9.53)	.250 (6.35)	.375 (9.53)
D	Std.	.250 (6.35)	.312 (7.92)	-	-
	O.S.	-	.437 (11.10)	-	-
E		1.000 (25.40)	1.500 (38.10)	1.000 (25.40)	1.500 (38.10)
EE		.125 (3.18)	.125 (3.18)	.125 (3.18)	.125 (3.18)
FL		.937 (23.80)	1.125 (28.58)	1.125 (28.58)	1.125 (28.58)
G		.875 (22.23)	.875 (22.23)	.875 (22.23)	.875 (22.23)
J		.625 (15.88)	.625 (15.88)	.625 (15.88)	.625 (15.88)
L		.437 (11.10)	.625 (15.88)	.625 (15.88)	.625 (15.88)
LB		2.250 (57.15)	2.250 (57.15)	2.250 (57.15)	2.250 (57.15)
M		.250 (6.35)	.375 (9.53)	.250 (6.35)	.375 (9.53)
MM	Std.	.307 (7.80)	.370 (9.40)	.307 (7.80)	.370 (9.40)
	O.S.	-	.495 (12.57)	-	.495 (12.57)
P		1.375 (34.93)	1.375 (34.93)	1.375 (34.93)	1.375 (34.93)
V		.125 (3.18)	.125 (3.18)	.125 (3.18)	.125 (3.18)
XD		3.562 (90.47)	3.750 (95.25)	3.750 (95.25)	3.750 (95.25)
Y		.938 (23.83)	.938 (23.83)	.938 (23.83)	.938 (23.83)

All dimensions in inches (mm)

Series Q6/NQ Rod Ends for 3/4 & 1-1/8 inch Bore Cylinders

Rod End Types

In addition to selecting the correct bore, you must specify the appropriate rod size and rod end configuration for your application.

Three different inch rod end configurations are available. If a custom design is required, contact your local Eaton sales engineer, and define your requirements.

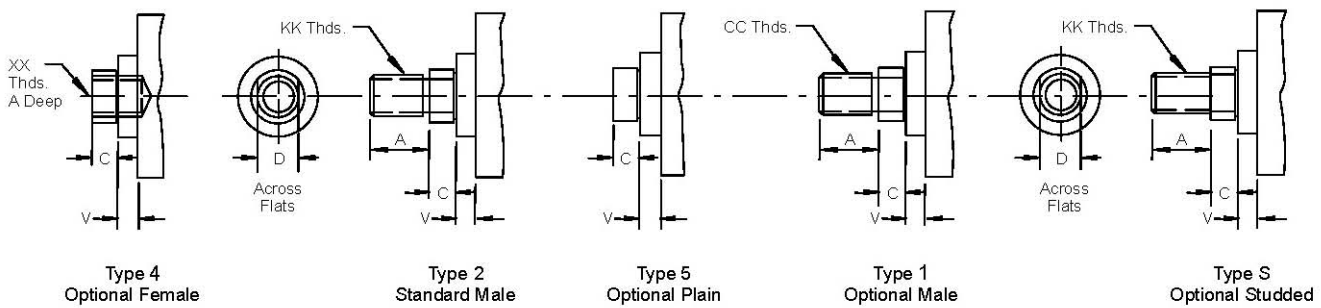

DIMENSION		STANDARD & OPTIONAL ROD ENDS	
		3/4"	1-1/8"
Rod	Std.	.312 (7.92)	.375 (9.53)
	O.S.	-	.500 (12.70)
A	Std.	.625 (15.88)	.625 (15.88)
	O.S.	-	.750 (19.05)
C		.250 (6.35)	.250 (6.35)
CC	Std.	5/16 - 24	3/8 - 24
	O.S.	-	1/2 - 20
D	Std.	.250 (6.35)	.312 (7.92)
	O.S.	-	.437 (11.10)
KK	Std.	1/4 - 28	5/16 - 24
	O.S.	-	7/16 - 20
V		.125 (3.18)	.125 (3.18)
XX	Std.	10 - 32	1/4 - 28
	O.S.	-	3/8 - 24

All dimensions in inches (mm)

Series Q6/NQ Accessories for 3/4 & 1-1/8 inch Bore Cylinders

Rod Clevis

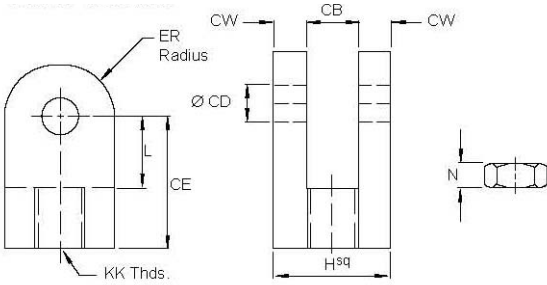

	3/4 Q662004A*	Q662004B*	1-1/8 Q662006A*	Q662006B*
CB	.250 (6.35)	.250 (6.35)	.375 (9.53)	.375 (9.53)
CD	.250 (6.35)	.250 (6.35)	.375 (9.53)	.375 (9.53)
CE	.812 (20.60)	.812 (20.60)	.875 (22.23)	.875 (22.23)
CW	.125 (3.18)	.125 (3.18)	.187 (4.75)	.187 (4.75)
ER	.250 (6.35)	.250 (6.35)	.375 (9.53)	.375 (9.53)
H	.500 (12.70)	.500 (12.70)	.750 (19.05)	.750 (19.05)
KK	1/4 - 28	5/16 - 24	3/8 - 24	1/2 - 20
L	.500 (12.70)	.500 (12.70)	.500 (12.70)	.500 (12.70)
N	.156 (3.96)	.187 (4.75)	.219 (5.56)	.312 (7.92)

*Includes Jam Nut

Rod Eye

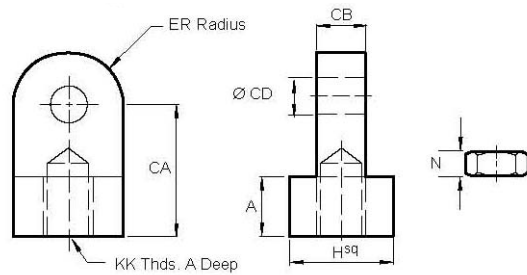

	3/4 Q660004A*	Q660004B*	1-1/8 Q660006A*	Q660006B*
A	.312 (7.92)	.312 (7.92)	.437 (11.10)	.437 (11.10)
CA	.750 (19.05)	.750 (19.05)	.875 (22.23)	.875 (22.23)
CB	.250 (6.35)	.250 (6.35)	.375 (9.53)	.375 (9.53)
CD	.250 (6.35)	.250 (6.35)	.375 (9.53)	.375 (9.53)
ER	.250 (6.35)	.250 (6.35)	.375 (9.53)	.375 (9.53)
H	.500 (12.70)	.500 (12.70)	.750 (19.05)	.750 (19.05)
KK	1/4 - 28	5/16 - 24	3/8 - 24	1/2 - 20
N	.156 (3.96)	.187 (4.75)	.219 (5.56)	.312 (7.92)

*Includes Jam Nut

Clevis Bracket

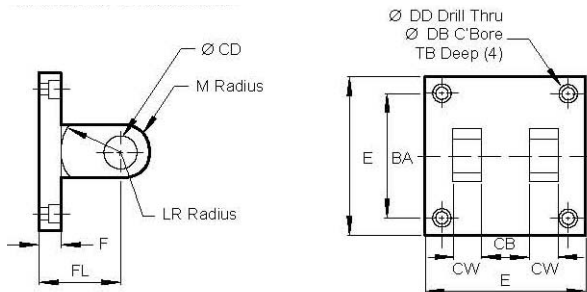

	3/4 Q661004A	1-1/8 Q661006A
BA	.750 (19.05)	1.125 (28.58)
CB	.250 (6.35)	.375 (9.53)
CD	.250 (6.35)	.375 (9.53)
CW	.250 (6.35)	.250 (6.35)
DB	.250 (6.35)	.328 (8.33)
DD	.156 (3.96)	.203 (5.16)
E	1.000 (25.40)	1.500 (38.10)
F	.500 (12.70)	.500 (12.70)
FL	1.125 (28.58)	1.125 (28.58)
LR	.437 (11.10)	.625 (15.88)
M	.250 (6.35)	.375 (9.53)
TB	.125 (3.18)	.250 (6.53)

All dimensions in inches (mm)

Series Q6/NQ Accessories for 3/4 & 1-1/8 inch Bore Cylinders

Eye Bracket

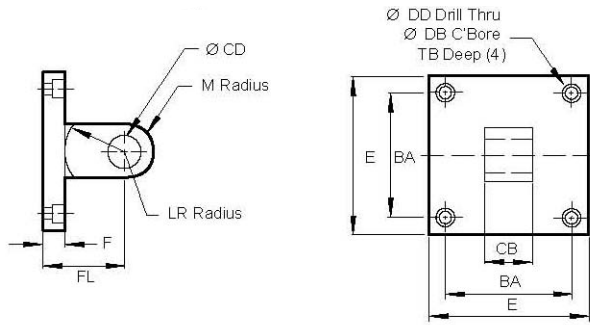

	3/4 Q678004A	1-1/8 Q678006A
BA	.750 (19.05)	1.125 (28.58)
CB	.250 (6.35)	.375 (9.53)
CD	.250 (6.35)	.375 (9.53)
DB	.250 (6.35)	.328 (8.33)
DD	.156 (3.96)	.203 (5.16)
E	1.000 (25.40)	1.500 (38.10)
F	.500 (12.70)	.500 (12.70)
FL	.937 (23.80)	1.125 (28.58)
LR	.437 (11.10)	.625 (15.88)
M	.250 (6.35)	.375 (9.53)
TB	.125 (3.18)	.250 (6.53)

Clevis Pin

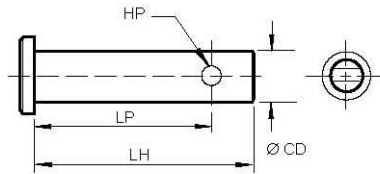

	3/4 Q683004B	Q683004C	1-1/8 Q683006B	Q683006C
CD	.250 (6.35)	.250 (6.35)	.375 (9.53)	.375 (9.53)
HP	.094 (2.39)	.094 (2.39)	.156 (3.96)	.156 (3.96)
LH	.750 (19.05)	1.000 (25.40)	1.094 (27.79)	1.250 (31.75)
LP	.656 (16.66)	.906 (23.01)	.937 (23.80)	1.032 (26.21)
Use	Q662004A	Q678004A	Q662006A	Q678006A
w/	Q6620048	Q661004A	Q662006B	Q661006A
-		Q660004A	-	Q660006A

All dimensions in inches (mm)

Series Q6/NQ Switches for 3/4 thru 8 inch Bore Cylinders

Eaton utilizes a magnetically operated, non-contact sensing system consisting of a magnet in the piston, and a sensing switch clamped to the cylinder tie rod.

One or more switches may be mounted to provide an indication of piston position.

Switches use vinyl molded cable, and are supplied with

adjustable mounting brackets allowing the switches to be securely positioned anywhere along the range of piston travel.

LED indicator lights facilitate installation and troubleshooting.

Reed Switch Working Principle

Reed switch sensors contain hermetically sealed reed elements (mechanical contacts) which are open in their normal state. When a magnetic field moves within proximity of the switch, magnetism is induced into the leads and forces the contacts to close.

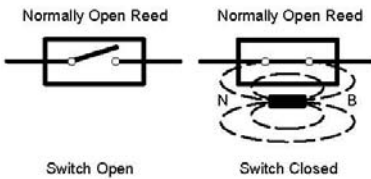

Application Recommendations and Precautions

To provide maximum reliability:

1. Always stay within the specifications and power rating limitations of the unit installed.
2. Primary and control circuit wiring should not be mixed in the same conduit.

Motors will produce high pulses that will be introduced into the control wiring if the wiring is carried in the same conduit.

3. Never connect the switch without a load present. The switch will be destroyed.
4. Some electrical loads may be capacitive. Capacitive loading may occur due to distributed capacity in cable runs over 25 feet. Use switch Model PS7-24 whenever capacitive loading may occur.

Hall Effect/Magnetostrictive Working Principle

The solid state (no moving parts) magnetostrictive sensor responds to a parallel magnetic pole by providing a digital signal to the output control circuit. This technique enables the sensing of weak magnetic fields, with no limit to the maximum strength of the magnetic field.

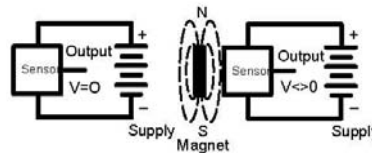

In order to obtain optimum performance and long life, magnetically operated limit switches should not be subjected to:

- (1) strong magnetic fields,
- (2) extreme temperature, and
- (3) excessive ferrous filing or chip buildup.

Improper wiring may damage or destroy the switch. The wiring diagram, along with the listed power ratings, must be carefully observed before connecting power to the switch.

Lower power switches are designed for signaling electronic circuits. Do not use on relay loads or with incandescent bulbs. Resistive loads only.

Switch and Mounting Bracket Dimensions

PS8-2 Series

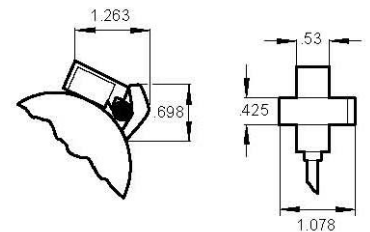

Series Q6/NQ Specifications: 3/4 thru 2-1/2 inch Bores

Metal Oxide Varsistor surge Suppression. Note: All PS7 and PS Series Switches are supplied with 9 foot leads.

Switch Model	PS8-2-04 Reed	PS8-2-31 Hall	PS8-2-32 Hall
Bore Sizes	3/4 thru 2-1/2	3/4 thru 2-1/2	3/4 thru 2-1/2
Switch Type	Reed Switch *MOV & Light	Hall Effect & Light, Sourcing PNP	Hall Effect & Light, Sinking PNP
Function	SPST Normally Open	Normally Open	Normally Open
Switching Voltage	5-120 VDC/VAC 50/60 Hz	6-24 VDC	6-24 VDC
Switching Current	.5 Amp Max .005 Amp Min	.5 Amp Max	.5 Amp Max
Switching Power	10 VA	12 Watts Max	12 Watts Max
Max Voltage Drop	3.5 Volts	.5 Volts	.5 Volts
Magnetic Sensitivity	85 Gauss	85 Gauss	85 Gauss
Enclosure Classification	NEMA 6 & CSA Approved	NEMA 6 & CSA Approved	NEMA 6 & CSA Approved
Temperature Range	-22_F to +176_F	-22_F to +176_F	-22_F to +176_F

Wiring Diagrams

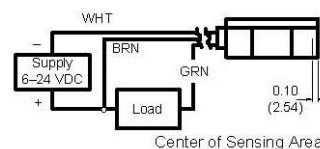
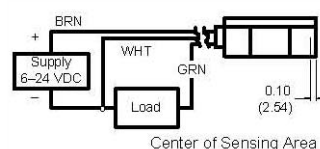
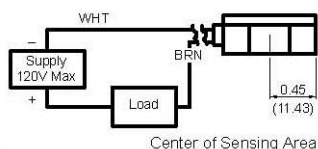

Specifications: 2 thru 8 inch Bores

PS7-04 Reed	PS7-24 Reed	PS7-31 Hall	PS7-32 Hall
2 1/2 thru 8 1/2	2 1/2 thru 8 1/2	2 1/2 thru 8 1/2	2 1/2 thru 8 1/2
Reed Switch *MOV & Light	Reed Switch *MOV & Light, 3 Wire	Hall Effect & Light, Sourcing PNP	Hall Effect & Light, Sinking PNP
Normally Open	Normally Open	Normally Open	Normally Open
5-240 VDC/VAC 50/60 Hz	24-240 VAC 50/60 Hz	6-24 VAC	6-24 VAC
1 Amp Max	4 Amp Max 50 Amp Inrush	1 Amp Max	1 Amp Max
30 Watts Max	100 Watts Max	24 Watts Max	24 Watts Max
3 Volts	N/A	.5 Volts	.5 Volts
85 Gauss	85 Gauss	85 Gauss	85 Gauss
Parallel	Parallel	Parallel	Parallel
NEMA 6 & CSA Approved	NEMA 6 & CSA Approved	NEMA 6 & CSA Approved	NEMA 6 & CSA Approved
-22_F to +176_F	-22_F to +176_F	-22_F to +176_F	-22_F to +176_F

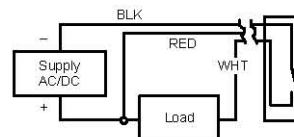
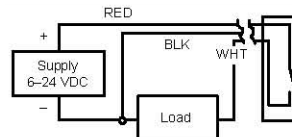
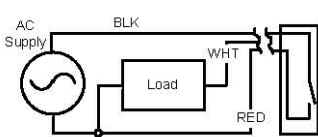
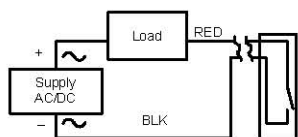

Note: For 8 1/2 inch bore add 9 to part number. Example: PS7-9-04

PS7 Series

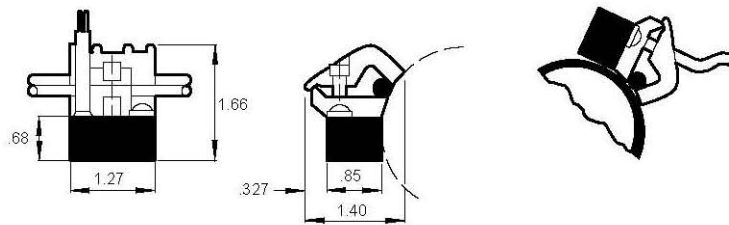
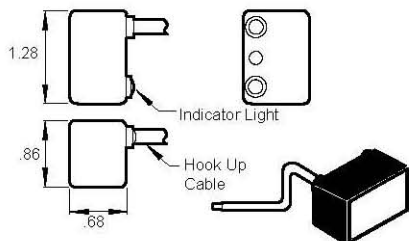

Series Q6/NQ Technical Information

Operating Temperatures:

A Seal Code -40_F to 200_F
(-40_C to 93_C)
T Seal Code -20_F to 400_F
(-29_C to 204_C)

Operating Pressure:

250 psig air (17.2 bar)
400 psig hydraulic (27.6 bar)
Bore Sizes: 3/4", 1-1/8",
1-1/2", 2", 2-1/2", 3-1/4", 4",
5", 6", 8"

Note: 3/4" and 1-1/8" bores
are not rated for hydraulic
service.

Supply:

Filtered compressed air to
250 psi Petroleum based
hydraulic fluid to 400 psi

Lubrication:

None required
Eaton's Hydro-Line®
Pneumatic Cylinders are
rated for "no lube added"
service. All internal
components are lubricated
at time of assembly with a
Teflon® based grease.

Series Q6 Materials:

Head and End Caps:
anodized aluminum
Body: aluminum, clear
anodized O.D., hard coat
anodized I.D.
Rod: hard chrome plated steel
Piston: solid aluminum alloy
Rod Bearing: cast iron,
Teflon® coated
Seals: urethane rod seal and
wiper, nitrile piston seals
Tie Rods: steel

Alternate Series NQ Materials:

Body: stainless steel
Rod: stainless steel
Rod Bearing: stainless steel
Tie Rods: stainless steel

Side Loading:

Cylinders are specifically
designed to push and pull.
Side loading of the piston
rod should be avoided to
ensure maximum operating
performance and life.
Care should be taken during
installation to properly align
the load to be moved with
the center line of the cylinder.
The use of a rod alignment
coupler (see page 45) is
strongly recommended
whenever possible.

Series Q6/NQ Technical Information

Cylinder Weights

In pounds (kilograms)

		MOUNTING CODE							
BORE INCH	(MM)	ROD INCH	(MM)	BS, KS, FM	FS	RS, PP	LS		
1 1/2"	(38.10)	5/8"	(15.88)	1.9 (.86)	2.6 (1.18)	2.7 (.23)	2.1 (.95)		
2"	(50.80)	5/8"	(15.88)	2.8 (1.27)	3.9 (.77)	4.0 (1.81)	3.1 (1.41)		
		1"	(25.40)	3.4 (1.54)	4.4 (2.00)	4.6 (2.09)	3.7 (1.68)		
2 1/2"	(63.50)	5/8"	(15.88)	3.9 (.77)	5.3 (2.40)	5.5 (2.49)	4.1 (1.86)		
		1"	(25.40)	4.5 (2.04)	5.9 (2.68)	6.1 (2.77)	4.7 (2.13)		
3 1/4"	(82.55)	1"	(25.40)	7.3 (3.31)	10.8 (4.90)	11.1 (5.03)	7.7 (3.49)		
		1 3/8"	(34.93)	8.2 (3.72)	11.5 (5.22)	12.1 (5.49)	8.7 (3.95)		
4"	(101.60)	1"	(25.40)	9.8 (4.45)	14.8 (6.71)	15.1 (6.85)	10.2 (4.63)		
		1 3/8"	(34.93)	10.8 (4.90)	15.5 (7.03)	16.1 (7.30)	11.2 (5.08)		
5"	(127.00)	1"	(25.40)	15.1 (6.85)	22.7 (10.30)	23.1 (10.48)	16.1 (7.30)		
		1 3/8"	(34.93)	16.2 (7.35)	23.5 (10.66)	24.1 (10.93)	17.2 (7.80)		
6"	(152.40)	1 3/8"	(34.93)	23.5 (16.19)	35.6 (16.15)	36.3 (16.47)	24.5 (11.11)		
		1 3/4"	(44.45)	24.8 (11.27)	36.9 (16.77)	37.6 (17.09)	25.8 (11.73)		
7"	(177.80)	1 3/8"	(34.93)	32.1 (14.56)	32.1 (14.56)	32.1 (14.56)	33.4 (15.15)		
		1 3/4"	(44.45)	33.4 (15.18)	33.4 (15.18)	33.4 (15.18)	34.7 (15.77)		
8"	(203.20)	1 3/8"	(34.93)	40.0 (18.14)	40.0 (18.14)	40.0 (18.14)	41.3 (18.73)		
		1 3/4"	(44.45)	47.3 (21.50)	41.3 (18.77)	41.3 (18.77)	42.6 (19.36)		

All dimensions in inches (mm). All weights in pounds (kilograms).

Listed are the average breakaway pressures in psi for all Series Q6/NQ Cylinders.

If your application requires a lower breakaway pressure than indicated for a particular bore size, consult the factory.

Breakaway Pressures in PSI (bar)

BORE	A SEALS		T SEALS	
	EXTEND	RETRACT	EXTEND	RETRACT
3/4"	9 (.62)	10 (.69)	5 (.35)	6 (.41)
1 1/8"	6 (.41)	7 (.48)	3 (.21)	4 (.28)
1 1/2", 2", 2 1/2"	6 (.41)	7 (.48)	3 (.21)	4 (.28)
3 1/4", 4"	4 (.28)	5 (.35)	2 (.14)	3 (.21)
5", 6", 8"	3 (.21)	4 (.28)	1 (.07)	2 (.14)

Note: Breakaway pressures were established with the cylinders mounted horizontally and no load on the piston rod.

Series Q6/NQ Technical Information

MOUNTING CODE

AS, WS, US		YY		CF		ES		GG, DC, CF, CM		DE		ADD PER INCH OF STROKE	
2.5	(1.13)	2.3	(1.04)	2.8	(1.27)	2.5	(1.13)	3.0	(1.36)	2.8	(1.27)	0.18	(.08)
3.5	(1.59)	3.3	(1.50)	4.0	(1.81)	3.8	(1.72)	4.2	(1.91)	3.9	(1.77)	0.21	(.10)
4.1	(1.86)	3.9	(1.77)	4.6	(2.09)	4.4	(2.00)	4.8	(2.18)	4.5	(2.04)	0.35	(.16)
4.6	(2.09)	4.4	(2.00)	5.3	(2.40)	5.3	(2.40)	5.5	(2.49)	5.3	(2.40)	0.23	(.10)
5.2	(2.36)	5.1	(2.31)	5.9	(2.68)	6.0	(2.72)	6.1	(2.77)	5.9	(2.68)	0.38	(.17)
8.9	(4.04)	8.2	(3.72)	11.1	(5.03)	9.7	(4.40)	11.8	(5.35)	11.4	(5.17)	0.42	(.19)
9.9	(4.50)	9.2	(4.17)	12.1	(5.49)	10.7	(4.85)	12.8	(5.80)	12.4	(5.62)	0.63	(.29)
11.5	(5.22)	10.9	(4.94)	14.8	(6.71)	13.3	(6.03)	15.5	(7.03)	15.2	(6.89)	0.45	(.20)
12.5	(5.67)	11.9	(5.40)	15.8	(7.17)	14.3	(6.49)	16.5	(7.48)	16.2	(7.35)	0.66	(.30)
18.7	(8.48)	17.6	(7.98)	22.2	(10.07)	20.8	(9.43)	22.8	(10.34)	22.5	(10.21)	0.51	(.23)
19.7	(8.94)	18.6	(8.44)	23.2	(10.52)	21.9	(9.93)	23.9	(10.84)	23.5	(10.70)	0.73	(.33)
27.3	(12.38)	26.6	(12.07)	35.7	(10.66)	32.1	(14.56)	37.0	(16.78)	36.3	(16.47)	0.77	(.35)
28.3	(12.86)	27.9	(12.68)	35.2	(15.97)	33.4	(15.18)	38.3	(17.41)	37.6	(17.09)	1.03	(.47)
33.5	(15.20)	36.8	(16.69)	36.5	(16.59)	32.1	(14.56)	48.9	(22.18)	48.2	(21.86)	1.00	(.45)
34.8	(15.82)	38.1	(17.32)	37.0	(16.82)	33.4	(15.18)	50.2	(22.82)	49.5	(22.50)	1.26	(.57)
41.4	(18.78)	45.7	(20.73)	43.0	(19.50)	40.0	(18.14)	60.5	(27.44)	59.7	(27.08)	1.06	(.48)
42.7	(19.41)	47.0	(21.36)	44.3	(20.14)	41.3	(18.77)	61.8	(28.09)	61.0	(27.73)	1.32	(.60)

All dimensions in inches (mm). All weights in pounds (kilograms).

Series Q6/NQ Technical Information

Piston Rod Diameter Selection:

Applications requiring long extend (push) strokes may require oversize piston rod diameters to prevent buckling. To determine the correct rod diameter for your application, follow these simple steps:

1. Select the force from the **Cylinder Force and Volume Chart** that is required for your application.

$$\text{Force} = \text{Piston Surface Area} \times \text{Operating Pressure}$$

2. From the **Cylinder Mounting Diagrams** select the mounting style being used.

3. With the piston rod fully extended, calculate the value of D (in inches) using the formula shown or the cylinder mounting diagram selected in step #2.
4. Locate the value of D (in inches) at the bottom of the **Selection Chart**. Enter the chart at this point and move vertically upward until intersecting with the horizontal line representing the required thrust which was selected in step #1. The band within which these lines intersect represents the minimum recommended piston rod diameter.

Stop Tube Selection:

Stop tubes enhance the transverse load carrying capability of a long stroke cylinder by increasing the distance between the piston and rod bearing at full extension. When the value of D (calculated from the piston rod diameter selection instructions above) is less than 40", a stop tube is not required. However, if D is 40" or more, 1" of stop tube is recommended for every 10" (or fraction thereof) over 40".

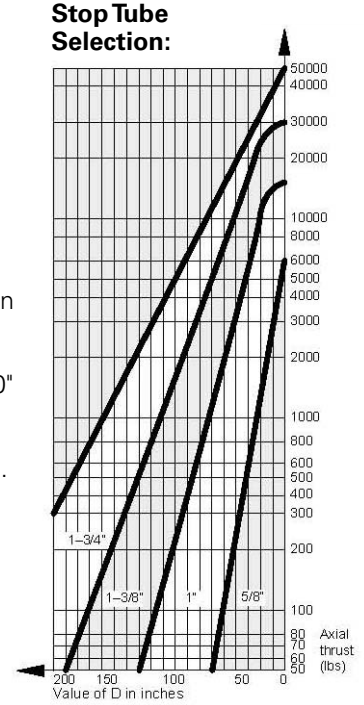

Cylinder Mounting Diagrams

Firmly Guided Rod End

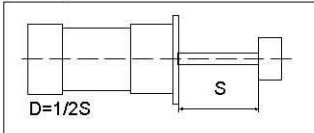

Head Trunnion

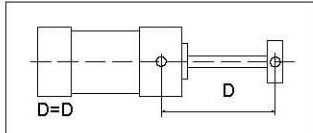

Unsupported Rod End

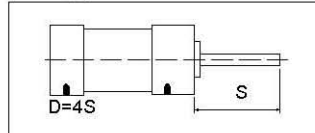

Supported Rod End

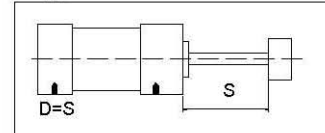

Firmly Guided Rod

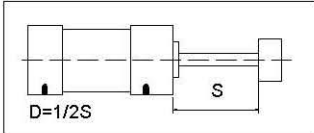

Cap Clevis or Cap Trunnion

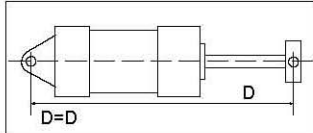

Unsupported Rod End

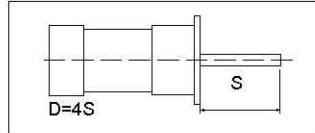

Supported Rod End

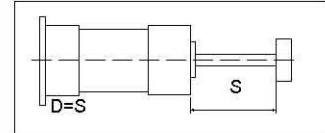

Series Q6/NQ Technical Information

Stop Tubes

As the stroke of a cylinder increases, the resultant loads on the piston rod become greater. To keep these bearing loads from exceeding design limitations and to obtain optimum life from a cylinder, stop tubes should be specified according to the following procedure:

Stop Tube Design

Three typical stop tube designs are illustrated below.

Design A

Used for cylinders non-cushioned on the rod.

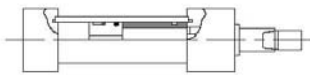

Stop Tube

SPECIFY ONE INCH OF STOP TUBE FOR EACH 10 INCHES (OR FRACTION THEREOF) OF STROKE IN EXCESS OF THE MAXIMUM LISTED IN THE FOLLOWING TABLE.

Maximum Stroke Permissible Without Stop Tube

BORE DIAMETER	PIVOT MOUNT CYLINDER (CLEVIS & TRUNNION)	RIGID MOUNT CYLINDER (WITHOUT ROD SUPPORT)	RIGID MOUNT CYLINDER (WITH ROD SUPPORT)
1-1/2" & 2"	24"	30"	48"
2-1/2" to 4"	30"	38"	48"
5" to 8"	36"	40"	48"

Design B

Used for cushioned hydraulic cylinders.

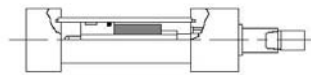

Stop Spacer

Design C

The best choice for a cylinder with an exceptionally long stop tube requirement. Note that the piston's effective bearing area is doubled. In addition to gaining the normal increased minimum distance between bearing points.

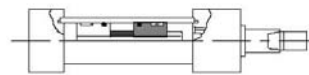

Double Piston with Spacer

Series Q6/NQ Technical Information

Cylinder Force and Volume Charts

Extend Forces in pounds (newtons)

BORE	PISTON AREA		PSI (BAR)								VOL. CU. FT. (CM ³) DISPLACEMENT PER STROKE INCH
	IN ² (CM ²)		40 (3)	60 (4)	80 (6)	100 (7)	150 (10)	200 (14)			
1-1/2"	1.77 (11.40)		71 (315)	106 (472)	142 (629)	177 (786)	266 (1179)	353 (1570)		.00102 (29)	
2"	3.14 (20.27)		126 (559)	189 (839)	251 (1119)	314 (1398)	471 (2097)	628 (2793)		.00182 (52)	
2-1/2"	4.91 (31.67)		196 (874)	295 (1311)	393 (1748)	491 (2185)	737 (3277)	982 (4368)		.00284 (80)	
3-1/4"	8.30 (53.32)		332 (1477)	498 (2215)	664 (2953)	830 (3692)	1245 (5538)	1659 (7379)		.00480 (136)	
4"	12.57 (81.07)		503 (2237)	754 (3355)	1005 (4473)	1257 (5592)	1886 (8388)	2513 (11178)		.00727 (206)	
5"	19.64 (126.71)		785 (3491)	1178 (5240)	1571 (6988)	1964 (8736)	2946 (13104)	3928 (17472)		.01137 (322)	
6"	28.27 (182.39)		1130 (5026)	1696 (7544)	2262 (10061)	2827 (12574)	4240 (18860)	5654 (25149)		.01837 (520)	
8"	50.26 (324.26)		2010 (8940)	3015 (13411)	4020 (17881)	5026 (22356)	7539 (33533)	10052 (44711)		.02227 (631)	

Deduct these Forces for Retract Strokes

BORE	PISTON AREA		PSI (BAR)								VOL. CU. FT. (CM ³) DISPLACEMENT PER STROKE INCH
	IN ² (CM ²)		40 (3)	60 (4)	80 (6)	100 (7)	150 (10)	200 (14)			
5/8"	.307 (1.98)		12 (53)	18 (80)	25 (111)	31 (138)	46 (205)	61 (271)		.00018 (5)	
1"	.785 (5.06)		31 (138)	47 (209)	63 (280)	70 (351)	118 (525)	157 (698)		.00045 (13)	
1-3/8"	1.485 (9.58)		59 (262)	89 (396)	119 (529)	118 (525)	222 (997)	297 (1321)		.00086 (24)	
1-3/4"	2.404 (15.51)		95 (423)	144 (641)	192 (854)	240 (1068)	360 (1601)	480 (2135)		.00139 (39)	

Series ML Features and Benefits

Series ML Cylinders >125mm Bore

A. Tie Rod Nuts

Heavy duty steel (zinc plated) sleeve nuts.

B. Cushioning

Heavy duty cushioning with fine adjustment is standard.

C. Piston Rod

High performance, high-strength, ground and polished 303 stainless steel, hard-chrome plated for excellent protection against wear.

D. Cushion Sleeves

Smooth operating polyamide cushion sleeves.

E. Tube

Precision aluminum tube ideally suited for air service. Anodized corrosion resistant surface.

F. Rod Seal Wiper

The combination seal/wiper design is molded from tough abrasion resistant materials for long life and ease of maintenance.

G. Bearing

Heavy duty long wearing nylon rod bearing.

H. Cushion Seal

One piece, nitrile compound seal. Linear and radial float of cushion seal eliminates misalignment. Designed to provide exceptionally fast out of cushion stroke reversal.

I. Piston Seals

Durable lip type

J. Piston

Wear band is standard. Optional magnetic piston for non-contact sensing. Seals are pressure energized and wear compensating.

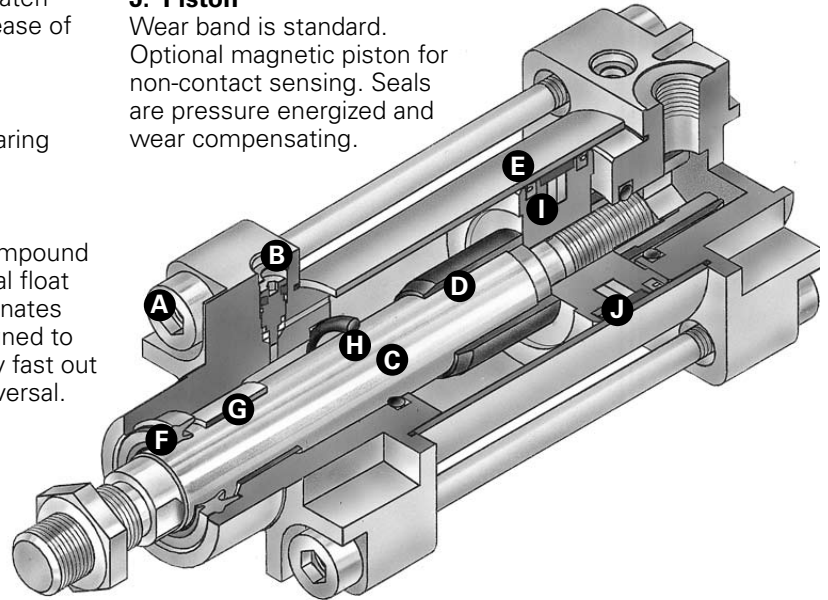

Series ML Cylinders <125mm Bore

A. Tie Rod Nuts

Heavy duty steel (zinc plated) sleeve nuts.

B. Cushioning

Heavy duty cushioning with fine adjustment is standard.

C. Piston Rod

High performance, high-strength, ground and polished 303 stainless steel, hard-chrome plated for excellent protection against wear.

D. Cushion Sleeves

Smooth operating polyamide cushion sleeves.

E. Tube

Precision aluminum profile tube with enclosed tie rods. Clear coat anodized corrosion resistant surface.

F. Rod Seal Wiper

The combination seal/wiper design is molded from tough abrasion resistant materials for long life and ease of maintenance.

G. Bearing

Heavy duty long wearing nylon rod bearing.

H. Cushion Seal

One piece, nitrile compound seal. Linear and radial float of cushion seal eliminates misalignment. Designed to provide exceptionally fast out of cushion stroke reversal.

J. Piston

Wear band is standard. Optional magnetic piston for non-contact sensing. Seals are pressure energized and wear compensating.

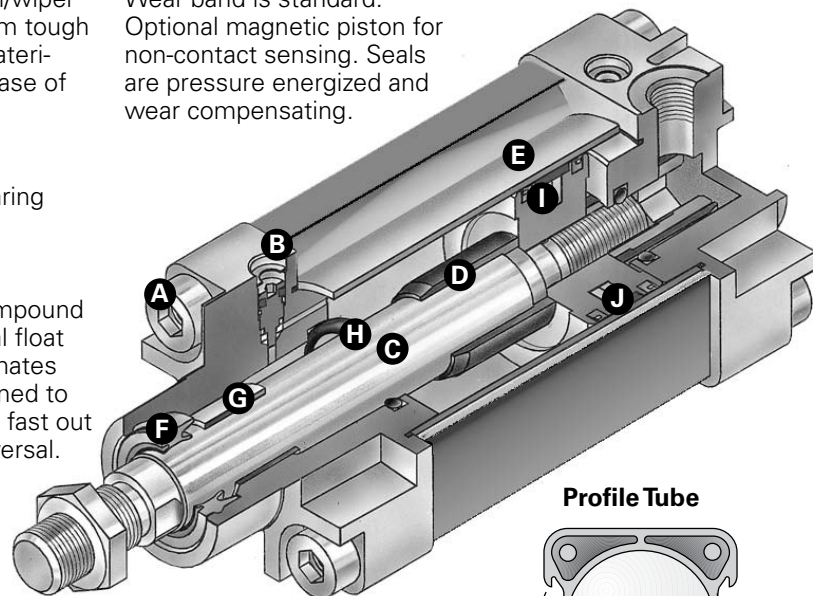

Profile Tube

Integral Switch Grooves
Tie Rod Construction

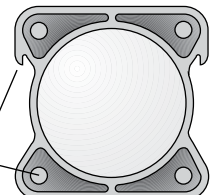

Series ML Model Code

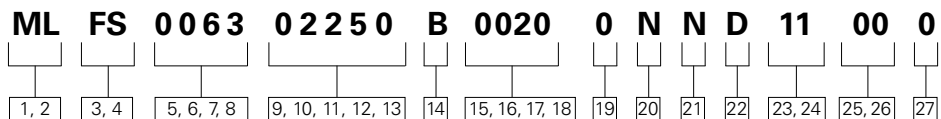

1, 2 Series

ML* – ISO 6431 /VDMA
24562

3, 4 Mounting Styles*

- FS – Head Rectangular Flange MF1
- RS – Cap Rectangular Flange MF2
- WS – Cap Trunnion MT5/6
- US – Head Trunnion MT5/6
- FM – Sleeve Nut for Tapped Face -
- KS – No Mounts -
- LS – Both Ends Extended Tie Rod MX1
- YY – Angle MS1
- DE – Cap Detachable Eye MP4
- DC – Cap Detachable Clevis MP2
- XX – Custom

* Mounting kits will be provided with cylinders when ordering specific mounting styles

5, 6, 7, 8 Bore

Specify in mm

- 0030 – 32mm bore
- 0040 – 40mm bore
- 0050 – 50mm bore
- 0063 – 63mm bore
- 0080 – 80mm bore
- 0100 – 100mm bore
- 0125 – 125mm bore
- 0160 – 160mm bore
- 0200 – 200mm bore
- 0250 – 250mm bore
- 0320 – 320mm bore

9, 10, 11, 12, 13 Stroke

Specify length in mm

Code	Length
00200	200mm
02250	2250mm

14 Cushions

Code	Location
B	Both Ends
C	Cap End
H	Head End
N	No Cushions

15, 16, 17, 18 Rod Diameter

Specify in mm

Code	Size
0012	12mm
0016	16mm
0020	20mm
0025	25mm
0032	32mm
0040	40mm
0050	50mm
0063	63mm

19 Rod End Type

Code	Type
0	Intermediate Male Metric

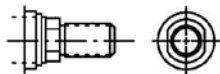

20 Ports

Code	Port Style
N	NPTF Standard
7	BSPPL

21 Rod Seals

- N – Nitrile Lip Type
- V – High Temperature

22 Piston Seals

- D – Low Friction
- V – High Temperature
- U – Ultra Cushioning Seal**
- N – Nitrile Lip Type

** Only available in 40, 50, 63, 80 mm bore

23, 24 Port Location

Code	Head	Cap
11	1	1

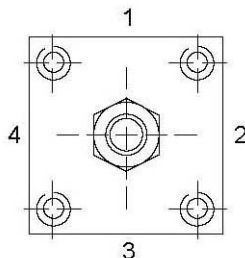

25, 26 Extra Rod Projection

Positions 25, 26 indicate extra rod projection in millimeters (mm), use 0-99 for this option.

– OR –

Proximity Switch Magnet

PK – Magnet Furnished to operate Hall Effect or Reed Type Switch

– OR –

Rod Boot
MN – Neoprene

– OR –

Rod Material Options
RT – Stainless Steel 300 Series

27 Custom

X – Custom Modification

* Cylinders <125mm bore have profile design, cylinders >125mm bore have tie rod design.

** Available in 40, 50, 63, 80mm bore cylinders

Series ML

Mounting Style: 32-320mm Bores

Available Mountings

The variety of standard DIN ISO 6431 / VDMA 24562 mountings available in the ML gives you a broad selection to match the proper mount to your application. Eaton offers rigid mounts (including extended tie rod mounts) and swivel mounts (including clevis and trunnion mounts). A guide to proper mount selection is provided on pages 72 through 88. For custom mounts, enter "XX" for model code positions 3 and 4, and give a detailed description with drawings. Series ML cylinders are available in all mounting styles listed.

Selecting the Proper Mounting

Just as the cylinder bore must be sized to provide the proper force for an application, a cylinder mounting that can absorb these application forces must also be specified. Note: In the mounting information, some mounts have been downrated to minimize deflection. For applications where the motion is linear and parallel to the cylinder rod motion, a rigid mount is recommended. For curvilinear motion, a swivel mount should be chosen. The specifics of each application dictate the correct mounting style.

Code FS Head Rectangular Flange (DIN ISO 6431 / VDMA 24562 Part 2, MF1)

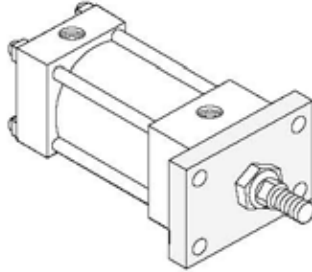

Code RS Cap Rectangular Flange (DIN ISO 6431 / VDMA 24562 Part 2, MF2)

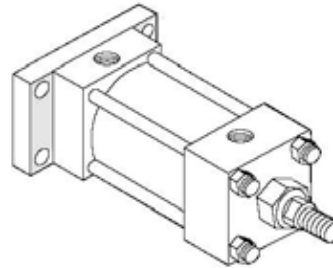

Code WS Cap Trunnion (VDMA 24562 Part 2, MT5/6)

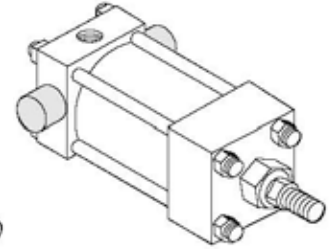

Code US Head Trunnion (VDMA 24562 Part 2, MT5/6)

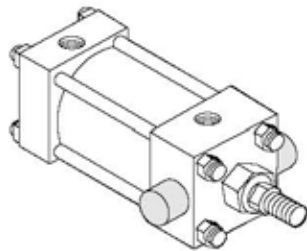

Code FM Sleeve Nut Construction for Tapped Face

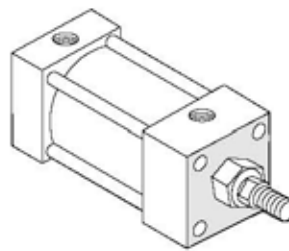

Code LS Extended Tie Rod (DIN ISO 6431, MX1)

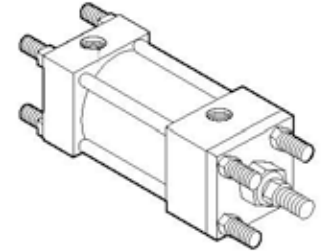

Code KS No Mounts

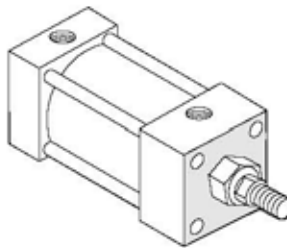

Code YY Angle (DIN ISO 6431, VDMA 24562 Part 2, MS1)

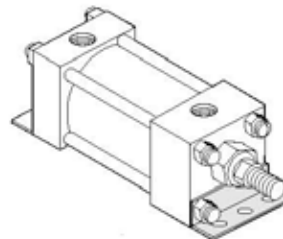

Code DE Cap Detachable Eye (DIN ISO 6431, VDMA 24562 Part 2, MP4)

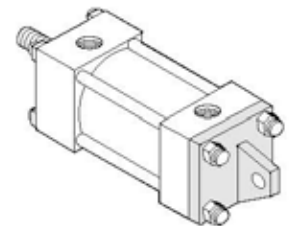

Code DC Cap Detachable Clevis (DIN ISO 6431, VDMA 24562 Part 2, MP2)

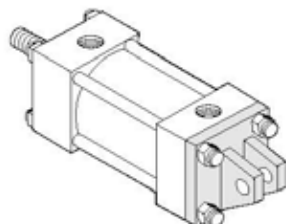

Series ML Mounting Styles and Installation Dimensions

32-320mm bore sizes

Code KS – No Mounts

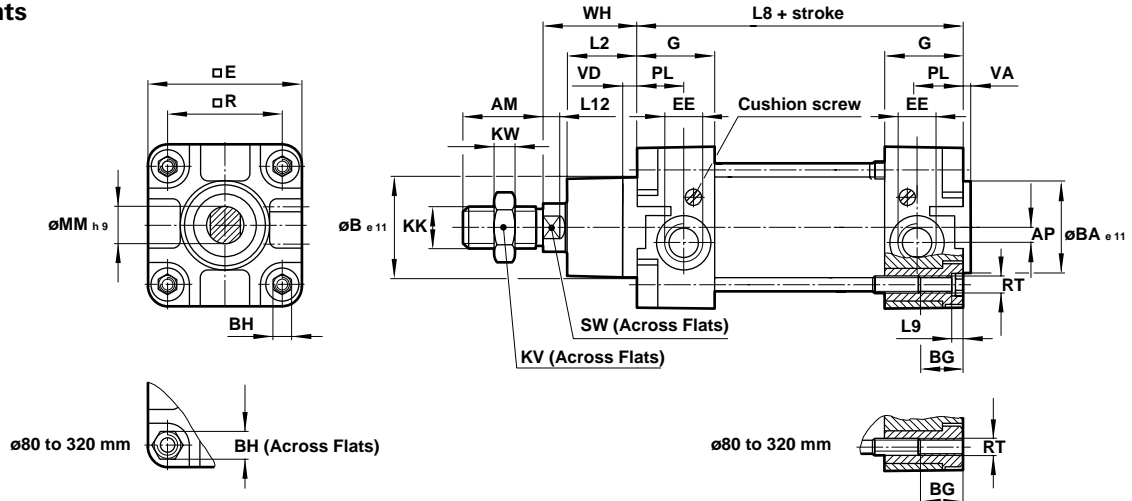

BORE	AM	AP	B	BA	BG	BH	E	EE	G	KK	KV	KW	L2	L8	L9
32	0.87 (22)	0.14 (3.5)	1.18 (30)	1.18 (30)	0.71 (18)	0.24 (6)	1.85 (47)	G 1/8 (1/8"NPT)	1.08 (27.5)	M10x1.25	0.67 (17)	0.20 (5)	0.79 (20)	3.70 (94)	0.16 (4)
40	0.94 (24)	0.18 (4.5)	1.38 (35)	1.38 (35)	0.71 (18)	0.24 (6)	2.09 (53)	G 1/4 (1/4"NPT)	1.26 (32)	M12x1.25	0.75 (19)	0.24 (6)	0.87 (22)	4.13 (105)	0.16 (4)
50	1.26 (32)	0.24 (6)	1.57 (40)	1.57 (40)	0.71 (18)	0.31 (8)	2.56 (65)	G 1/4 (1/4"NPT)	1.22 (31)	M16x1.5	0.94 (24)	0.31 (8)	1.06 (27)	4.17 (106)	0.20 (5)
63	1.26 (32)	0.39 (10)	1.77 (45)	1.77 (45)	0.69 (17.5)	0.31 (8)	2.95 (75)	G 3/8 (3/8"NPT)	1.30 (33)	M16x1.5	0.94 (24)	0.31 (8)	1.14 (29)	4.76 (121)	0.20 (5)
80	1.57 (40)	0.33 (8.5)	1.77 (45)	1.77 (45)	0.85 (21.5)	0.75 (19)	3.74 (95)	G 3/8 (3/8"NPT)	1.30 (33)	M20x1.5	1.18 (30)	0.39 (10)	1.30 (33)	5.04 (128)	–
100	1.57 (40)	0.35 (9)	2.17 (55)	2.17 (55)	0.85 (21.5)	0.75 (19)	4.53 (115)	G 1/2 (1/2"NPT)	1.46 (37)	M20x1.5	1.18 (30)	0.39 (10)	1.42 (36)	5.43 (138)	–
125	2.13 (54)	0.39 (10)	2.36 (60)	2.36 (60)	1.26 (32)	0.94 (24)	5.51 (140)	G 1/2 (1/2"NPT)	1.81 (46)	M27x2	1.61 (41)	0.53 (13.5)	1.77 (45)	6.30 (160)	–
160	2.83 (72)	0.71 (18)	2.56 (65)	2.56 (65)	1.12 (28.5)	1.26 (32)	7.22 (183.5)	G 3/4 (3/4"NPT)	1.97 (50)	M36x2	2.17 (55)	0.71 (18)	2.28 (58)	7.09 (180)	–
200	2.83 (72)	0.71 (18)	2.95 (75)	2.95 (75)	1.12 (28.5)	1.26 (32)	8.82 (224)	G 3/4 (3/4"NPT)	1.97 (50)	M36x2	2.17 (55)	0.71 (18)	2.64 (67)	7.09 (180)	–
250	3.31 (84)	0.89 (22.5)	3.54 (90)	3.54 (90)	1.38 (35)	1.42 (36)	11.02 (280)	G 1 (1"NPT)	2.28 (58)	M42x2	2.56 (65)	0.83 (21)	3.15 (80)	7.87 (200)	–
320	3.78 (96)	0.89 (22.5)	4.33 (110)	4.33 (110)	1.18 (30)	1.81 (46)	13.78 (350)	G 1 (1"NPT)	2.36 (60)	M48x2	2.95 (75)	0.94 (24)	3.54 (90)	8.66 (220)	–

BORE	L12	MM	PL	R	RT	SW	VA	VD	WH	8000		P/8000		PV/8000	
										WEIGHT AT ZERO STROKE	WEIGHT PER 25MM IN	WEIGHT AT ZERO STROKE	WEIGHT PER 25MM IN	WEIGHT AT ZERO STROKE	WEIGHT PER 25MM IN
										LBS (KG)	LBS (KG)	LBS (KG)	LBS (KG)	LBS (KG)	LBS (KG)
32	0.24 (6)	0.47 (12)	0.51 (13)	1.26 (32.5)	M 6	0.39 (10)	0.12 (3)	0.24 (6)	1.02 (26)	1.12 (0.51)	0.13 (0.06)	1.12 (0.51)	0.13 (0.06)	1.41 (0.64)	0.13 (0.06)
40	0.26 (6.5)	0.63 (16)	0.59 (15)	1.50 (38)	M 6	0.51 (13)	0.14 (3.5)	0.24 (6)	1.18 (30)	1.76 (0.80)	0.18 (0.08)	1.76 (0.80)	0.18 (0.08)	2.09 (0.95)	0.18 (0.08)
50	0.31 (8)	0.79 (20)	0.73 (18.5)	1.83 (46.5)	M 8	0.67 (17)	0.14 (3.5)	0.24 (6)	1.46 (37)	2.93 (1.33)	0.26 (0.12)	2.93 (1.33)	0.26 (0.12)	3.33 (1.51)	0.26 (0.12)
63	0.31 (8)	0.79 (20)	0.75 (19)	2.22 (56.5)	M 8	0.67 (17)	0.16 (4)	0.24 (6)	1.46 (37)	3.97 (1.80)	0.29 (0.13)	3.97 (1.80)	0.29 (0.13)	4.63 (2.10)	0.29 (0.13)
80	0.39 (10)	0.98 (25)	0.75 (19)	2.83 (72)	M 10	0.87 (22)	0.16 (4)	0.24 (6)	1.81 (46)	7.17 (3.25)	0.44 (0.20)	7.17 (3.25)	0.44 (0.20)	8.27 (3.75)	0.44 (0.20)
100	0.39 (10)	0.98 (25)	0.71 (18)	3.50 (89)	M 10	0.87 (22)	0.16 (4)	0.24 (6)	2.01 (51)	10.61 (4.81)	0.51 (0.23)	10.61 (4.81)	0.51 (0.23)	12.37 (5.61)	0.51 (0.23)
125	0.51 (13)	1.26 (32)	0.79 (20)	4.33 (110)	M 12	1.06 (27)	0.24 (6)	0.61 (15.5)	2.56 (65)	17.64 (8.00)	0.73 (0.33)	17.64 (8.00)	0.73 (0.33)	–	–
160	0.63 (16)	1.57 (40)	0.83 (21)	5.51 (140)	M 16	1.42 (36)	0.16 (4)	0.59 (15)	3.15 (80)	32.85 (14.9)	1.21 (0.55)	–	–	–	–
200	0.63 (16)	1.57 (40)	0.83 (21)	6.89 (175)	M 16	1.42 (36)	0.20 (5)	0.59 (15)	3.74 (95)	47.85 (21.7)	1.32 (0.60)	–	–	–	–
250	0.79 (20)	1.97 (50)	1.14 (29)	8.66 (220)	M 20	1.61 (41)	0.28 (7)	0.51 (13)	4.13 (105)	71.88 (32.6)	2.03 (0.92)	–	–	–	–
320	0.94 (24)	2.48 (63)	1.18 (30)	10.63 (270)	M 24	2.17 (55)	0.28 (7)	0.51 (13)	4.72 (120)	131.86 (59.8)	3.22 (1.46)	–	–	–	–

Dimensions in inches (mm)

Series ML Mounting Styles and Installation Dimensions

32-320mm bore sizes

Code FS – Head Rectangular Flange (DIN ISO 6431 / VDMA 24562 Part 2, MF1)

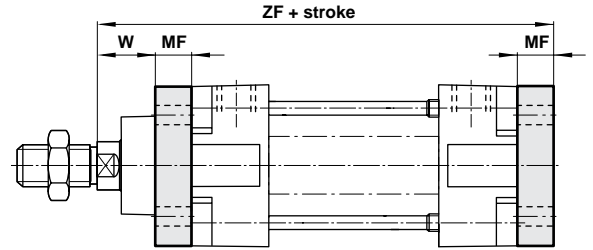
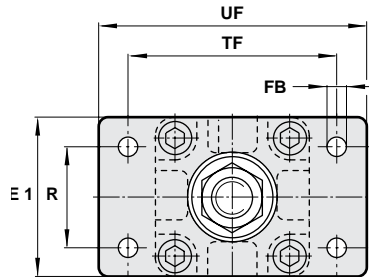

Code RS – Cap Rectangular Flange (DIN ISO 6431 / VDMA 24562 Part 2, MF2)

Code WS – Cap Trunnion (VDMA 24562 Part 2, MT5/6)

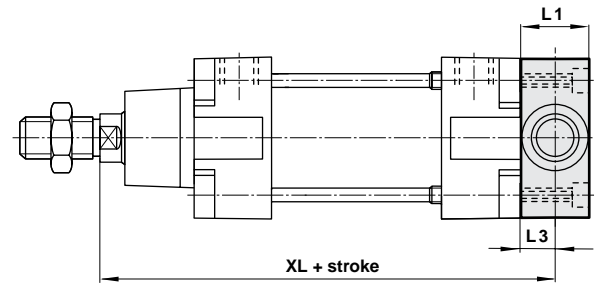
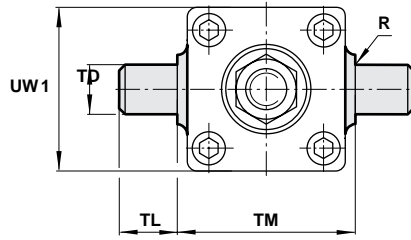

BORE	E1	FB	MF	R	TF	UF	W	ZF	WEIGHT* CODE 07, 12
32	1.97 (50)	0.28 (7)	0.39 (10)	1.26 (32)	2.52 (64)	3.15 (80)	0.63 (16)	5.12 (130)	0.55 (0.25)
40	2.17 (55)	0.35 (9)	0.39 (10)	1.42 (36)	2.83 (72)	3.54 (90)	0.79 (20)	5.71 (145)	0.77 (0.35)
50	2.56 (65)	0.35 (9)	0.47 (12)	1.77 (45)	3.54 (90)	4.33 (110)	0.98 (25)	6.10 (155)	1.54 (0.70)
63	2.95 (75)	0.35 (9)	0.47 (12)	1.97 (50)	3.94 (100)	4.92 (125)	0.98 (25)	6.69 (170)	1.76 (0.80)
80	3.94 (100)	0.47 (12)	0.63 (16)	2.48 (63)	4.96 (126)	6.06 (154)	1.18 (30)	7.48 (190)	2.98 (1.35)
100	4.72 (120)	0.55 (14)	0.63 (16)	2.95 (75)	5.91 (150)	7.32 (186)	1.38 (35)	8.07 (205)	4.85 (2.20)
125	5.51 (140)	0.63 (16)	0.79 (20)	3.54 (90)	7.09 (180)	8.82 (224)	1.77 (45)	9.65 (245)	3.75 (1.70)
160	7.09 (180)	0.71 (18)	0.79 (20)	4.53 (115)	9.06 (230)	11.02 (280)	2.36 (60)	11.02 (280)	6.84 (3.10)
200	8.66 (220)	0.87 (22)	0.98 (25)	5.31 (135)	10.63 (270)	12.60 (320)	2.76 (70)	11.81 (300)	10.14 (4.60)
250	11.02 (280)	1.02 (26)	0.98 (25)	6.50 (165)	12.99 (330)	15.55 (395)	3.15 (80)	12.99 (330)	16.32 (7.40)
320	13.78 (350)	1.30 (33)	1.18 (30)	7.87 (200)	15.75 (400)	18.70 (475)	3.54 (90)	14.57 (370)	29.99 (13.6)

BORE	L1	L3	R	TD	TL	TM	UW 1	XL	WEIGHT* CODE 16
32	0.63 (16)	0.31 (8)	0.04 (1)	0.47 (12)	0.47 (12)	1.97 (50)	1.97 (50)	5.04 (128)	0.44 (0.20)
40	0.79 (20)	0.39 (10)	0.06 (1.6)	0.63 (16)	0.63 (16)	2.48 (63)	2.17 (55)	5.71 (145)	0.84 (0.38)
50	0.94 (24)	0.47 (12)	0.06 (1.6)	0.63 (16)	0.63 (16)	2.95 (75)	2.56 (65)	6.10 (155)	1.32 (0.60)
63	0.94 (24)	0.47 (12)	0.06 (1.6)	0.79 (20)	0.79 (20)	3.54 (90)	2.95 (75)	6.69 (170)	2.43 (1.10)
80	1.10 (28)	0.55 (14)	0.06 (1.6)	0.79 (20)	0.79 (20)	4.33 (110)	3.94 (100)	7.40 (188)	4.19 (1.90)
100	1.50 (38)	0.75 (19)	0.08 (2)	0.98 (25)	0.98 (25)	5.20 (132)	4.72 (120)	8.19 (208)	7.72 (3.50)
125	1.97 (50)	0.98 (25)	0.08 (2)	0.98 (25)	0.98 (25)	6.30 (160)	5.71 (145)	9.84 (250)	14.33 (6.50)
160	—	—	0.10 (2.5)	1.26 (32)	1.26 (32)	7.87 (200)	—	—	—
200	—	—	0.10 (2.5)	1.26 (32)	1.26 (32)	9.84 (250)	—	—	—
250	—	—	0.13 (3.2)	1.57 (40)	1.57 (40)	12.60 (320)	—	—	—
320	—	—	0.13 (3.2)	1.97 (50)	1.97 (50)	15.75 (400)	—	—	—

*All weights in pounds (Kilograms)
Dimensions in inches (mm)

Series ML Mounting Styles and Installation Dimensions

32-320mm bore sizes

Code US – Head Trunnion
(VDMA 24562 Part 2, Style
MT5/6)

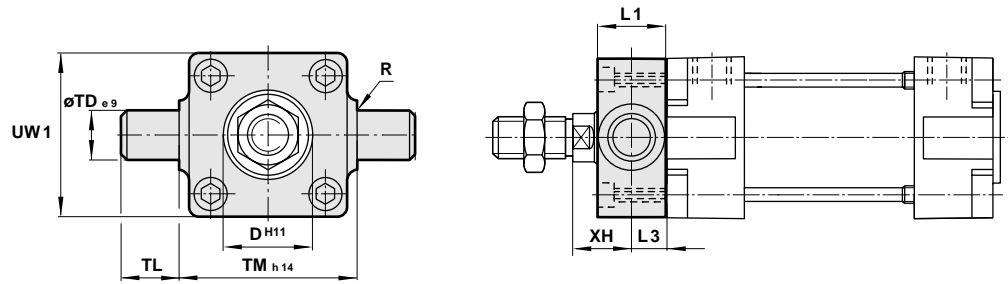

BORE	D	L1	L3	R	TD	TL	TM	UW 1	XH	WEIGHT* CODE 17
32	1.18 (30)	0.63 (16)	0.31 (8)	0.04 (1)	0.47 (12)	0.47 (12)	1.97 (50)	1.97 (50)	0.71 (18)	0.44 (0.20)
40	1.38 (35)	0.79 (20)	0.39 (10)	0.06 (1.6)	0.63 (16)	0.63 (16)	2.48 (63)	2.17 (55)	0.79 (20)	0.84 (0.38)
50	1.57 (40)	0.94 (24)	0.47 (12)	0.06 (1.6)	0.63 (16)	0.63 (16)	2.95 (75)	2.56 (65)	0.98 (25)	1.32 (0.60)
63	1.77 (45)	0.94 (24)	0.47 (12)	0.06 (1.6)	0.79 (20)	0.79 (20)	3.54 (90)	2.95 (75)	0.98 (25)	2.43 (1.10)
80	1.77 (45)	1.10 (28)	0.55 (14)	0.06 (1.6)	0.79 (20)	0.79 (20)	4.33 (110)	3.94 (100)	1.26 (32)	4.19 (1.90)
100	2.17 (55)	1.50 (38)	0.75 (19)	0.08 (2)	0.98 (25)	0.98 (25)	5.20 (132)	4.72 (120)	1.26 (32)	7.72 (3.50)
125	2.36 (60)	1.97 (50)	0.98 (25)	0.08 (2)	0.98 (25)	0.98 (25)	6.30 (160)	5.71 (145)	1.57 (40)	14.33 (6.50)
160	—	—	—	0.10 (2.5)	1.26 (32)	1.26 (32)	7.87 (200)	—	—	—
200	—	—	—	0.10 (2.5)	1.26 (32)	1.26 (32)	9.84 (250)	—	—	—
250	—	—	—	0.13 (3.2)	1.57 (40)	1.57 (40)	12.60 (320)	—	—	—
320	—	—	—	0.13 (3.2)	1.97 (50)	1.97 (50)	15.75 (400)	—	—	—

*All weights in pounds (Kilograms)

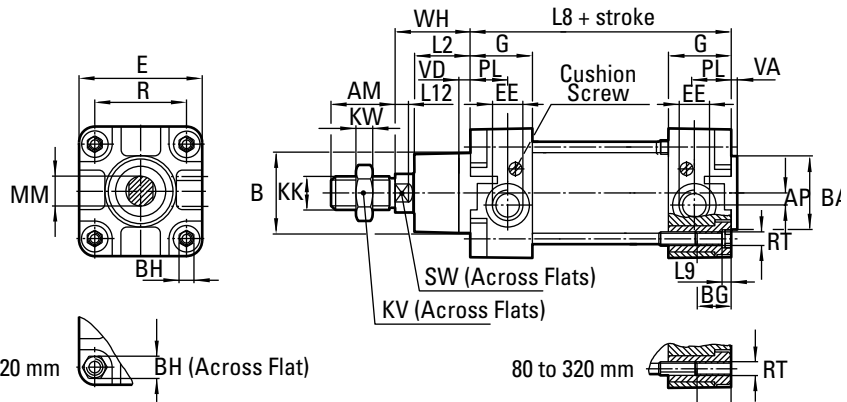

Code FM – Sleeve Nut
Construction for Tapped
Face

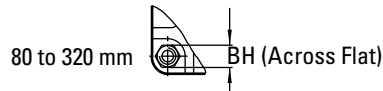

BORE	AM	AP	B	BA	BG	BH	E	EE	G	KK	KV	KW	L2	BG	L8	L9
32	0.87 (22)	0.14 (3.5)	1.18 (30)	1.18 (30)	0.71 (18)	0.24 (6)	1.85 (47)	G 1/8 (1/8"NPT)	1.08 (27.5)	M10x1.25	0.67 (17)	0.20 (5)	0.79 (20)	3.70 (94)	0.16 (4)	
40	0.94 (24)	0.18 (4.5)	1.38 (35)	1.38 (35)	0.71 (18)	0.24 (6)	2.09 (53)	G 1/4 (1/4"NPT)	1.26 (32)	M12x1.25	0.75 (19)	0.24 (6)	0.87 (22)	4.13 (105)	0.16 (4)	
50	1.26 (32)	0.24 (6)	1.57 (40)	1.57 (40)	0.71 (18)	0.31 (8)	2.56 (65)	G 1/4 (1/4"NPT)	1.22 (31)	M16x1.5	0.94 (24)	0.31 (8)	1.06 (27)	4.17 (106)	0.20 (5)	
63	1.26 (32)	0.39 (10)	1.77 (45)	1.77 (45)	0.69 (17.5)	0.31 (8)	2.95 (75)	G 3/8 (3/8"NPT)	1.30 (33)	M16x1.5	0.94 (24)	0.31 (8)	1.14 (29)	4.76 (121)	0.20 (5)	
80	1.57 (40)	0.33 (8.5)	1.77 (45)	1.77 (45)	0.85 (21.5)	0.75 (19)	3.74 (95)	G 3/8 (3/8"NPT)	1.30 (33)	M20x1.5	1.18 (30)	0.39 (10)	1.30 (33)	5.04 (128)	—	
100	1.57 (40)	0.35 (9)	2.17 (55)	2.17 (55)	0.85 (21.5)	0.75 (19)	4.53 (115)	G 1/2 (1/2"NPT)	1.46 (37)	M20x1.5	1.18 (30)	0.39 (10)	1.42 (36)	5.43 (138)	—	
125	2.13 (54)	0.39 (10)	2.36 (60)	2.36 (60)	1.26 (32)	0.94 (24)	5.51 (140)	G 1/2 (1/2"NPT)	1.81 (46)	M27x2	1.61 (41)	0.53 (13.5)	1.77 (45)	6.30 (160)	—	
160	2.83 (72)	0.71 (18)	2.56 (65)	2.56 (65)	1.12 (28.5)	1.26 (32)	7.22 (183.5)	G 3/4 (3/4"NPT)	1.97 (50)	M36x2	2.17 (55)	0.71 (18)	2.28 (58)	7.09 (180)	—	
200	2.83 (72)	0.71 (18)	2.95 (75)	2.95 (75)	1.12 (28.5)	1.26 (32)	8.82 (224)	G 3/4 (3/4"NPT)	1.97 (50)	M36x2	2.17 (55)	0.71 (18)	2.64 (67)	7.09 (180)	—	
250	3.31 (84)	0.89 (22.5)	3.54 (90)	3.54 (90)	1.38 (35)	1.42 (36)	11.02 (280)	G 1 (1"NPT)	2.28 (58)	M42x2	2.56 (65)	0.83 (21)	3.15 (80)	7.87 (200)	—	
320	3.78 (96)	0.89 (22.5)	4.33 (110)	4.33 (110)	1.18 (30)	1.81 (46)	13.78 (350)	G 1 (1"NPT)	2.36 (60)	M48x2	2.95 (75)	0.94 (24)	3.54 (90)	8.66 (220)	—	

BORE	L12	MM	PL	R	RT	SW	VA	VD	WH	8000		P/8000		PV/8000	
										WEIGHT AT ZERO STROKE	WEIGHT PER 25MM IN	WEIGHT AT ZERO STROKE	WEIGHT PER 25MM IN	WEIGHT AT ZERO STROKE	WEIGHT PER 25MM IN
										LBS(KG)	LBS(KG)	LBS(KG)	LBS(KG)	LBS(KG)	LBS(KG)
32	0.24 (6)	0.47 (12)	0.51 (13)	1.26 (32.5)	M 6	0.39 (10)	0.12 (3)	0.24 (6)	1.02 (26)	1.12 (0.51)	0.13 (0.06)	1.12 (0.51)	0.13 (0.06)	1.41 (0.64)	0.13 (0.06)
40	0.26 (6.5)	0.63 (16)	0.59 (15)	1.50 (38)	M 6	0.51 (13)	0.14 (3.5)	0.24 (6)	1.18 (30)	1.76 (0.80)	0.18 (0.08)	1.76 (0.80)	0.18 (0.08)	2.09 (0.95)	0.18 (0.08)
50	0.31 (8)	0.79 (20)	0.73 (18.5)	1.83 (46.5)	M 8	0.67 (17)	0.14 (3.5)	0.24 (6)	1.46 (37)	2.93 (1.33)	0.26 (0.12)	2.93 (1.33)	0.26 (0.12)	3.33 (1.51)	0.26 (0.12)
63	0.31 (8)	0.79 (20)	0.75 (19)	2.22 (56.5)	M 8	0.67 (17)	0.16 (4)	0.24 (6)	1.46 (37)	3.97 (1.80)	0.29 (0.13)	3.97 (1.80)	0.29 (0.13)	4.63 (2.10)	0.29 (0.13)
80	0.39 (10)	0.98 (25)	0.75 (19)	2.83 (72)	M 10	0.87 (22)	0.16 (4)	0.24 (6)	1.81 (46)	7.17 (3.25)	0.44 (0.20)	7.17 (3.25)	0.44 (0.20)	8.27 (3.75)	0.44 (0.20)
100	0.39 (10)	0.98 (25)	0.71 (18)	3.50 (89)	M 10	0.87 (22)	0.16 (4)	0.24 (6)	2.01 (51)	10.61 (4.81)	0.51 (0.23)	10.61 (4.81)	0.51 (0.23)	12.37 (5.61)	0.51 (0.23)
125	0.51 (13)	1.26 (32)	0.79 (20)	4.33 (110)	M 12	1.06 (27)	0.24 (6)	0.61 (15.5)	2.56 (65)	17.64 (8.00)	0.73 (0.33)	17.64 (8.00)	0.73 (0.33)	—	—
160	0.63 (16)	1.57 (40)	0.83 (21)	5.51 (140)	M 16	1.42 (36)	0.16 (4)	0.59 (15)	3.15 (80)	32.85 (14.9)	1.21 (0.55)	—	—	—	—
200	0.63 (16)	1.57 (40)	0.83 (21)	6.89 (175)	M 16	1.42 (36)	0.20 (5)	0.59 (15)	3.74 (95)	47.85 (21.7)	1.32 (0.60)	—	—	—	—
250	0.79 (20)	1.97 (50)	1.14 (29)	8.66 (220)	M 20	1.61 (41)	0.28 (7)	0.51 (13)	4.13 (105)	71.88 (32.6)	2.03 (0.92)	—	—	—	—
320	0.94 (24)	2.48 (63)	1.18 (30)	10.63 (270)	M 24	2.17 (55)	0.28 (7)	0.51 (13)	4.72 (120)	131.86 (59.8)	3.22 (1.46)	—	—	—	—

Series ML Mounting Styles and Installation Dimensions

32-320mm bore sizes

Code LS – Extended Tie Rod (DIN ISO 6431, MX1)

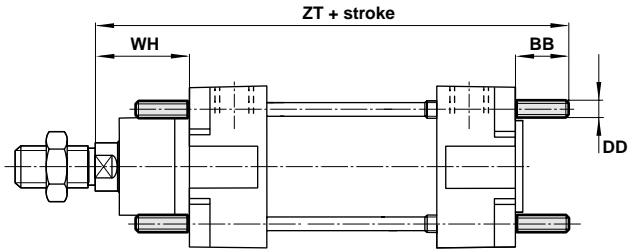
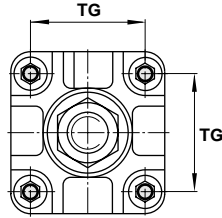

Code YY Angle (DIN ISO 6431, VDMA 24562 Part 2, MS1)

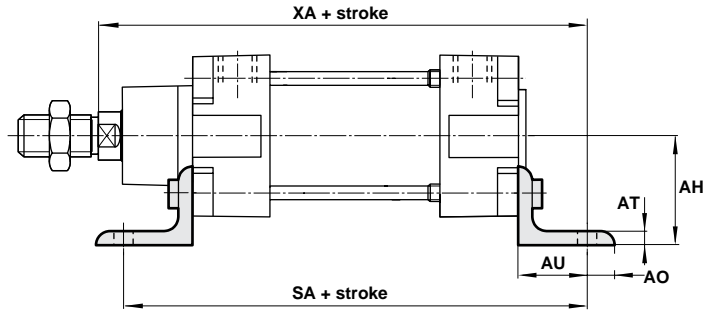
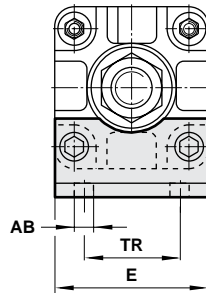

BORE	AB	AH	AO	AT	AU	BB	DD	E	SA
32	0.28 (7)	1.26 (32)	0.31 (8)	0.16 (4)	0.94 (24)	0.67 (17)	M 6	1.89 (48)	5.59 (142)
40	0.35 (9)	1.42 (36)	0.35 (9)	0.16 (4)	1.10 (28)	0.67 (17)	M 6	2.09 (53)	6.34 (161)
50	0.35 (9)	1.77 (45)	0.39 (10)	0.20 (5)	1.26 (32)	0.91 (23)	M 8	2.52 (64)	6.69 (170)
63	0.35 (9)	1.97 (50)	0.47 (12)	0.20 (5)	1.26 (32)	0.91 (23)	M 8	2.91 (74)	7.28 (185)
80	0.47 (12)	2.48 (63)	0.75 (19)	0.20 (5)	1.61 (41)	1.10 (28)	M 10	3.86 (98)	8.27 (210)
100	0.55 (14)	2.80 (71)	0.75 (19)	0.20 (5)	1.61 (41)	1.10 (28)	M 10	4.53 (115)	8.66 (220)
125	0.63 (16)	3.54 (90)	0.79 (20)	0.35 (9)	1.77 (45)	1.34 (34)	M 12	5.51 (140)	9.84 (250)
160	0.71 (18)	4.53 (115)	0.79 (20)	0.31 (8)	2.36 (60)	1.65 (42)	M 16	7.09 (180)	11.81 (300)
200	0.87 (22)	5.31 (135)	1.18 (30)	0.35 (9)	2.76 (70)	1.65 (42)	M 16	8.66 (220)	12.60 (320)
250	1.02 (26)	6.50 (165)	1.38 (35)	0.39 (10)	2.95 (75)	1.97 (50)	M 20	11.02 (280)	13.78 (350)
320	1.30 (33)	7.87 (200)	1.77 (45)	0.63 (16)	3.35 (85)	2.36 (60)	M 24	13.78 (350)	15.35 (390)

BORE	TG	TR	WH	XA	ZT	WEIGHT* CODE 23	WEIGHT* CODE 45
32	1.28 (32.5)	1.26 (32)	1.02 (26)	5.67 (144)	5.39 (137)	0.04 (0.02)	0.33 (0.15)
40	1.50 (38)	1.42 (36)	1.18 (30)	6.42 (163)	5.98 (152)	0.04 (0.02)	0.40 (0.18)
50	1.83 (46.5)	1.77 (45)	1.46 (37)	6.89 (175)	6.54 (166)	0.11 (0.05)	0.66 (0.30)
63	2.22 (56.5)	1.97 (50)	1.46 (37)	7.48 (190)	7.13 (181)	0.11 (0.05)	0.86 (0.39)
80	2.83 (72)	2.48 (63)	1.81 (46)	8.46 (215)	7.95 (202)	0.18 (0.08)	1.76 (0.80)
100	3.50 (89)	2.95 (75)	2.01 (51)	9.06 (230)	8.54 (217)	0.18 (0.08)	2.09 (0.95)
125	4.33 (110)	3.54 (90)	2.56 (65)	10.63 (270)	10.20 (259)	0.31 (0.14)	5.29 (2.40)
160	5.51 (140)	4.53 (115)	3.15 (80)	12.60 (320)	11.89 (302)	0.68 (0.31)	7.72 (3.50)
200	6.89 (175)	5.31 (135)	3.74 (95)	13.58 (345)	12.48 (317)	0.68 (0.31)	11.58 (5.25)
250	8.66 (220)	6.50 (165)	4.13 (105)	14.96 (380)	13.98 (355)	2.03 (0.92)	20.95 (9.50)
320	10.63 (270)	7.87 (200)	4.72 (120)	16.73 (425)	15.75 (400)	3.22 (1.46)	48.51 (22.0)

*All weights in pounds (Kilograms)
Dimensions in inches (mm)

Series ML Mounting Styles and Installation Dimensions

32-320mm bore sizes

Code DE Cap Detachable Eye (DIN ISO 6431, VDMA 24562 Part 2, MP4)

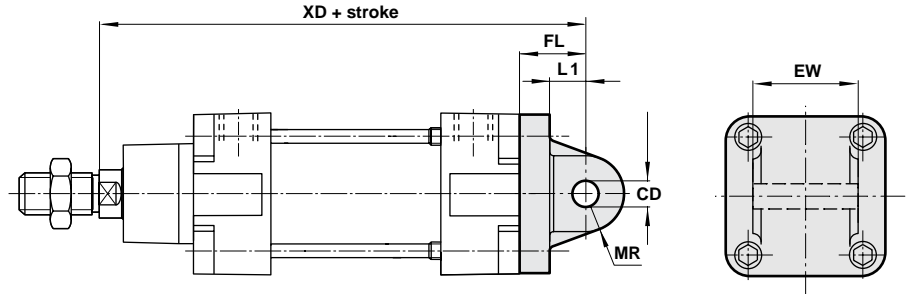

Code DC Cap Detachable Clevis (DIN ISO 6431, VDMA 24562 Part 2, MP2)

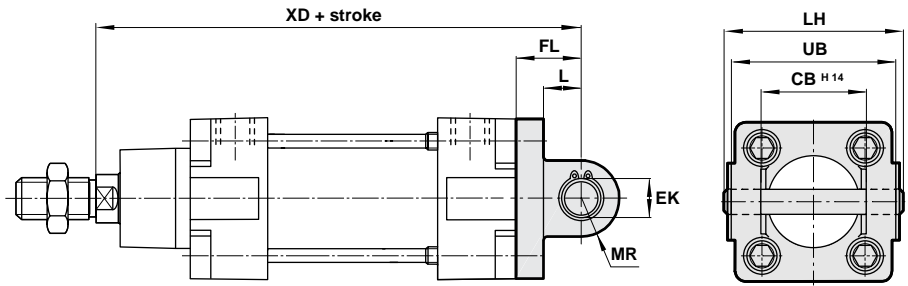









BORE	CD	EW	FL	L1	MR	XD	WEIGHT* CODE 48
32	0.39 (10)	1.02 (25.8)	0.87 (22)	0.51 (13)	0.35 (9)	5.59 (142)	0.20 (0.09)
40	0.47 (12)	1.09 (27.8)	0.98 (25)	0.63 (16)	0.47 (12)	6.30 (160)	0.24 (0.11)
50	0.47 (12)	1.25 (31.7)	1.06 (27)	0.67 (17)	0.47 (12)	6.69 (170)	0.37 (0.17)
63	0.63 (16)	1.56 (39.7)	1.26 (32)	0.87 (22)	0.59 (15)	7.48 (190)	0.53 (0.24)
80	0.63 (16)	1.96 (49.7)	1.42 (36)	0.87 (22)	0.59 (15)	8.27 (210)	0.82 (0.37)
100	0.79 (20)	2.35 (59.7)	1.61 (41)	1.06 (27)	0.79 (20)	9.06 (230)	1.30 (0.59)
125	0.98 (25)	2.74 (69.7)	1.97 (50)	1.30 (33)	0.98 (25)	10.83 (275)	7.06 (3.20)
160	1.18 (30)	3.53 (89.7)	2.17 (55)	1.40 (35.5)	1.18 (30)	12.40 (315)	13.45 (6.10)
200	1.18 (30)	3.53 (89.7)	2.36 (60)	1.46 (37)	1.18 (30)	13.19 (335)	14.99 (6.80)





BORE	CB	EK	FL	L	LH	MR	UB	XD	WEIGHT* CODE 50
32	1.02 (26)	0.39 (10)	0.87 (22)	0.51 (13)	2.05 (52)	0.35 (9)	1.77 (45)	5.59 (142)	0.24 (0.11)
40	1.10 (28)	0.47 (12)	0.98 (25)	0.63 (16)	2.36 (60)	0.47 (12)	2.05 (52)	6.30 (160)	0.35 (0.16)
50	1.26 (32)	0.47 (12)	1.06 (27)	0.67 (17)	2.68 (68)	0.47 (12)	2.36 (60)	6.69 (170)	0.49 (0.22)
63	1.57 (40)	0.63 (16)	1.26 (32)	0.87 (22)	3.11 (79)	0.59 (15)	2.76 (70)	7.48 (190)	0.75 (0.34)
80	1.97 (50)	0.63 (16)	1.42 (36)	0.87 (22)	3.90 (99)	0.59 (15)	3.54 (90)	8.27 (210)	1.19 (0.54)
100	2.36 (60)	0.79 (20)	1.61 (41)	1.06 (27)	4.69 (119)	0.79 (20)	4.33 (110)	9.06 (230)	1.98 (0.90)
125	2.76 (70)	0.98 (25)	1.97 (50)	1.22 (31)	5.47 (139)	0.98 (25)	5.12 (130)	10.83 (275)	5.95 (2.70)
160	3.54 (90)	1.18 (30)	2.17 (55)	1.40 (35.5)	7.13 (181)	1.18 (30)	6.69 (170)	12.40 (315)	9.48 (4.30)
200	3.54 (90)	1.18 (30)	2.36 (60)	1.41 (36)	7.13 (181)	1.18 (30)	6.69 (170)	13.19 (335)	13.45 (6.10)
250	4.33 (110)	1.57 (40)	2.76 (70)	1.77 (45)	8.60 (218)	1.57 (40)	7.87 (200)	14.76 (375)	41.90 (19.0)
320	4.72 (120)	1.77 (45)	3.15 (80)	1.97 (50)	9.37 (238)	1.77 (45)	8.66 (220)	16.54 (420)	67.25 (30.5)

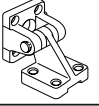
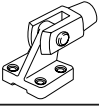
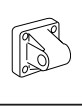
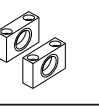
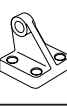

*All weights in pounds (Kilograms)

Dimensions in inches (mm)

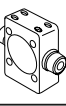
Series ML Cylinder Accessories

	TIE ROD STUDS	PISTON ROD SWIVEL	FLANGE MOUNTING PLATE	FOOT MOUNTING	REAR CLEVIS MOUNT TYPE 1	REAR CLEVIS MOUNT TYPE 2	PISTON ROD CLEVIS MOUNTING	FRONT OR REAR DETACHABLE TRUNNION MOUNTING	CENTER TRUNNION MOUNTING
									
32	ML/8032/35	ML/8025/38	ML/86012A	ML/8032/21	ML/61012A	ML/61M012A	ML62012A	ML/84012A	ML84M012A
40	ML/8032/35	ML/8040/38	ML/86016A	ML/8040/21	ML/61016A	ML/61M016A	ML62016A	ML/84016A	ML84M016A
50	ML/8050/35	ML/8050/38	ML/86020A	ML/8050/21	ML/61020A	ML/61M020A	ML62020A	ML/84020A	ML84M020A
63	ML/8050/35	ML/8050/38	ML/86025A	ML/8063/21	ML/61025A	ML/61M025A	ML62025A	ML/84025A	ML84M032A
80	ML/8080/35	ML/8080/38	ML/86032A	ML/8080/21	ML/61032A	ML/61M032A	ML62032A	ML/84032A	ML84M032A
100	ML/8080/35	ML/8080/38	ML/86040A	ML/8100/21	ML/61040A	ML/61M040A	ML62040A	ML/84040A	ML84M040A
125	ML/8125/35	ML/8125/38	ML/86050A	ML/8125/21	ML/61050A	ML/61M050A	ML62050A	ML/84050A	ML84M050A
160	ML/8160/35	ML/8160/38	ML/86064A	ML/8160/21	ML/61064A	ML/61M064A	ML62064A	–	ML84M064A
200	ML/8160/35	ML/8160/38	ML/86080A	ML/8200/21	ML/61080A	ML/61M080A	ML62080A	–	ML84M080A
250	ML/8250/35	–	ML/86100A	ML/8250/21	ML/61100A	ML/61M100A	ML62100A	–	ML84M100A
320	ML/8320/35	–	ML/86128A	ML/8320/21	ML/61128A	ML/61M128A	ML62128A	–	ML84M128A

	REAR HINGE MOUNT TYPE 1	FRONT HINGE MOUNTING	REAR EYE MOUNTING	TRUNNION SUPPORT MOUNTING	NARROW HINGE	WIDE HINGE	UNIVERSAL PISTON ROD-EYE	ADJUSTABLE CENTER TRUNNION	REAR HINGE MOUNT TYPE 2
									
32	ML/8032/24	ML/8032/26	ML/78012A	ML/8032/26	ML/P19931	ML/P19493	ML/60010A	ML/84N012A	ML/8032/43
40	ML/8040/24	ML/8040/26	ML/78016A	ML/8040/26	ML/P19932	ML/P19494	ML/60016A	ML/84N016A	ML/8040/43
50	ML/8050/24	ML/8050/26	ML/78020A	ML/8040/26	ML/P19933	ML/P19495	ML/60020A	ML/84N020A	ML/8050/43
63	ML/8063/24	ML/8063/26	ML/78025A	ML/8063/26	ML/P19934	ML/P19496	ML/60020A	ML/84N025A	ML/8063/43
80	ML/8080/24	ML/8080/26	ML/78032A	ML/8063/26	ML/P19935	ML/P19497	ML/60032A	ML/84N032A	ML/8080/43
100	ML/8100/24	ML/8100/26	ML/78040A	ML/8100/26	ML/P19936	ML/P19498	ML/60032A	ML/84N040A	ML/8100/43
125	ML/8125/24	ML/8125/26	ML/78050A	ML/8100/26	ML/P19937	ML/P19499	ML/60050A	ML/84N050A	ML/8125/43
160	ML/8160/24	ML/8160/26	ML/78064A	ML/8160/26	ML/P19938	ML/P19679	ML/60064A	ML/84N064A	ML/8160/43
200	ML/8200/24	ML/8200/26	ML/78080A	ML/8160/26	ML/P19939	ML/P19683	ML/60064A	ML/84N080A	ML/8200/43
250	ML/8250/24	–	–	–	–	ML/P19446	ML/60100A	–	–
320	ML/8320/24	–	–	–	–	ML/P19447	ML/60128A	–	–

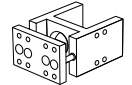
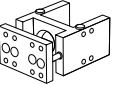
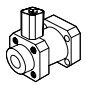
	UNIVERSAL REAR-EYE	SWIVEL HINGE	GUIDE BLOCKS	GUIDE BLOCKS	LOCKING UNIT (PASSIVE)
					
32	ML/8032/33	ML/P40310	ML/8032/51/*	ML/8032/61/*	ML/8032/59
40	ML/8040/33	ML/P40311	ML/8040/51/*	ML/8040/61/*	ML/8040/59
50	ML/8050/33	ML/P40312	ML/8050/51/*	ML/8050/61/*	ML/8050/59
63	ML/8063/33	ML/P40313	ML/8063/51/*	ML/8063/61/*	ML/8063/59
80	ML/8080/33	ML/P40314	ML/8080/51/*	ML/8080/61/*	ML/8080/59
100	ML/8100/33	ML/P40315	ML/8100/51/*	ML/8100/61/*	ML/8100/59
125	ML/8125/33	ML/P71355	–	–	ML/8125/59
160	ML/8160/33	ML/P71356	–	–	–
200	ML/8200/33	ML/P71357	–	–	–
250	–	–	–	–	–
320	–	–	–	–	–

Series ML Cylinder Accessories

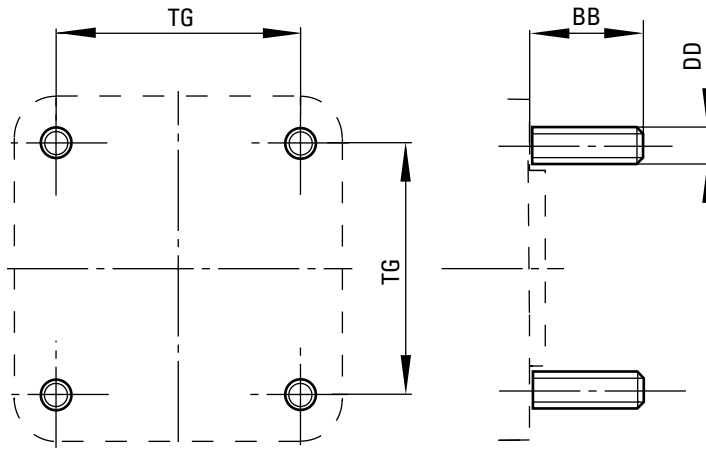

Tie Rod Studs mounting – A ISO 6431

BORE	BB	DD	TG
32	.67 (17)	M6	1.28 (32.5)
40	.67 (17)	M6	1.50 (38)
50	.91 (23)	M8	1.83 (46.5)
63	.91 (23)	M8	2.22 (56.5)
80	1.10 (28)	M10	2.83 (72)
100	1.10 (28)	M10	3.50 (89)
125	1.34 (34)	M12	4.33 (110)
160	1.65 (42)	M16	5.51 (140)
200	1.65 (42)	M16	6.89 (175)
250	1.97 (50)	M20	8.66 (220)
320	2.36 (60)	M24	10.63 (270)

Dimensions in inches (mm)

Piston rod swivel mounting

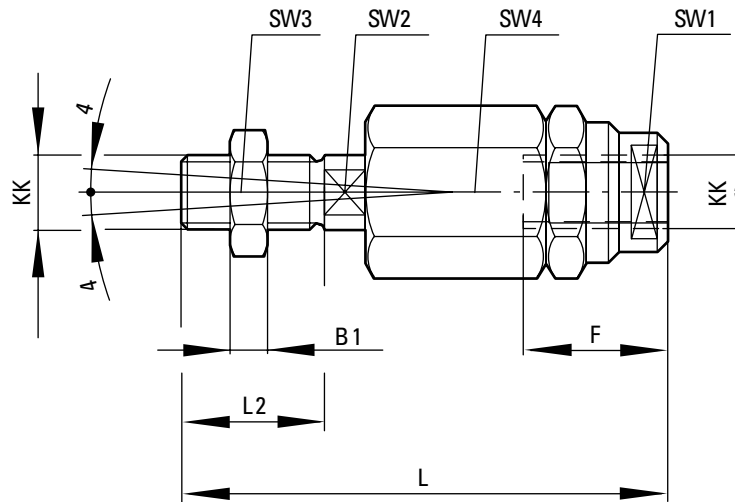

BORE	B1	F	KK	L2	SW 1	SW 2	SW 3	SW 4
32	0.20 (5)	1.02 (26)	M 10 x 1.25	0.79 (20)	0.75 (19)	0.47 (12)	0.67 (17)	1.18 (30)
40	0.24 (6)	1.02 (26)	M 12 x 1.25	0.94 (24)	0.75 (19)	0.47 (12)	0.75 (19)	1.18 (30)
50	0.31 (8)	1.34 (34)	M 16 x 1.5	1.26 (32)	1.18 (30)	0.75 (19)	0.94 (24)	1.65 (42)
63	0.31 (8)	1.34 (34)	M 16 x 1.5	1.26 (32)	1.18 (30)	0.75 (19)	0.94 (24)	1.65 (42)
80	0.39 (10)	1.65 (42)	M 20 x 1.5	1.57 (40)	1.18 (30)	0.75 (19)	1.18 (30)	1.65 (42)
100	0.39 (10)	1.65 (42)	M 20 x 1.5	1.57 (40)	1.18 (30)	0.75 (19)	1.18 (30)	1.65 (42)
125	0.53 (13.5)	1.57 (40)	M 27 x 2	2.13 (54)	1.57 (40)	0.94 (24)	1.61 (41)	2.17 (55)
160	0.71 (18)	3.07 (78)	M 36 x 2	2.83 (72)	1.97 (50)	1.42 (36)	2.17 (55)	2.95 (75)
200	0.71 (18)	3.07 (78)	M 36 x 2	2.83 (72)	1.97 (50)	1.42 (36)	2.17 (55)	2.95 (75)
250	—	—	M 42 x 2	—	—	—	—	—
320	—	—	M 48 x 2	—	—	—	—	—

Dimensions in inches (mm)

Series ML Cylinder Accessories

Rear or Front flange Mounting – ISO 6431 and VDMA 24562 Part 2

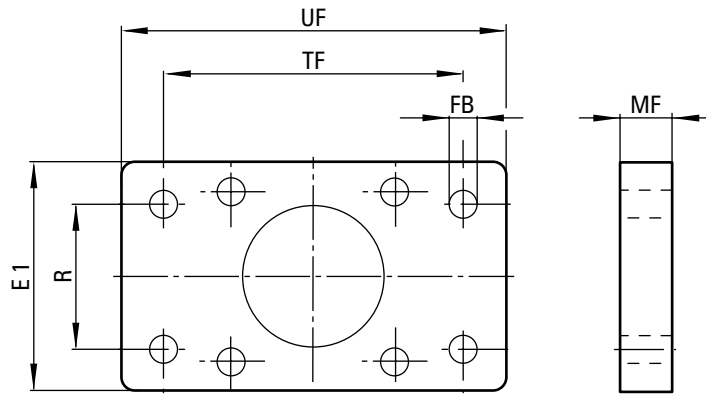

BORE	E1	FB	MF	R	TF	UF
32	1.97 (50)	0.28 (7)	0.39 (10)	1.26 (32)	2.52 (64)	3.15 (80)
40	2.17 (55)	0.35 (9)	0.39 (10)	1.42 (36)	2.83 (72)	3.54 (90)
50	2.56 (65)	0.35 (9)	0.47 (12)	1.77 (45)	3.54 (90)	4.33 (110)
63	2.95 (75)	0.35 (9)	0.47 (12)	1.97 (50)	3.94 (100)	4.92 (125)
80	03.94 (100)	0.47 (12)	0.63 (16)	2.48 (63)	4.96 (126)	6.06 (154)
100	4.72 (120)	0.55 (14)	0.63 (16)	2.95 (75)	5.91 (150)	7.32 (186)
125	5.51 (140)	0.63 (16)	0.79 (20)	3.54 (90)	7.09 (180)	8.82 (224)
160	7.09 (180)	0.71 (18)	0.79 (20)	4.53 (115)	9.06 (230)	11.02 (280)
200	08.66 (220)	0.87 (22)	0.98 (25)	5.31 (135)	10.63 (270)	12.60 (320)
250	11.02 (280)	1.02 (26)	0.98 (25)	6.50 (165)	12.99 (330)	15.55 (395)
320	13.78 (350)	1.30 (33)	1.18 (30)	7.87 (200)	15.75 (400)	18.70 (475)

Foot mounting – ISO 6431 and VDMA 24562 Part 2

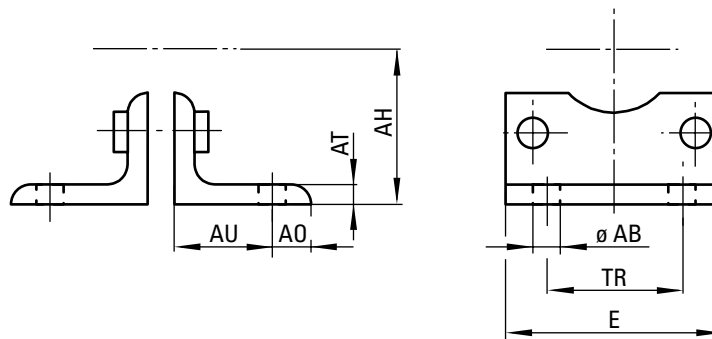

BORE	AB	AH	AO	AT	AU	E	TR
32	.28 (7)	1.26 (32)	.31 (8) [11]	.16 (4)	.94 (24)	1.89 (48)	1.26 (32)
40	.35 (9)	1.42 (36)	.35 (9) [12]	.16 (4) [5]	1.1 (28)	2.09 (53)	1.42 (36)
50	.35 (9)	1.77 (45)	.39 (10) [13]	.2 (5)	1.26 (32)	2.52 (64)	1.77 (45)
63	.35 (9)	1.97 (50)	.47 (12) [13]	.2 (5)	1.26 (32)	2.91 (74)	1.97 (50)
80	.47 (12)	2.48 (63)	.75 (19)	.2 (5) [6]	1.61 (41)	3.86 (98)	2.48 (63)
100	.55 (14)	2.8 (71)	.75 (19)	.2 (5) [6]	1.61 (41)	4.53 (115)	2.95 (75)
125	.63 (16)	3.54 (90)	.79 (20) [25]	.35 (9) [7]	1.77 (45)	5.51 (140)	3.54 (90)
160	.71 (18)	4.53 (115)	.79 (20)	.31 (8)	2.36 (60)	7.09 (180)	4.53 (115)
200	.87 (22)	5.31 (135)	1.18 (30)	.35 (9)	2.76 (70)	8.66 (220)	5.31 (135)
250	1.02 (26)	6.5 (165)	1.38 (35)	.39 (10)	2.95 (75)	11.02 (280)	6.5 (165)
320	1.30 (33)	7.87 (200)	1.77 (45)	.63 (16)	3.25 (85)	13.78 (350)	7.87 (200)

Dimensions in inches (mm)

Series ML Cylinder Accessories

Rear Clevis Mount – Type 1 ISO 6431 and VDMA 24562

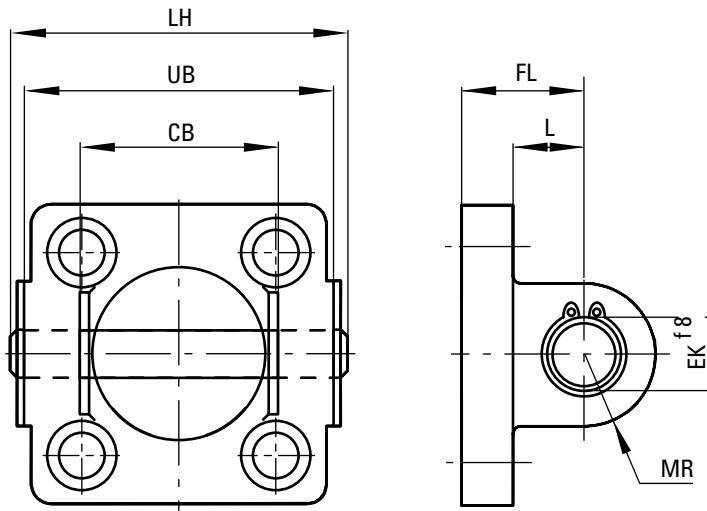

BORE	CB	EK	FL	L	LH	MR	UB
32	1.02 (26)	.39 (10)	.87 (22)	.51 (13)	2.05 (52)	.35 (9)	1.77 (45)
40	1.10 (28)	.47 (12)	.98 (25)	.63 (16)	2.36 (60)	.47 (12)	2.05 (52)
50	1.26 (32)	.47 (12)	1.06 (27)	.67 (17)	2.68 (68)	.47 (12)	2.36 (60)
63	1.57 (40)	.63 (16)	1.26 (32)	.87 (22)	3.12 (79)	.59 (15)	2.76 (70)
80	1.97 (50)	.63 (16)	1.42 (36)	.87 (22)	3.9 (99)	.59 (15)	3.54 (90)
100	2.36 (60)	.79 (20)	1.61 (41)	1.06 (27)	4.69 (119)	.79 (20)	4.31 (110)
125	2.76 (70)	.98 (25)	1.97 (50)	1.22 (31)	*5.47 (139)	.98 (25)	5.12 (130)
160	3.54 (90)	1.18 (30)	2.17 (55)	1.4 (35.5)	7.13 (181)	1.18 (30)	6.69 (170)
200	3.54 (90)	1.18 (30)	2.36 (60)	1.42 (36)	7.13 (181)	1.18 (30)	6.69 (170)
250	4.31 (110)	1.57 (40)	2.76 (70)	1.77 (45)	8.58 (218)	1.57 (40)	7.87 (200)
320	4.72 (120)	1.77 (45)	3.15 (80)	1.97 (50)	9.37 (238)	1.77 (45)	8.66 (220)

Dimensions in inches (mm)

Rear Clevis Mount – Type 2 VDMA 24562

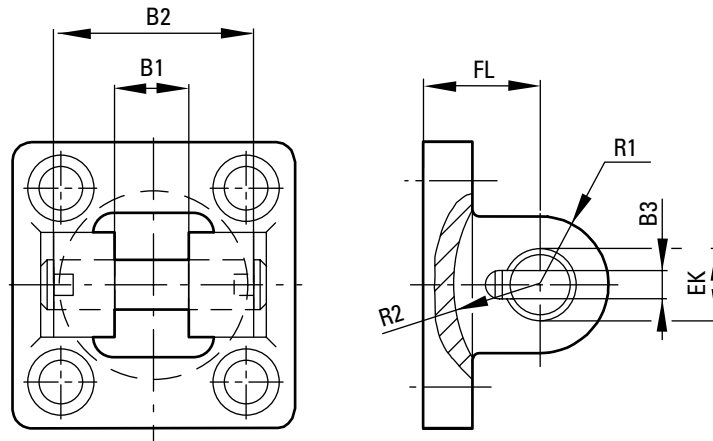

BORE	B1	B2	B3	EK	FL	R1	R2
32	.55 (14)	1.34 (34)	.14 (3.3)	.39 (10)	.87 (22)	.43 (11)	.67 (17)
40	.63 (16)	1.57 (40)	.18 (4.3)	.47 (12)	.98 (25)	.47 (12)	.79 (20)
50	.83 (21)	1.77 (45)	.18 (4.3)	.63 (16)	1.06 (27)	.57 (14.5)	.87 (22)
63	.83 (21)	2.01 (51)	.18 (4.3)	.63 (16)	1.26 (32)	.71 (18)	.98 (25)
80	.98 (25)	2.56 (65)	.18 (4.3)	.79 (20)	1.42 (36)	.87 (22)	1.18 (30)
100	.98 (25)	2.95 (75)	.26 (6.3)	.79 (20)	1.61 (41)	.87 (22)	1.26 (32)
125	1.46 (37)	3.82 (97)	.26 (6.3)	1.18 (30)	1.97 (50)	1.18 (30)	1.65 (42)
160	1.69 (43)	4.8 (122)	.26 (6.3)	1.38 (35)	2.17 (55)	1.42 (36)	1.81 (46)
200	1.69 (43)	4.8 (122)	.26 (6.3)	1.38 (35)	2.36 (60)	1.5 (38)	1.93 (49)

Dimensions in inches (mm)

Series ML Cylinder Accessories

Piston rod clevis mounting ISO 8140

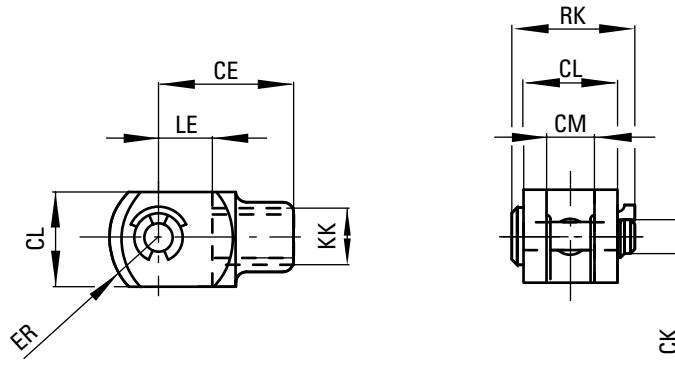

BORE	CE	CK	CL	CM	ER	KK	LE	RK
32	1.57 (40)	0.39 (10)	0.79 (20)	0.39 (10)	0.63 (16)	M10x1.25	0.79 (20)	1.10 (28)
40	1.89 (48)	0.47 (12)	0.94 (24)	0.47 (12)	0.75 (19)	M12x1.25	0.94 (24)	1.26 (32)
50	2.52 (64)	0.63 (16)	1.26 (32)	0.63 (16)	0.98 (25)	M16x1.5	1.26 (32)	1.63 (41.5)
63	2.52 (64)	0.63 (16)	1.26 (32)	0.63 (16)	0.98 (25)	M16x1.5	1.26 (32)	1.63 (41.5)
80	3.15 (80)	0.79 (20)	1.57 (40)	0.79 (20)	1.26 (32)	M20x1.5	1.57 (40)	1.97 (50)
100	3.15 (80)	0.79 (20)	1.57 (40)	0.79 (20)	1.26 (32)	M20x1.5	1.57 (40)	1.97 (50)
125	4.33 (110)	1.18 (30)	2.17 (55)	1.18 (30)	1.77 (45)	M27x2	2.13 (54)	2.44 (62)
160	5.67 (144)	1.38 (35)	2.76 (70)	1.38 (35)	2.24 (57)	M36x2	2.83 (72)	3.74 (95)
200	5.67 (144)	1.38 (35)	2.76 (70)	1.38 (35)	2.24 (57)	M36x2	2.83 (72)	3.74 (95)
250	6.61 (168)	1.57 (40)	3.35 (85)	1.57 (40)	2.68 (68)	M42x2	3.31 (84)	4.17 (106)
320	7.56 (192)	1.97 (50)	3.78 (96)	1.97 (50)	3.35 (85)	M48x2	3.78 (96)	4.76 (121)

Dimensions in inches (mm)

Front or rear detachable trunnion mounting VDMA 24562 Part 2

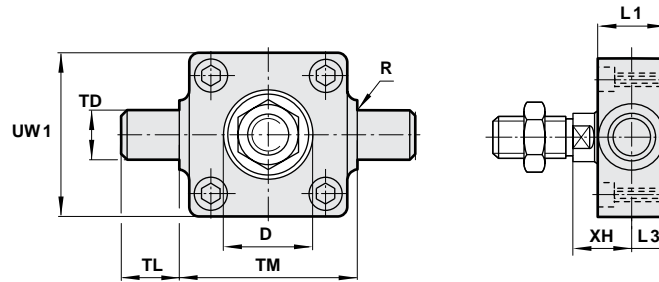

BORE	D	L1	L3	R	TD	TL	TM	UW	XH
32	1.18 (30)	0.63 (16)	0.31 (8)	0.04 (1)	0.47 (12)	0.47 (12)	1.97 (50)	1.97 (50)	0.71 (18)
40	1.38 (35)	0.79 (20)	0.39 (10)	0.06 (1.6)	0.63 (16)	0.63 (16)	2.48 (63)	2.17 (55)	0.79 (20)
50	1.57 (40)	0.94 (24)	0.47 (12)	0.06 (1.6)	0.63 (16)	0.63 (16)	2.95 (75)	2.56 (65)	0.98 (25)
63	1.77 (45)	0.94 (24)	0.47 (12)	0.06 (1.6)	0.79 (20)	0.79 (20)	3.54 (90)	2.95 (75)	0.98 (25)
80	1.77 (45)	1.10 (28)	0.55 (14)	0.06 (1.6)	0.79 (20)	0.79 (20)	4.33 (110)	3.94 (100)	1.26 (32)
100	2.17 (55)	1.50 (38)	0.75 (19)	0.08 (2)	0.98 (25)	0.98 (25)	5.20 (132)	4.72 (120)	1.26 (32)
125	2.36 (60)	1.97 (50)	0.98 (25)	0.08 (2)	0.98 (25)	0.98 (25)	6.30 (160)	5.71 (145)	1.57 (40)
160	—	—	—	0.10 (2.5)	1.26 (32)	1.26 (32)	7.87 (200)	—	—
200	—	—	—	0.10 (2.5)	1.26 (32)	1.26 (32)	9.84 (250)	—	—
250	—	—	—	0.13 (3.2)	1.57 (40)	1.57 (40)	12.60 (320)	—	—
320	—	—	—	0.13 (3.2)	1.97 (50)	1.97 (50)	15.75 (400)	—	—

Dimensions in inches (mm)

Series ML Cylinder Accessories

Front hinge mounting

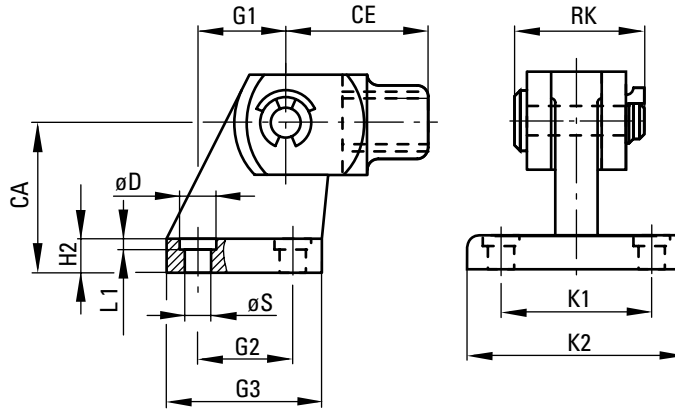

BORE	CA	CE	D	G1	G2	G3	H2	K1	K2	L1	RK	S
32	1.26 (32)	1.57 (40)	0.43 (11)	0.83 (21)	0.71 (18)	1.22 (31)	0.31 (8)	1.50 (38)	2.01 (51)	0.06 (1.6)	1.10 (28)	0.26 (6.6)
40	1.42 (36)	1.89 (48)	0.43 (11)	0.94 (24)	0.87 (22)	1.38 (35)	0.39 (10)	1.61 (41)	2.13 (54)	0.06 (1.6)	1.26 (32)	0.26 (6.6)
50	1.77 (45)	2.52 (64)	0.59 (15)	1.30 (33)	1.18 (30)	1.77 (45)	0.47 (12)	1.97 (50)	2.56 (65)	0.06 (1.6)	1.63 (41.5)	0.35 (9)
63	1.97 (50)	2.52 (64)	0.59 (15)	1.46 (37)	1.38 (35)	1.97 (50)	0.47 (12)	2.05 (52)	2.64 (67)	0.06 (1.6)	1.63 (41.5)	0.35 (9)
80	2.48 (63)	3.15 (80)	0.71 (18)	1.85 (47)	1.57 (40)	2.36 (60)	0.55 (14)	2.60 (66)	3.39 (86)	0.10 (2.5)	1.97 (50)	0.43 (11)
100	2.80 (71)	3.15 (80)	0.71 (18)	2.17 (55)	1.97 (50)	2.76 (70)	0.59 (15)	2.99 (76)	3.78 (96)	0.10 (2.5)	1.97 (50)	0.43 (11)
125	3.54 (90)	4.33 (110)	0.79 (20)	2.76 (70)	2.36 (60)	3.54 (90)	0.79 (20)	3.70 (94)	4.88 (124)	0.13 (3.2)	2.44 (62)	0.55 (14)
160	4.53 (115)	5.67 (144)	0.79 (20)	3.82 (97)	3.46 (88)	4.96 (126)	0.98 (25)	4.65 (118)	6.14 (156)	0.16 (4)	3.74 (95)	0.55 (14)
200	5.31 (135)	5.67 (144)	0.94 (24)	4.13 (105)	3.54 (90)	5.12 (130)	1.18 (30)	4.80 (122)	6.38 (162)	0.16 (4)	3.74 (95)	0.71 (18)
250	—	6.61 (168)	—	—	—	—	—	—	—	—	4.17 (106)	—
320	—	7.56 (192)	—	—	—	—	—	—	—	—	4.76 (121)	—

Dimensions in inches (mm)

Rear eye mounting – ISO 6431 and VDMA 24562 Part 2

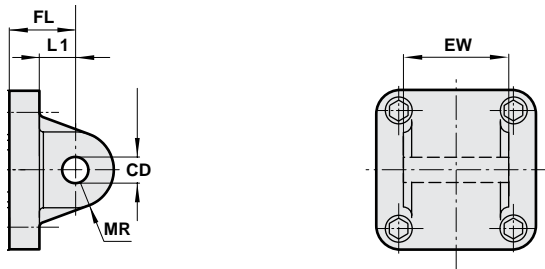

BORE	CD	EW	FL	L1	MR
32	0.39 (10)	1.02 (25.8)	0.87 (22)	0.51 (13)	0.35 (9)
40	0.47 (12)	1.09 (27.8)	0.98 (25)	0.63 (16)	0.47 (12)
50	0.47 (12)	1.25 (31.7)	1.06 (27)	0.67 (17)	0.47 (12)
63	0.63 (16)	1.56 (39.7)	1.26 (32)	0.87 (22)	0.59 (15)
80	0.63 (16)	1.96 (49.7)	1.42 (36)	0.87 (22)	0.59 (15)
100	0.79 (20)	2.35 (59.7)	1.61 (41)	1.06 (27)	0.79 (20)
125	0.98 (25)	2.74 (69.7)	1.97 (50)	1.30 (33)	0.98 (25)
160	1.18 (30)	3.53 (89.7)	2.17 (55)	1.40 (35.5)	1.18 (30)
200	1.18 (30)	3.53 (89.7)	2.36 (60)	1.46 (37)	1.18 (30)

Dimensions in inches (mm)

Series ML Cylinder Accessories

Rear Hinge Mount – Type 1
VDMA 24562 Part 2

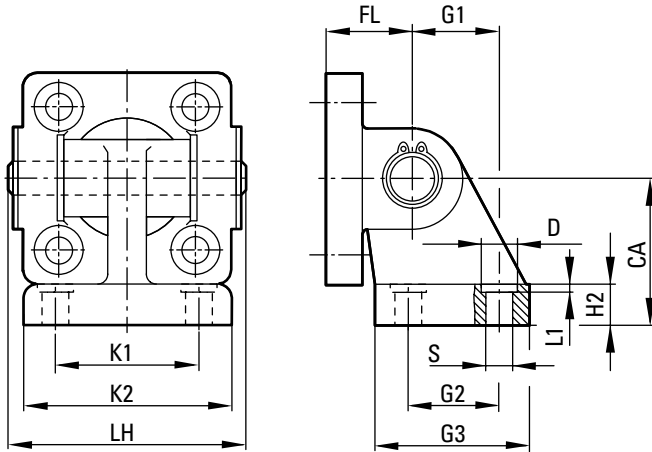

Rear Hinge Mount – Type 2
VDMA 24562 Part 2

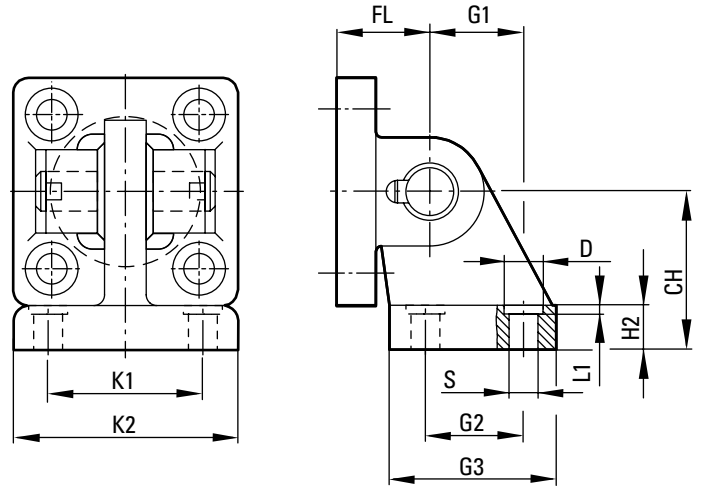

BORE	CA	CH	D	FL	G1	G2	G3	H2	K1	K2	L1	LH	S
32	1.26 (32)	1.26 (32)	.43 (11)	.87 (22)	.83 (21)	.71 (18)	1.22 (31)	.31 (8)	1.5 (38)	2.01 (51)	.06 (1.6)	2.05 (52)	.26 (6.6)
40	1.42 (36)	1.42 (36)	.43 (11)	.98 (25)	.94 (24)	.87 (22)	1.38 (35)	.39 (10)	1.61 (41)	2.13 (54)	.06 (1.6)	2.36 (60)	.26 (6.6)
50	1.77 (45)	1.77 (45)	.59 (15)	1.06 (27)	1.3 (33)	1.18 (30)	1.77 (45)	.47 (12)	1.97 (50)	2.56 (65)	.06 (1.6)	2.68 (68)	.35 (9)
63	1.97 (50)	1.97 (50)	.59 (15)	1.26 (32)	1.46 (37)	1.38 (35)	1.97 (50)	.47 (12)	2.05 (52)	2.64 (67)	.06 (1.6)	3.11 (79)	.35 (9)
80	2.48 (63)	2.48 (63)	.71 (18)	1.42 (36)	1.85 (47)	1.57 (40)	2.36 (60)	.55 (14)	2.6 (66)	3.39 (86)	.1 (2.5)	3.9 (99)	.43 (11)1
100	2.8 (71)	2.8 (71)	.71 (18)	1.61 (41)	2.17 (55)	1.97 (50)	2.76 (70)	.59 (15)	2.99 (76)	3.78 (96)	.1 (2.5)	4.69 (119)	.43 (11)
125	3.54 (90)	3.54 (90)	.79 (20)	1.97 (50)	2.76 (70)	2.36 (60)	3.54 (90)	.79 (20)	3.7 (94)	4.88 (124)	.12 (3.2)	5.47 (139)	.55 (14)
160	4.53 (115)	4.53 (115)	.79 (20)	2.17 (55)	3.82 (97)	3.46 (88)	4.96 (126)	.98 (25)	4.65 (118)	6.14 (156)	.16 (4)	7.13 (181)	.55 (14)
200	5.31 (135)	5.31 (135)	.94 (24)	2.36 (60)	4.13 (105)	3.54 (90)	5.12 (130)	1.18 (30)	4.8 (122)	6.38 (162)	.16 (4)	7.13 (181)	.71 (18)
250*	6.50 (165)	–	1.3 (3)3	2.76 (70)	5.04 (128)	4.33 (110)	6.3 (160)	1.38 (35)	5.91 (150)	7.87 (200)	.08 (2)	8.58 (218)	.87 (22)
320*	7.87 (200)	–	1.57 (40)	3.15 (80)	5.91 (150)	4.8 (122)	7.31 (186)	1.57 (40)	6.69 (170)	9.21 (234)	.08 (2)	9.37 (238)	1.02 (26)

Dimensions in inches (mm)

**Trunnion support
mounting
(Swivel bearing)**

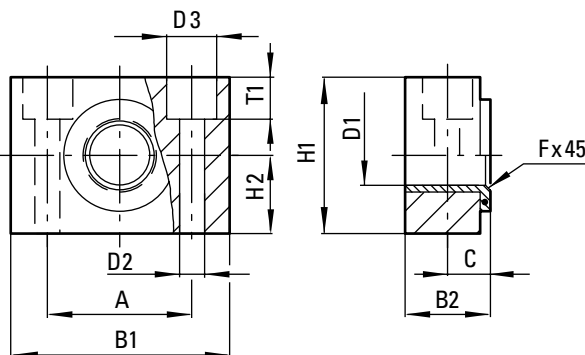

BORE	A	B1	B2	C	D2	D3	FX45°	H1	H2	T1
32	1.26 (32)	1.81 (46)	.71 (18)	.41 (10.5)	.26 (6.6)	.43 (11)	.04 (1)	1.18 (30)	.59 (15)	.27 (6.8)
40	1.42 (36)	2.17 (55)	.83 (21)	.47 (12)	.35 (9)	.59 (15)	.06 (1.6)	1.42 (36)	.71 (18)	.35 (9)
50	1.42 (36)	2.17 (55)	.83 (21)	.47 (12)	.35 (9)	.59 (15)	.06 (1.6)	1.42 (36)	.71 (18)	.35 (9)
63	1.65 (42)	2.56 (65)	.91 (23)	.51 (13)	.43 (11)	.71 (18)	.06 (1.6)	1.57 (40)	.79 (20)	.43 (11)
80	1.65 (42)	2.56 (65)	.91 (23)	.51 (13)	.43 (11)	.71 (18)	.06 (1.6)	1.57 (40)	.79 (20)	.43 (11)
100	1.97 (50)	2.95 (75)	1.12 (28.5)	.63 (16)	.55 (14)	.79 (20)	.08 (2)	1.97 (50)	.98 (25)	.51 (13)
125	1.97 (50)	2.95 (75)	1.12 (28.5)	.63 (16)	.55 (14)	.79 (20)	.08 (2)	1.97 (50)	.98 (25)	.51 (13)
160	2.36 (60)	3.62 (92)	1.54 (39)	.85 (21.5)	.71 (18)	1.02 (26)	.10 (2.5)	2.36 (60)	.98 (25)	.61 (15.5)
200	2.36 (60)	3.62 (92)	1.54 (39)	.85 (21.5)	.71 (18)	1.02 (26)	.10 (2.5)	2.36 (60)	.98 (25)	.61 (15.5)

Dimensions in inches (mm)

Series ML Cylinder Accessories

Center trunnion
mounting –
(for tie rod types)

ISO 6431 and VDMA
24562 Part 2

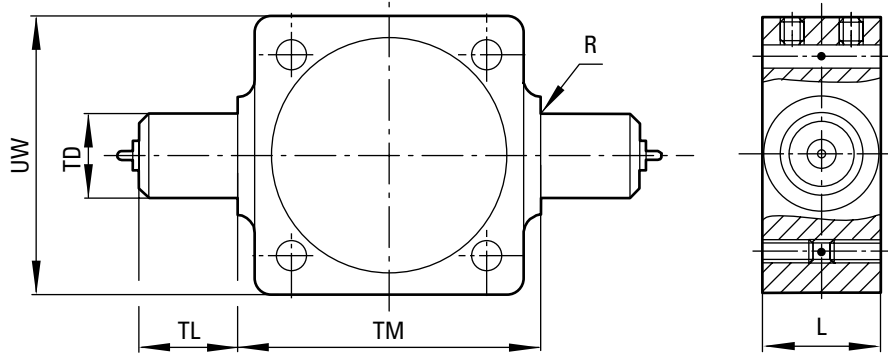

BORE	L	R	TD	TL	TM	UW	TORQUE IN. LB.
32	.79 (20)	.04 (1)	.47 (12)	.47 (12)	1.97 (50)	1.97 (50)	53.1
40	.94 (24)	.06 (1.6)	.63 (16)	.63 (16)	2.48 (63)	2.28 (58)	53.1
50	1.10 (28)	.06 (1.6)	.63 (16)	.63 (16)	2.95 (75)	2.76 (70)	53.1
63	1.10 (28)	.06 (1.6)	.79 (20)	.79 (20)	3.54 (90)	3.15 (80)	88.5
80	1.10 (28)	.06 (1.6)	.79 (20)	.79 (20)	4.33 (110)	3.94 (100)	88.5
100	1.50 (38)	.08 (2)	.98 (25)	.98 (25)	5.20 (132)	4.96 (126)	132.75
125	1.97 (50)	.08 (2)	.98 (25)	.98 (25)	6.30 (160)	5.99 (152)	221.25
160	1.97 (50)	.10 (2.5)	1.26 (32)	1.26 (32)	7.87 (200)	7.56 (192)	354
200	1.97 (50)	.10 (2.5)	1.26 (32)	1.26 (32)	9.84 (250)	9.45 (240)	354
250	2.36 (60)	.12 (3.2)	1.57 (40)	1.57 (40)	12.60 (320)	12.52 (318)	–
320	2.76 (70)	.12 (3.2)	1.97 (50)	1.97 (50)	15.75 (400)	15.75 (400)	–

Dimensions in inches (mm)

Series ML Cylinder Accessories

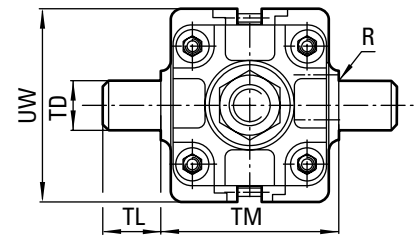
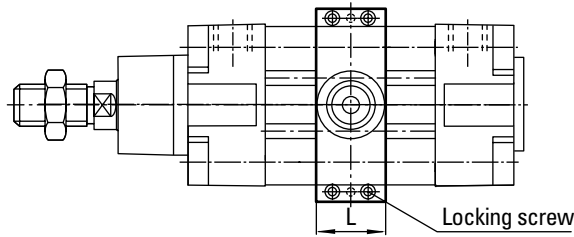

Adjustable center trunnion mounting – (for profile types) ISO 6431, VDMA 24562 Part 2

BORE	L	R	TD	TL	TM	UW	TORQUE IN. LB.
32	.79 (20)	.04 (1)	.47 (12)	.47 (12)	1.97 (50)	1.97 (50)	53.1
40	.94 (24)	.06 (1.6)	.63 (16)	.63 (16)	2.48 (63)	2.28 (58)	53.1
50	1.10 (28)	.06 (1.6)	.63 (16)	.63 (16)	2.95 (75)	2.76 (70)	53.1
63	1.10 (28)	.06 (1.6)	.79 (20)	.79 (20)	3.54 (90)	3.15 (80)	88.5
80	1.10 (28)	.06 (1.6)	.79 (20)	.79 (20)	4.33 (110)	3.94 (100)	88.5
100	1.50 (38)	.08 (2)	.98 (25)	.98 (25)	5.20 (132)	4.96 (126)	132.75
125	1.97 (50)	.08 (2)	.98 (25)	.98 (25)	6.30 (160)	5.99 (152)	221.25
160	1.97 (50)	.10 (2.5)	1.26 (32)	1.26 (32)	7.87 (200)	7.56 (192)	354
200	1.97 (50)	.10 (2.5)	1.26 (32)	1.26 (32)	9.84 (250)	9.45 (240)	354
250	2.36 (60)	.12 (3.2)	1.57 (40)	1.57 (40)	12.60 (320)	12.52 (318)	–
320	2.76 (70)	.12 (3.2)	1.97 (50)	1.97 (50)	15.75 (400)	15.75 (400)	–

Narrow hinge mounting

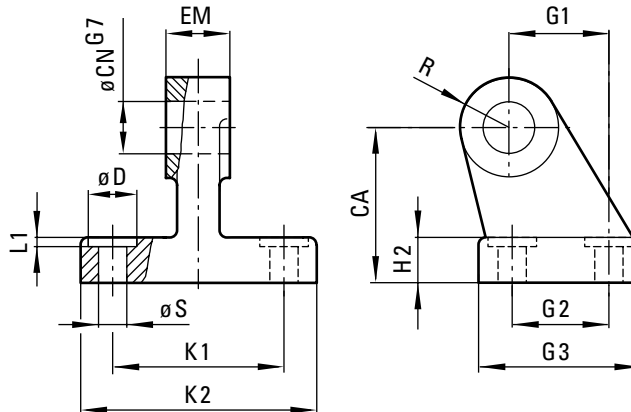

BORE	CA	CK	D	EM	G1	G2	G3	H2	K1	K2	S
32	1.26 (32)	0.39 (10)	0.43 (11)	1.02 (26)	0.83 (21)	0.71 (18)	1.22 (31)	0.31 (8)	1.50 (38)	2.01 (51)	0.26 (6.6)
40	1.42 (36)	0.47 (12)	0.43 (11)	1.10 (28)	0.94 (24)	0.87 (22)	1.38 (35)	0.39 (10)	1.61 (41)	2.13 (54)	0.26 (6.6)
50	1.77 (45)	0.47 (12)	0.59 (15)	1.26 (32)	1.30 (33)	1.18 (30)	1.77 (45)	0.47 (12)	1.97 (50)	2.56 (65)	0.35 (9)
63	1.97 (50)	0.63 (16)	0.59 (15)	1.57 (40)	1.46 (37)	1.38 (35)	1.97 (50)	0.47 (12)	2.05 (52)	2.64 (67)	0.35 (9)
80	2.48 (63)	0.63 (16)	0.71 (18)	1.97 (50)	1.85 (47)	1.57 (40)	2.36 (60)	0.55 (14)	2.60 (66)	3.39 (86)	0.43 (11)
100	2.80 (71)	0.79 (20)	0.71 (18)	2.36 (60)	2.17 (55)	1.97 (50)	2.76 (70)	0.59 (15)	3.00 (76)	3.78 (96)	0.43 (11)
125	3.54 (90)	0.98 (25)	0.79 (20)	2.76 (70)	2.76 (70)	2.36 (60)	3.54 (90)	0.79 (20)	3.70 (94)	4.88 (124)	0.55 (14)
160	4.53 (115)	1.18 (30)	0.79 (20)	3.54 (90)	3.82 (97)	3.46 (88)	4.96 (126)	0.98 (25)	4.65 (118)	6.14 (156)	0.55 (14)
200	5.31 (135)	1.18 (30)	0.94 (24)	3.54 (90)	4.13 (105)	3.54 (90)	5.12 (130)	1.18 (30)	4.80 (122)	6.38 (162)	0.71 (18)
250	6.50 (165)	1.57 (40)	1.30 (33)	4.33 (110)	5.04 (128)	4.33 (110)	6.30 (160)	1.38 (35)	5.91 (150)	7.87 (200)	0.87 (22)
320	7.87 (200)	1.77 (45)	1.57 (40)	4.72 (120)	5.91 (150)	4.80 (122)	7.32 (186)	1.57 (40)	6.69 (170)	9.21 (234)	1.02 (26)

Series ML Cylinder Accessories

Wide hinge mounting VDMA 24562 Part 2

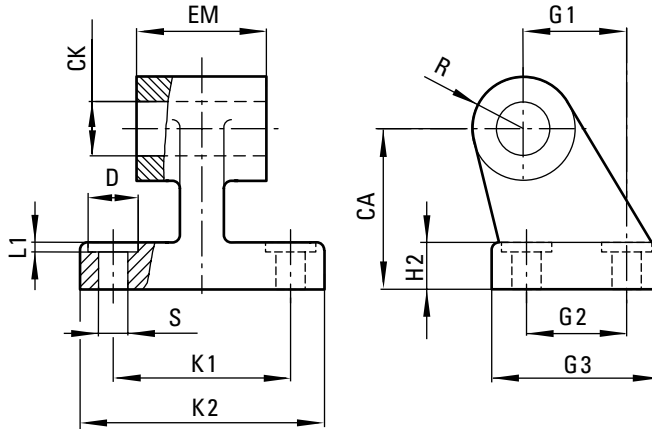

BORE	CA	CK	EM	G1	G2	G3	H2	K1	K2	L1	R	S
32	1.26 (32)	0.39 (10)	1.02 (26)	0.83 (21)	0.71 (18)	1.22 (31)	0.31 (8)	1.50 (38)	2.01 (51)	0.06 (1.6)	0.39 (10)	0.26 (6.6)
40	1.42 (36)	0.47 (12)	1.10 (28)	0.94 (24)	0.87 (22)	1.38 (35)	0.39 (10)	1.61 (41)	2.13 (54)	0.06 (1.6)	0.43 (11)	0.26 (6.6)
50	1.77 (45)	0.47 (12)	1.26 (32)	1.30 (33)	1.18 (30)	1.77 (45)	0.47 (12)	1.97 (50)	2.56 (65)	0.06 (1.6)	0.51 (13)	0.35 (9)
63	1.97 (50)	0.63 (16)	1.57 (40)	1.46 (37)	1.38 (35)	1.97 (50)	0.47 (12)	2.05 (52)	2.64 (67)	0.06 (1.6)	0.59 (15)	0.35 (9)
80	2.48 (63)	0.63 (16)	1.97 (50)	1.85 (47)	1.57 (40)	2.36 (60)	0.55 (14)	2.60 (66)	3.39 (86)	0.10 (2.5)	0.59 (15)	0.43 (11)
100	2.80 (71)	0.79 (20)	2.36 (60)	2.17 (55)	1.97 (50)	2.76 (70)	0.59 (15)	3.00 (76)	3.78 (96)	0.10 (2.5)	0.75 (19)	0.43 (11)
125	3.54 (90)	0.98 (25)	2.76 (70)	2.76 (70)	2.36 (60)	3.54 (90)	0.79 (20)	3.70 (94)	4.88 (124)	0.13 (3.2)	0.87 (22)	0.55 (14)
160	4.53 (115)	1.18 (30)	3.54 (90)	3.82 (97)	3.46 (88)	4.96 (126)	0.98 (25)	4.65 (118)	6.14 (156)	0.16 (4)	1.22 (31)	0.55 (14)
200	5.31 (135)	1.18 (30)	3.54 (90)	4.13 (105)	3.54 (90)	5.12 (130)	1.18 (30)	4.80 (122)	6.38 (162)	0.16 (4)	1.22 (31)	0.71 (18)
250	6.50 (165)	1.57 (40)	4.33 (110)	5.04 (128)	4.33 (110)	6.30 (160)	1.38 (35)	5.91 (150)	7.87 (200)	0.08 (2)	1.57 (40)	0.87 (22)
320	7.87 (200)	1.77 (45)	4.72 (120)	5.91 (150)	4.80 (122)	7.32 (186)	1.57 (40)	6.69 (170)	9.21 (234)	0.08 (2)	1.77 (45)	1.02 (26)

Swivel hinge mounting VDMA 24562 Part 2

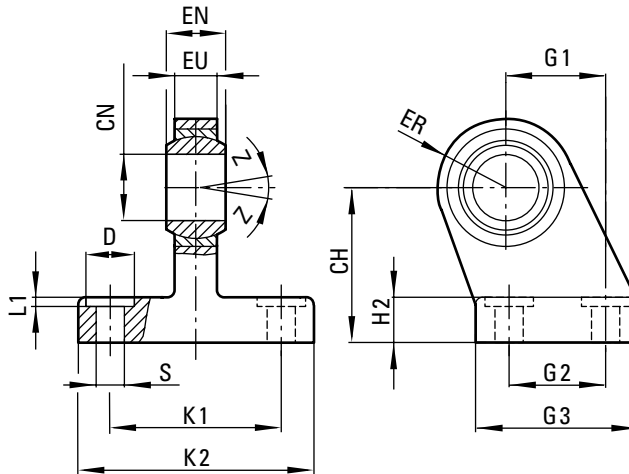

BORE	CH	CN	D	EN	ER	EU	G1	G2	G3	H2	K1	K2	L1	S
32	1.26 (32)	0.39 (10)	0.43 (11)	0.55 (14)	0.63 (16)	0.41 (10.5)	0.83 (21)	0.71 (18)	1.22 (31)	0.31 (8)	1.50 (38)	2.01 (51)	0.06 (1.6)	0.26 (6.6)
40	1.42 (36)	0.47 (12)	0.43 (11)	0.63 (16)	0.75 (19)	0.47 (12)	0.94 (24)	0.87 (22)	1.38 (35)	0.39 (10)	1.61 (41)	2.13 (54)	0.06 (1.6)	0.26 (6.6)
50	1.77 (45)	0.63 (16)	0.59 (15)	0.83 (21)	0.83 (21)	0.59 (15)	1.30 (33)	1.18 (30)	1.77 (45)	0.47 (12)	1.97 (50)	2.56 (65)	0.06 (1.6)	0.35 (9)
63	1.97 (50)	0.63 (16)	0.59 (15)	0.83 (21)	0.94 (24)	0.59 (15)	1.46 (37)	1.38 (35)	1.97 (50)	0.47 (12)	2.05 (52)	2.64 (67)	0.06 (1.6)	0.35 (9)
80	2.48 (63)	0.79 (20)	0.71 (18)	0.98 (25)	1.10 (28)	0.71 (18)	1.85 (47)	1.57 (40)	2.36 (60)	0.55 (14)	2.60 (66)	3.39 (86)	0.10 (2.5)	0.43 (11)
100	2.80 (71)	0.79 (20)	0.71 (18)	0.98 (25)	1.18 (30)	0.71 (18)	2.17 (55)	1.97 (50)	2.76 (70)	0.59 (15)	2.99 (76)	3.78 (96)	0.10 (2.5)	0.43 (11)
125	3.54 (90)	1.18 (30)	0.79 (20)	1.46 (37)	1.57 (40)	0.98 (25)	2.76 (70)	2.36 (60)	3.54 (90)	0.79 (20)	3.70 (94)	4.88 (124)	0.13 (3.2)	0.55 (14)
160	4.53 (115)	1.38 (35)	0.79 (20)	1.69 (43)	1.73 (44)	1.10 (28)	3.82 (97)	3.46 (88)	4.96 (126)	0.98 (25)	4.65 (118)	6.14 (156)	0.16 (4)	0.55 (14)
200	5.31 (135)	1.38 (35)	0.94 (24)	1.69 (43)	1.89 (48)	1.10 (28)	4.13 (105)	3.54 (90)	5.12 (130)	1.18 (30)	4.80 (122)	6.38 (162)	0.16 (4)	0.71 (18)

Dimensions in inches (mm)

Series ML Cylinder Accessories

Universal piston rod eye mounting –

DIN ISO 8139

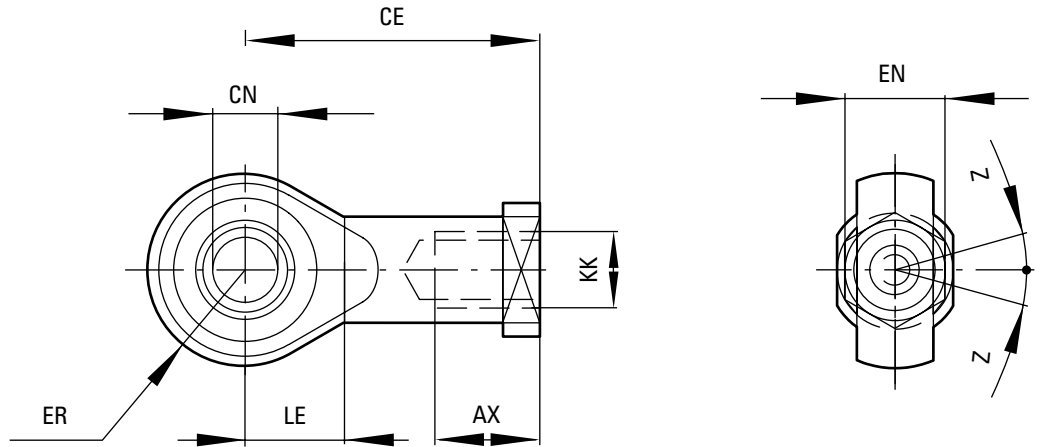

BORE	AX	CE	CN	EN	ER	KK	LE
32	0.79 (20)	1.69 (43)	0.39 (10)	0.55 (14)	0.55 (14)	M 10 x 1.25	0.59 (15)
40	0.87 (22)	1.97 (50)	0.47 (12)	0.63 (16)	0.63 (16)	M 12 x 1.25	0.67 (17)
50	1.10 (28)	2.52 (64)	0.63 (16)	0.83 (21)	0.83 (21)	M 16 x 1.5	0.87 (22)
63	1.10 (28)	2.52 (64)	0.63 (16)	0.83 (21)	0.83 (21)	M 16 x 1.5	0.87 (22)
80	1.30 (33)	3.03 (77)	0.79 (20)	0.98 (25)	0.98 (25)	M 20 x 1.5	1.02 (26)
100	1.30 (33)	3.03 (77)	0.79 (20)	0.98 (25)	0.98 (25)	M 20 x 1.5	1.02 (26)
125	2.01 (51)	4.33 (110)	1.18 (30)	1.46 (37)	1.38 (35)	M 27 x 2	1.42 (36)
160	2.20 (56)	4.92 (125)	1.38 (35)	1.69 (43)	1.57 (40)	M 36 x 2	1.61 (41)
200	2.20 (56)	4.92 (125)	1.38 (35)	1.69 (43)	1.57 (40)	M 36 x 2	1.61 (41)
250	2.36 (60)	5.59 (142)	1.57 (40)	1.93 (49)	1.77 (45)	M 42 x 2	1.81 (46)
320	2.56 (65)	6.30 (160)	1.97 (50)	2.36 (60)	2.28 (58)	M 48 x 2	2.32 (59)

Dimensions in inches (mm)

Series ML Cylinder Accessories

Universal rear eye mounting VDMA 24562 Part 2

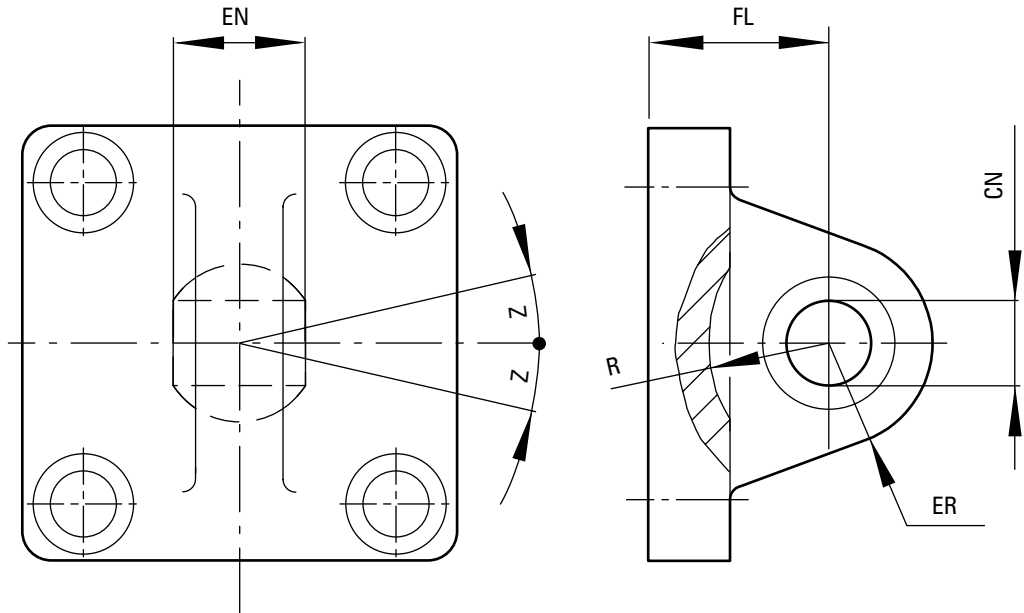

BORE	CN	EN	ER	FL	R	Z	LB
32	.39 (10)	.55 (14)	.63 (16)	.87 (22)	.57 (14.5)	55° (13°)	0.33
40	.47 (12)	.63 (16)	.75 (19)	.98 (25)	.71 (18)	55° (13°)	0.55
50	.63 (16)	.83 (21)	.83 (21)	1.06 (27)	.75 (19)	55° (13°)	0.88
63	.63 (16)	.83 (21)	.94 (24)	1.26 (32)	.94 (24)	59° (15°)	1.21
80	.79 (20)	.98 (25)	1.1 (28)	1.42 (36)	.94 (24)	59° (15°)	1.98
100	.79 (20)	.98 (25)	1.18 (30)	1.61 (41)	1.14 (29)	59° (15°)	3.31
125	1.18 (30)	1.46 (37)	1.57 (40)	1.97 (50)	1.42 (36)	59° (15°)	5.95
160	1.38 (35)	1.69 (43)	1.73 (44)	2.17 (55)	1.61 (41)	61° (16°)	10.14
200	1.38 (35)	1.69 (43)	1.89 (48)	2.36 (60)	1.65 (42)	61° (16°)	16.10

Dimensions in inches (mm)

Series ML Technical Information

Operating Pressure

1 to 16 bar (14.5 to 232 psi)
1 to 10 bar (14.5 to 145 psig)
for ø250 mm and ø320 mm

Operating Temperature

-20°C to +80°C max (-4°F to +176°F max)

[Consult Factory for use below +2°C (35°F)]

Cylinder Diameters

32, 40, 50, 63, 80, 100,
125, 160, 200, 250, 320 mm

Materials for <125mm Bore

Anodized aluminum profile tube

Materials for >125mm Bore

Anodized aluminum tube
Pressure diecast aluminum end covers:

32 to 160 mm (gravity cast aluminum 200 to 320 mm)

Chrome plated stainless steel piston rod

Polyurethane piston rod seals:
32 to 100 mm (nitrile rubber 125 to 320 mm)

Polyurethane piston seals:
32 to 100 mm (nitrile rubber 125 to 320 mm)

Nitrile rubber O-rings

Tie Rod: High strength steel

ML Series Pneumatic Cylinders

Theoretical Forces | Cushioning | Air Consumption

BORE	THEORETICAL FORCES AT 6 BAR (LBS. AT 87 PSI)						AIR CONSUMPTION – LITERS/CM OF STROKE (CUBIC INCHES/INCH)					
	EXTEND LBS. FORCE (NEWTONS)		RETRACT LBS. FORCE (NEWTONS)		CUSHION LENGTH INCH (MM)		INITIAL CUSHION VOLUME INCHES ³ (CM ³)		EXTEND INCH ³ (LITERS)		RETRACT INCH ³ (LITERS)	
32	108	(482)	93	(414)	.75	(19)	.75	(12.3)	8.7	(0.056)	7.5	(0.048)
40	169	(754)	142	(633)	.87	(22)	1.26	(20.7)	13.7	(0.088)	11.5	(0.074)
50	265	(1178)	222	(990)	.94	(24)	2.20	(36)	21.3	(0.137)	17.7	(0.114)
63	420	(1870)	378	(1680)	.94	(24)	3.90	(64)	33.9	(0.218)	30.3	(0.195)
80	678	(3016)	612	(2722)	1.06	(27)	7.08	(116)	54.4	(0.35)	49.8	(0.32)
100	1059	(4710)	993	(4416)	1.34	(34)	14.76	(242)	85.5	(0.55)	79.3	(0.51)
125	1656	(7363)	1547	(6882)	1.61	(41)	27.51	(451)	133.7	(0.86)	122.9	(0.79)
160	2713	(12064)	2543	(11310)	1.77	(45)	49.78	(816)	219.3	(1.41)	205.3	(1.32)
200	4236	(18840)	4068	(18090)	1.77	(45)	80.76	(1324)	342.1	(2.20)	326.6	(2.10)
250	6619	(29436)	6349	(28236)	2.36	(60)	176.9	(2900)	534.0	(3.44)	513.2	(3.30)
320	10846	(48228)	10634	(47292)	2.56	(65)	317.2	(5200)	875.6	(5.63)	841.4	(5.41)

Series RL Features

Ultimate Flexibility

Eaton RL Series rodless pneumatic cylinders provide the ultimate in flexibility. Whether you need to lift, pick, stitch, silk screen, mold, or transport, the Series RL provides limitless possibilities.

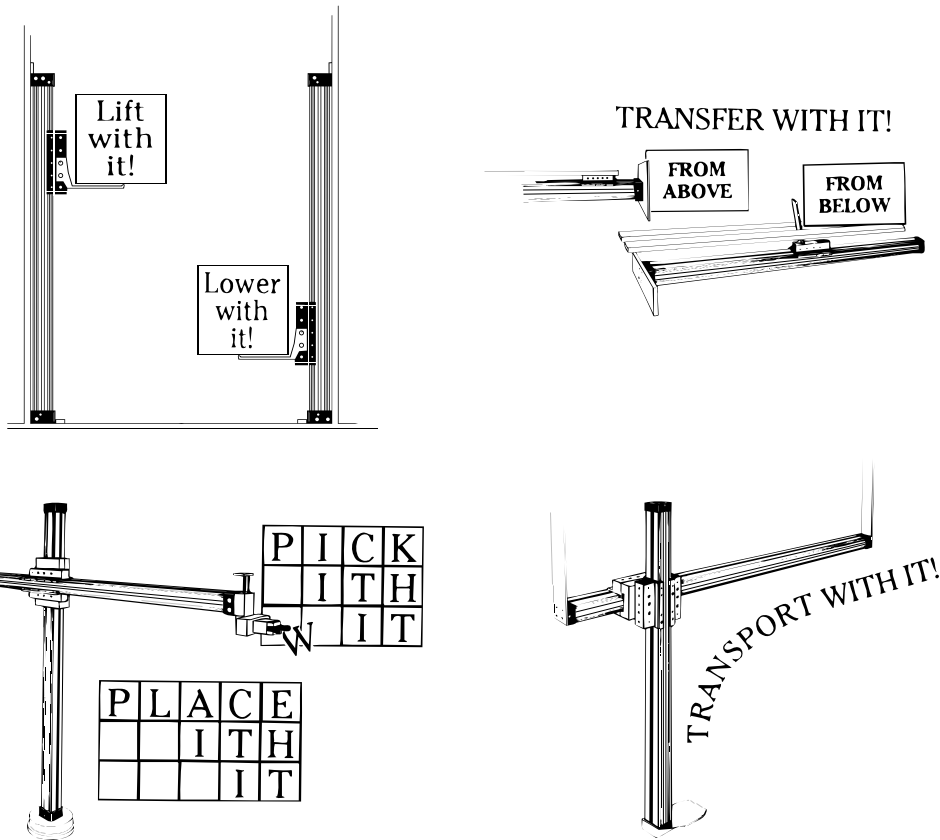

The Extruded Tube of RL Series

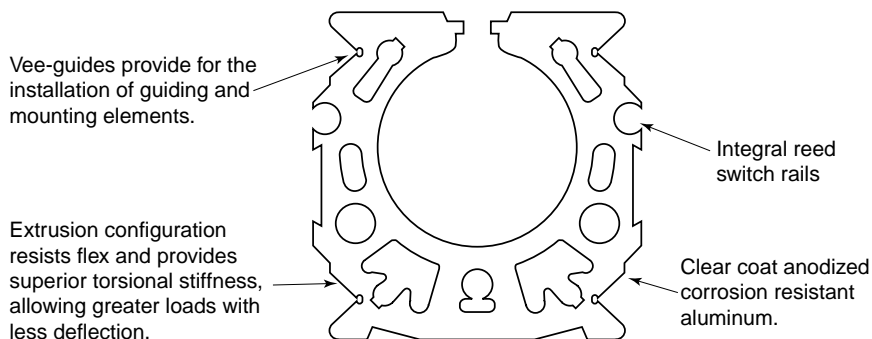

Features:

- Eaton RL rodless cylinders feature a sleek, compact design to provide more flexibility in tight spaces.
- The robust design eliminates the rod (so no buckling possibility) and provides non-rotating load carrying capability without expensive add ons.
- Smoother, consistent performance for precision and high speed applications.

Series RL Model Code

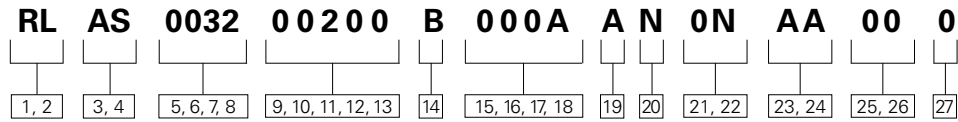

1, 2 Series
RL – Rodless Cylinders

3, 4 Mounting Styles
AS – Side Lug Mount
ES – End Lug Mount
KS – No Mount

5, 6, 7, 8 Bore
 Specify in mm

- 0016 – 16mm
- 0020 – 20mm
- 0025 – 25mm
- 0032 – 32mm
- 0040 – 40mm
- 0050 – 50mm
- 0063 – 63mm
- 0080 – 80mm

9, 10, 11, 12, 13 Stroke
 Specify length in mm

Code	Length
00200	200mm
02250	2250mm

14 Cushion
Code **Location**
B Both Ends

15, 16, 17, 18 Carriage Type

Code **Type**
000A Internally Guided Carriage



000B Externally Guided Carriage



000C Roller Guided Carriage



000D Right Angle Mounting System (with externally guided carriage)



000E Carriage Without Top Cover (with internally guided carriage)



000F Side Mounting Plate (with externally guided carriage)



000G Carriage Mounting Plate (with internally guided carriage)



000H Swinging Bridge Mounting (with internally guided carriage)

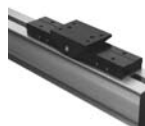

19 Rod End Type
Code **Type**
A Standard

20 Ports
Code **Type**
N Standard NPTF
7 BSPPL

21, 22 Seals
ON – Normal, Standard

23, 24 Port Locations
AA – Standard Option (Multiple Port)

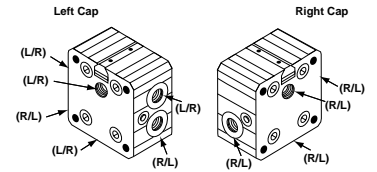

L/R – indicates air
 R/L – indicates air

25, 26 Special Modifications

OP – Magnet Furnished to operate Hall Effect or Reed Type Switch

27 Custom
X – Custom Modification

Series RL

Mounting Style: 16-80 mm Bores

Available Mountings

The variety of standard mountings available in the Series RL gives you a broad selection to match the proper mount to your application. Eaton offers side lug mounts, end lug mounts and no mounts. A guide to proper mount selection is provided on pages 91 through 92. For custom mounts, enter "XX" for model code positions 3 and 4, and give a detailed description with drawings. Series RL cylinders are available in all mounting styles listed.

**Code KS
No Mount**



**Code ES
End Lug**



**Code AS
Side Lug**



Selecting the Proper Mounting

Just as the cylinder bore must be sized to provide the proper force for an application, a cylinder mounting that can absorb these application forces must also be specified. Note: In the mounting information, some mounts have been downrated to minimize deflection. For applications where the motion is linear and parallel to the cylinder rod motion, a rigid mount is recommended. The specifics of each application dictate the correct mounting style.

Series RL Mounting Styles and Installation Dimensions

Code KS – No Mount
(Standard Cylinder)

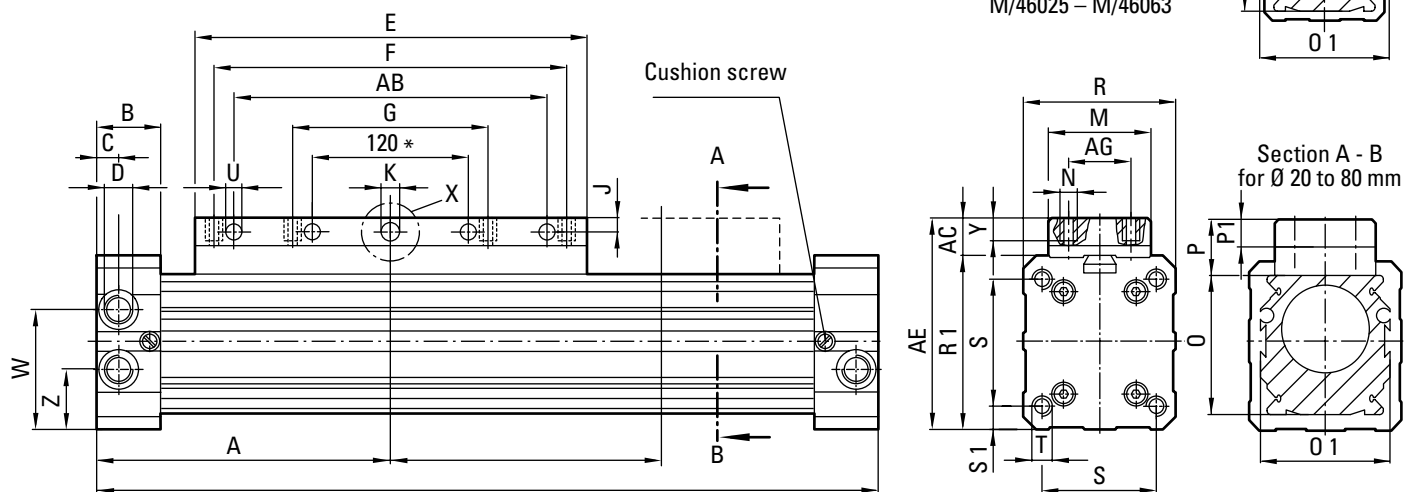

*For cylinder 80 mm

BORE	A	AB	AC	AE	AG	AO	B	C	D	E	F	G	J	K	L
16	2.46 (62.5)	—	0.28 (7)	1.50 (38)	0.31 (8)	/0.30 (7.5)	0.69 (18)	0.31 (08)	— M5	3.15 (80)	2.36 (60)	—	0.10 (2.5)	0.12 (3)	1.22 (31)
20	3.34 (85)	/2.36 (60)	0.55 (14)	2.13/2.32 (54/59)	0.71 (18)	/0.26 (6.5)	0.91 (23)	0.31 (08)	1/8 NPT G1/8	4.33 (110)	3.15 (80)	1.57 (40)	0.14/0.30 (3.5/7.5)	0.17 (4.2)	1.65 (42)
25	3.93 (100)	/2.76 (70)	0.47 (12)	2.36/2.66 (60/67.5)	0.79 (20)	/0.37 (9.5)	0.91 (23)	0.57 (14.5)	1/8 NPT G1/8	5.12 (130)	3.54 (90)	1.77 (45)	/0.20 (5)	0.18 (4.5)	2.05 (52)
32	4.72 (120)	/3.54 (90)	0.63 (16)	3.00/3.23 (76/82)	0.98 (25)	/0.61 (15.5)	1.06 (27)	0.41 (10.5)	1/4 NPT G1/4	6.30 (160)	4.72 (120)	2.36 (60)	/0.20 (5)	0.24 (6)	2.52 (64)
40	5.91 (150)	/4.72 (120)	0.60 (15)	3.54/3.84 (90/97.5)	0.98 (25)	/0.65 (16.5)	1.18 (30)	0.45 (11.5)	1/4 NPT G1/4	8.46 (215)	6.30 (160)	3.15 (80)	/0.20 (5)	0.24 (6)	3.11 (79)
50	7.09 (180)	/6.30 (160)	0.79 (20)	4.33/4.61 (110/117)	0.98 (25)	/0.94 (24)	1.38 (35)	0.55 (14)	3/8 NPT G3/8	9.84 (250)	7.48 (190)	3.74 (95)	/0.26 (6.5)	0.32 (8)	3.62 (92)
63	8.46 (215)	/7.48 (190)	0.79 (20)	4.92/5.39 (125/137)	0.98 (25)	/1.00 (25.5)	1.57 (40)	0.67 (17)	1/2 NPT G1/2	12.60 (320)	9.45 (240)	4.72 (120)	/0.30 (7.5)	0.32 (8)	4.33 (110)
80	10.23 (260)	9.45 (240)	0.94 (24)	6.06/6.50 (154/165)	0.98 (25)	/1.50 (38)	1.77 (45)	0.67 (17)	1/2 NPT G1/2	15.35 (390)	11.81 (300)	5.91 (150)	0.35/0.39 (9/10)	0.47 (12)	5.12 (130)

BORE	M	N	O	O1	P	P1	R	R1	S	S1	T	U	W	Y	Z
16	0.71 (18)	M3	0.98 (25)	1.26 (32)	0.47 (12)	—	1.06 (27)	1.22 (31)	0.63 (16)	0.22 (5.5)	M3x5 deep	—	—	0.16/0.20 (4/5)	0.63 (16.3)
20	1.06/1.06 (27/27)	M5	1.26 (32)	1.50 (38)	0.73 (18.5)	—	1.57 (40)	1.57 (40)	1.26 (32)	0.16 (4)	M5x12 deep	—	—	0.47 (12)	0.85 (21.5)
25	1.26/1.26 (32/32)	M5	1.57 (40)	1.77 (45)	0.63 (16)	0.30 (7.5)	1.89 (48)	1.89 (48)	1.46 (37)	0.22 (5.5)	M5x13 deep	—	1.30 (33)	0.28/0.47 (7/12)	0.67 (17)
32	1.77/1.77 (45/45)	M5	2.05 (52)	2.05 (52)	0.79 (20)	0.39 (10)	2.36 (60)	2.36 (60)	1.85 (47)	0.26 (6.5)	M6x15 deep	—	1.57 (40)	0.31/0.47 (8/12)	0.79 (20)
40	1.77/1.77 (45/45)	M6	2.56 (65)	2.56 (65)	0.79 (20)	0.39 (10)	2.95 (75)	2.95 (75)	2.28 (58)	0.33 (8.5)	M8x20 deep	—	1.97 (50)	0.31/0.47 (8/12)	0.98 (25)
50	1.97/1.97 (50/50)	M8	3.15 (80)	3.15 (80)	0.98 (25)	0.51 (13)	3.54 (90)	3.54 (90)	2.76 (70)	0.39 (10)	M8x25 deep	—	2.36 (60)	0.43/0.67 (11/17)	1.18 (30)
63	1.97/1.97 (50/50)	M8	3.74 (95)	3.74 (95)	0.98 (25)	0.55 (14)	4.13 (105)	4.13 (105)	3.31 (84)	0.41 (10.5)	M10x25 deep	—	2.76 (70)	0.43/0.79 (11/20)	1.38 (35)
80	1.97/1.97 (50/50)	M10	4.72 (120)	4.72 (120)	0.98 (29)	—	5.12 (130)	5.12 (130)	3.94 (100)	0.59 (15)	M12x25 deep	0.43 (11)	3.54 (90)	0.60/0.98 (15/25)	1.57 (40)

Dimensions in inches (mm)

Series RL Mounting Styles and Installation Dimensions

Code ES – End Lug Mounts

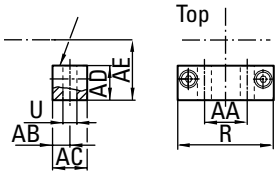

BORE	AA	AB	AC	AD	AE	R	U
16	0.63 (16)	0.39 (10)	0.59 (15)	0.12 (03)	0.63 (16)	1.06 (27)	0.22 (5.5)
20	0.67 (17)	0.20 (05)	0.39 (10)	0.39 (10)	0.85 (21.5)	1.57 (40)	0.22 (5.5)
25	0.71 (18)	0.28 (07)	0.59 (15)	0.53 (13.5)	0.94 (24)	1.89 (48)	0.28 (7)
32	1.02 (26)	0.43 (11)	0.87 (22)	0.65 (16.5)	1.20 (30.5)	2.36 (60)	0.35 (9)
40	1.18 (30)	0.43 (11)	0.87 (22)	0.77 (19.5)	1.48 (37.5)	2.95 (75)	0.35 (9)
50	1.65 (42)	0.47 (12)	0.98 (25)	0.94 (24)	1.77 (45)	3.54 (90)	0.43 (11)
63	1.89 (48)	0.51 (13)	0.98 (25)	1.08 (27.5)	2.13 (54)	4.13 (105)	0.51 (13)
80	2.52 (64)	0.49 (12.5)	0.98 (25)	1.38 (35)	2.76 (70)	5.12 (130)	0.55 (14)

End cover mounts for cylinders 25 to 80mm can be attached to give different distances AE. When used together with a center support mounting the word 'TOP' should be visible on the top face of the mount.

Dimensions in inches (mm)

Code AS – Side Lug Mounts

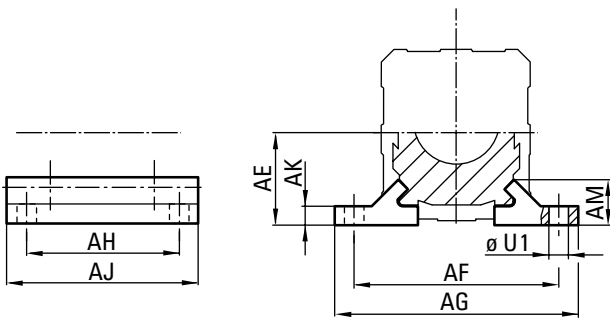

BORE	AE	AF	AG	AH	AJ	AK	AM	U
16	0.63 (16)	1.57 (40)	1.97 (50)	0.79 (20)	1.18 (30)	0.14 (3.5)	0.35 (9)	0.22 (5.5)
20	0.85 (21.5)	2.05 (52)	2.44 (62)	1.77 (45)	2.36 (60)	0.18 (5)	0.47 (12)	0.22 (5.5)
25	0.94 (24)	2.36 (60)	2.83 (72)	2.36 (60)	3.15 (80)	0.22 (5.5)	0.51 (13)	0.26 (6.6)
32	1.20 (30.5)	2.99 (76)	3.62 (92)	2.76 (70)	3.94 (100)	0.26 (6.5)	0.73 (18.5)	0.35 (9)
40	1.48 (37.5)	3.62 (92)	4.25 (108)	3.54 (90)	4.72 (120)	0.30 (7.5)	0.73 (18.5)	0.35 (9)
50	1.77 (45)	4.33 (110)	5.04 (128)	4.33 (110)	5.51 (140)	0.30 (7.5)	0.73 (18.5)	0.43 (11)
63	2.13 (54)	5.20 (132)	6.06 (154)	4.72 (120)	6.30 (160)	0.35 (9)	0.98 (25)	0.51 (13)
80	2.76 (70)	6.10 (155)	7.09 (180)	5.51 (140)	7.09 (180)	0.47 (12)	1.12 (28.5)	0.55 (14)

Dimensions in inches (mm)

Series RL Carriage Options

Code 000A – Cylinder with Internal guide

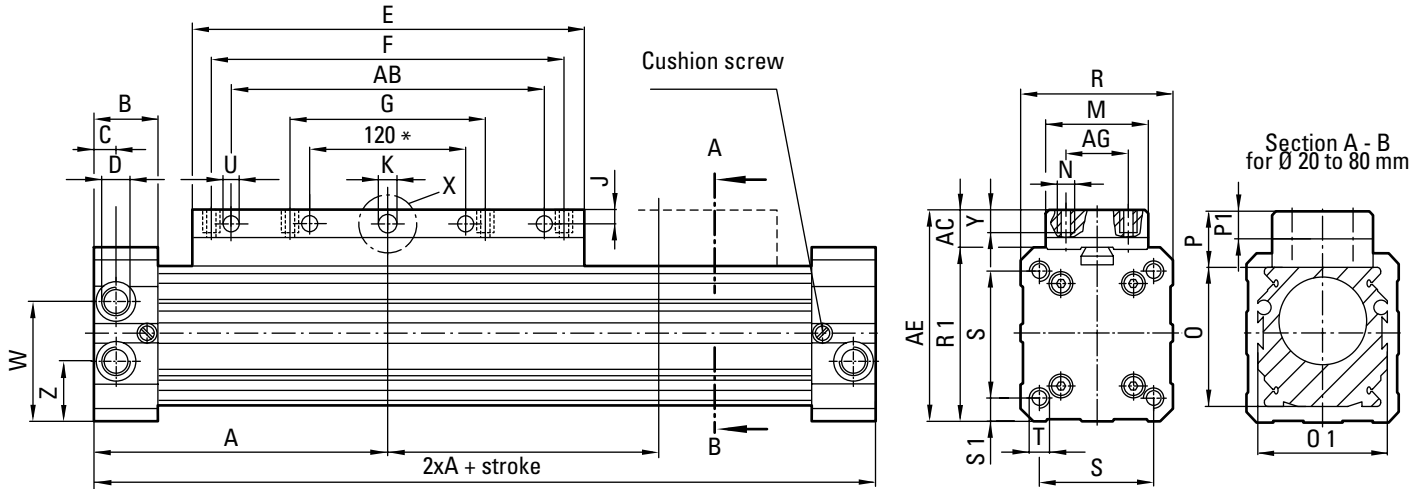

*For cylinder \varnothing 80 mm

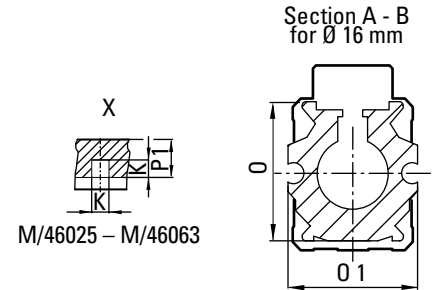

Code 000B – Cylinder with external guide

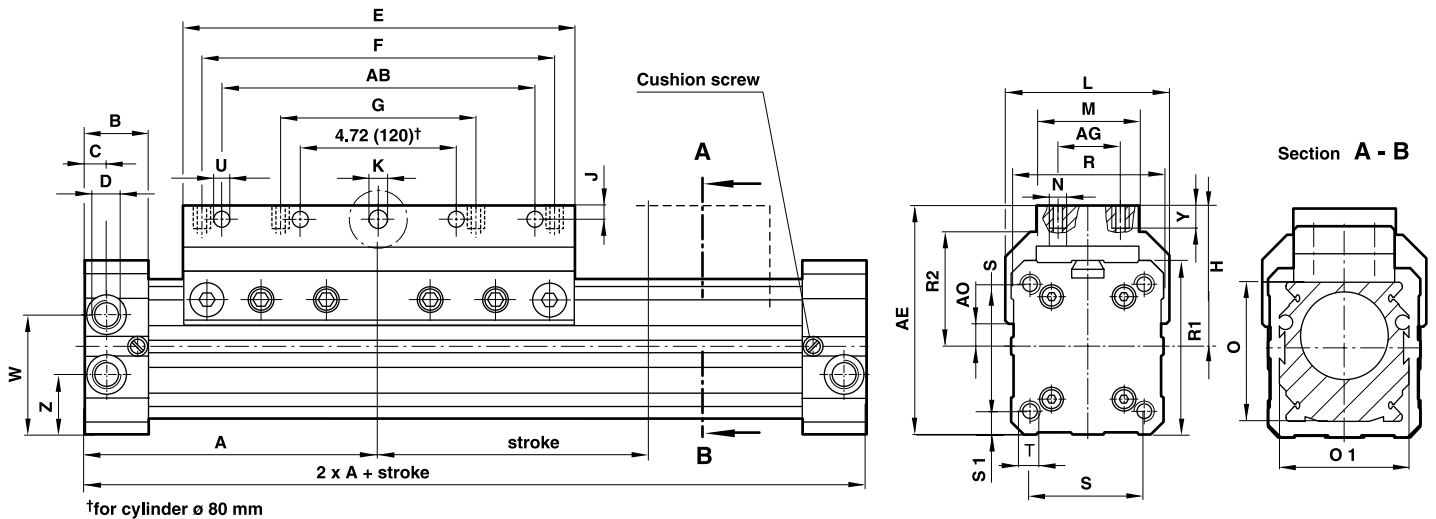

†for cylinder \varnothing 80 mm

Series RL Carriage Options

Standard Cylinder, Externally Guided Carriage

internal guiding / external guiding

BORE	A	AB	AC	AE	AG	AO	B	C	D	E	F	G	J	K	L
16	2.46 (62.5)	–	0.28 (7)	1.50 (38)	0.31 (8)	/0.30 (7.5)	0.69 (18)	0.31 (08)	– M5	3.15 (80)	2.36 (60)	–	0.10 (2.5)	0.12 (3)	1.22 (31)
20	3.34 (85)	/2.36 (60)	0.55 (14)	2.13/2.32 (54/59)	0.71 (18)	/0.26 (6.5)	0.91 (23)	0.31 (08)	1/8 NPT G1/8	4.33 (110)	3.15 (80)	1.57 (40)	0.14/0.30 (3.5/7.5)	0.17 (4.2)	1.65 (42)
25	3.93 (100)	/2.76 (70)	0.47 (12)	2.36/2.66 (60/67.5)	0.79 (20)	/0.37 (9.5)	0.91 (23)	0.57 (14.5)	1/8 NPT G1/8	5.12 (130)	3.54 (90)	1.77 (45)	/0.20 (5)	0.18 (4.5)	2.05 (52)
32	4.72 (120)	/3.54 (90)	0.63 (16)	3.00/3.23 (76/82)	0.98 (25)	/0.61 (15.5)	1.06 (27)	0.41 (10.5)	1/4 NPT G1/4	6.30 (160)	4.72 (120)	2.36 (60)	/0.20 (5)	0.24 (6)	2.52 (64)
40	5.91 (150)	/4.72 (120)	0.60 (15)	3.54/3.84 (90/97.5)	0.98 (25)	/0.65 (16.5)	1.18 (30)	0.45 (11.5)	1/4 NPT G1/4	8.46 (215)	6.30 (160)	3.15 (80)	/0.20 (5)	0.24 (6)	3.11 (79)
50	7.09 (180)	/6.30 (160)	0.79 (20)	4.33/4.61 (110/117)	0.98 (25)	/0.94 (24)	1.38 (35)	0.55 (14)	3/8 NPT G3/8	9.84 (250)	7.48 (190)	3.74 (95)	/0.26 (6.5)	0.32 (8)	3.62 (92)
63	8.46 (215)	/7.48 (190)	0.79 (20)	4.92/5.39 (125/137)	0.98 (25)	/1.00 (25.5)	1.57 (40)	0.67 (17)	1/2 NPT G1/2	12.60 (320)	9.45 (240)	4.72 (120)	/0.30 (7.5)	0.32 (8)	4.33 (110)
80	10.23 (260)	9.45 (240)	0.94 (24)	6.06/6.50 (154/165)	0.98 (25)	/1.50 (38)	1.77 (45)	0.67 (17)	1/2 NPT G1/2	15.35 (390)	11.81 (300)	5.91 (150)	0.35/0.39 (9/10)	0.47 (12)	5.12 (130)

BORE	M	N	O	O1	P	P1	R	R1	R2	S	S1	T	U	W	Y	Z
16	0.71 (18)	M3	0.98 (25)	1.26 (32)	0.47 (12)	–	1.06 (27)	1.22 (31)	/0.73 (18.5)	0.63 (16)	0.22 (5.5)	M3x5 deep	–	–	0.16/0.20 (4/5)	0.63 (16.3)
20	1.06/1.06 (27/27)	M5	1.26 (32)	1.50 (38)	0.73 (18.5)	–	1.57 (40)	1.57 (40)	/0.94 (24)	1.26 (32)	0.16 (4)	M5x12 deep	–	–	0.47 (12)	0.85 (21.5)
25	1.26/1.26 (32/32)	M5	1.57 (40)	1.77 (45)	0.63 (16)	0.30 (7.5)	1.89 (48)	1.89 (48)	/1.34 (34)	1.46 (37)	0.22 (5.5)	M5x13 deep	–	1.30 (33)	0.28/0.47 (7/12)	0.67 (17)
32	1.77/1.77 (45/45)	M5	2.05 (52)	2.05 (52)	0.79 (20)	0.39 (10)	2.36 (60)	2.36 (60)	/1.67 (42.5)	1.85 (47)	0.26 (6.5)	M6x15 deep	–	1.57 (40)	0.31/0.47 (8/12)	0.79 (20)
40	1.77/1.77 (45/45)	M6	2.56 (65)	2.56 (65)	0.79 (20)	0.39 (10)	2.95 (75)	2.95 (75)	/1.95 (49.5)	2.28 (58)	0.33 (8.5)	M8x20 deep	–	1.97 (50)	0.31/0.47 (8/12)	0.98 (25)
50	1.97/1.97 (50/50)	M8	3.15 (80)	3.15 (80)	0.98 (25)	0.51 (13)	3.54 (90)	3.54 (90)	/2.30 (58.5)	2.76 (70)	0.39 (10)	M8x25 deep	–	2.36 (60)	0.43/0.67 (11/17)	1.18 (30)
63	1.97/1.97 (50/50)	M8	3.74 (95)	3.74 (95)	0.98 (25)	0.55 (14)	4.13 (105)	4.13 (105)	/2.68 (68)	3.31 (84)	0.41 (10.5)	M10x25 deep	–	2.76 (70)	0.43/0.79 (11/20)	1.38 (35)
80	1.97/1.97 (50/50)	M10	4.72 (120)	4.72 (120)	0.98 (29)	–	5.12 (130)	5.12 (130)	/3.20 (81)	3.94 (100)	0.59 (15)	M12x25 deep	0.43 (11)	3.54 (90)	0.60/0.98 (15/25)	1.57 (40)

Dimensions in inches (mm)

Series RL Carriage Options

Roller Guided Carriage

Code 000C – Cylinders with precision roller guide

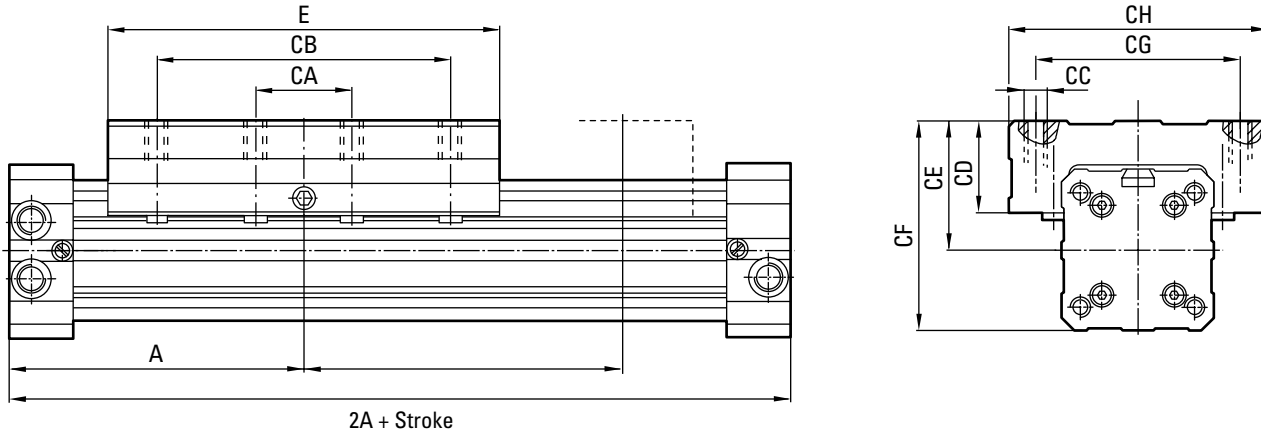

BORE	A	CA	CB	CC	CD	CE	CF	CG	CH	E
25	3.94	1.77	3.54	M6x14 deep	1.42	1.65	2.60	2.36	3.35	5.12
	(100)	(45)	(90)		(36)	(42)	(66)	(60)	(85)	(130)
32	4.72	2.36	4.72	M8x16 deep	1.50	1.97	3.15	2.95	3.86	6.30
	(120)	(60)	(120)		(38)	(50)	(80)	(75)	(98)	(160)
40	5.91	3.15	5.91	M8x16 deep	1.65	2.26	3.74	3.62	4.65	8.46
	(150)	(80)	(150)		(42)	(57.5)	(95)	(92)	(118)	(215)
50	7.09	3.54	7.09	M10x20 deep	1.73	2.64	4.41	3.94	5.20	9.84
	(180)	(90)	(180)		(44)	(67)	(112)	(100)	(132)	(250)
63	8.46	4.72	9.45	M10x20 deep	1.85	2.93	5.00	4.33	5.51	12.60
	(215)	(120)	(240)		(47)	(74.5)	(127)	(110)	(140)	(320)

Dimensions in inches (mm)

Series RL Carriage Options

Right Angle Mounting System, Swinging Bridge

Code 000D – Right angle
mounting system

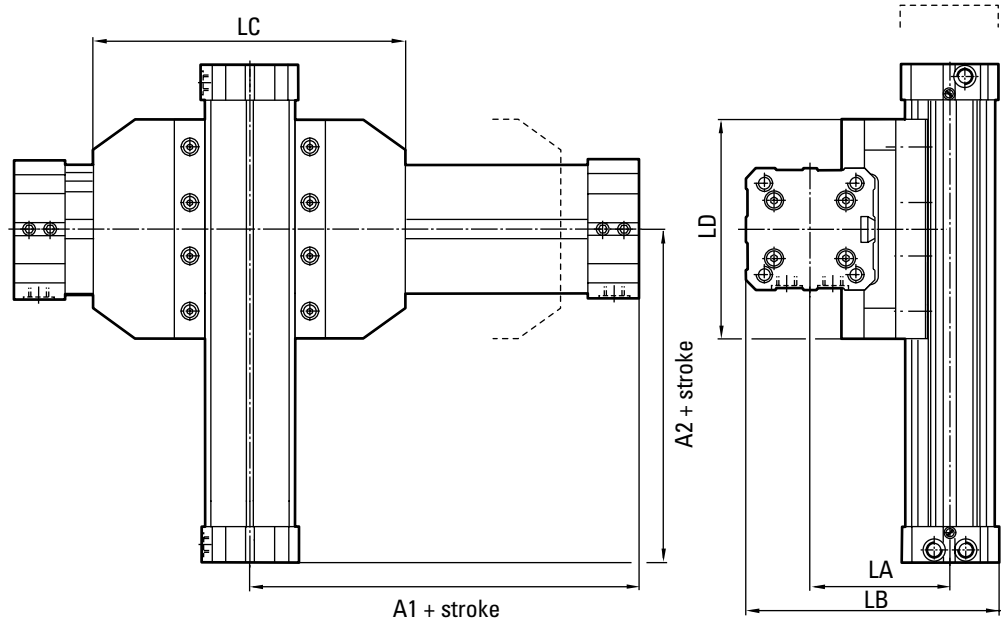

Externally Guided Right Angle Mounting System

BORE	A1	A2	LA	LB	LC	LD
25	3.9 (100)	3.9 (100)	2.7 (69)	4.6 (117)	5.1 (130)	5.1 (130)
25						
32	4.7 (120)	4.7 (120)	3.3 (84)	5.7 (144)	6.3 (160)	6.3 (160)
32						
40	5.9 (150)	5.9 (150)	3.8 (97)	6.8 (172)	8.5 (215)	8.5 (215)
40						
50	7.1 (180)	7.1 (180)	4.6 (116)	8.1 (206)	9.8 (250)	9.8 (250)
50						

Dimensions in inches (mm)

Code 000H – Swinging bridge

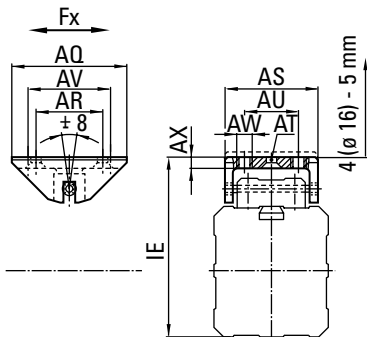

BORE	AQ	AR	AS	AT	AU	AV	AW	AX	IE	FX (N)
16	1.57 (40)	– –	1.02 (26)	– –	0.47 (12)	1.18 (30)	M4	0.16 (4)	1.89 +.16 (48 +4)	3.94 (100)
20	1.97 (50)	1.38 (35)	1.50 (38)	DIN74-Bm5	0.79 (20)	1.57 (40)	M5	0.20 (5)	2.58 +.20 (65.5 +5)	5.91 (150)
25	2.36 (60)	1.57 (40)	1.73 (44)	DIN74-Bm5	0.79 (20)	1.77 (45)	M5	0.20 (5)	2.76 +.20 (70 +5)	9.84 (250)
32	3.15 (80)	1.97 (50)	2.32 (59)	DIN74-Bm6	1.18 (30)	2.36 (60)	M6	0.22 (5.5)	3.48 +.20 (88.5 +5)	16.14 (410)
40	3.15 (80)	1.97 (50)	2.32 (59)	DIN74-Bm6	1.18 (30)	2.36 (60)	M6	0.22 (5.5)	4.04 +.20 (102.5 +5)	25.20 (640)
50	3.94 (100)	2.36 (60)	2.56 (65)	DIN74-Bm8	1.57 (40)	3.15 (80)	M8	0.26 (6.5)	4.88 +.20 (124 +5)	39.37 (1000)
63	3.94 (100)	2.36 (60)	2.56 (65)	DIN74-Bm8	1.57 (40)	3.15 (80)	M8	0.26 (6.5)	5.47 +.20 (139 +5)	59.06 (1500)
80	3.94 (100)	2.36 (60)	2.56 (65)	DIN74-Bm8	1.57 (40)	3.15 (80)	M8	0.26 (6.5)	6.63 +.20 (168.5 +5)	94.49 (2400)

Dimensions in inches (mm)

Note: Additional dimensions available as custom cylinders

Series RL Carriage Options

Carriage Plate Mounting, Side Mounting Plate

Code 000G – Carriage plate mounting

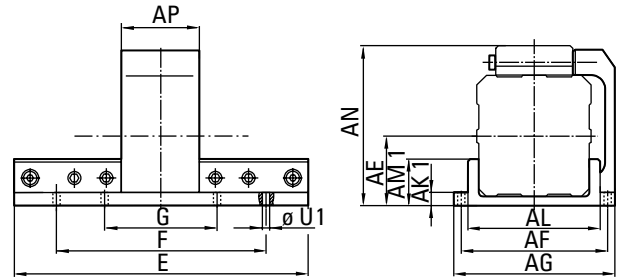

BORE	AE	AF	AG	AK1	AL	AM1	AN	AP	E	F	G	U1
16	0.63 (16)	1.57 (40)	1.97 (50)	0.14 (3.5)	1.22 (31)	0.33 (8.5)	1.59 (40.5)	1.18 (30)	3.15 (80)	2.36 (60)	-	0.22 (5.5)
20	0.85 (21.5)	2.05 (52)	2.44 (62)	0.22 (5.5)	1.65 (42)	0.57 (14.5)	2.20 (56)	1.42 (36)	4.33 (110)	3.15 (80)	1.57 (5.5)	0.22 (06)
25	1.04 (26.5)	2.44 (62)	2.95 (75)	0.22 (5.5)	2.05 (52)	0.69 (17.5)	2.46 (62.5)	1.77 (45)	5.12 (130)	3.54 (90)	1.77 (45)	0.26 (6.6)
32	1.30 (33)	3.07 (78)	3.62 (92)	0.26 (6.5)	2.52 (64)	0.71 (18)	3.11 (79)	2.17 (55)	6.30 (160)	4.72 (120)	2.36 (60)	0.35 (09)
40	1.59 (40.5)	3.70 (94)	4.41 (112)	0.30 (7.5)	3.19 (81)	0.94 (24)	3.66 (93)	2.56 (65)	8.46 (215)	6.30 (160)	3.15 (80)	0.35 (09)
50	1.93 (49)	4.41 (112)	5.20 (132)	0.31 (08)	3.70 (94)	0.98 (25)	4.49 (114)	2.95 (75)	9.84 (250)	7.48 (190)	3.74 (95)	0.43 (11)
63	2.26 (57.5)	5.20 (132)	5.91 (150)	0.39 (10)	4.41 (112)	1.26 (32)	5.12 (130)	3.54 (90)	12.60 (320)	9.45 (240)	4.72 (120)	0.51 (13)
80	2.76 (70)	6.10 (155)	7.09 (180)	0.39 (10)	5.20 (132)	1.26 (32)	6.26 (159)	3.94 (100)	15.35 (390)	11.81 (300)	5.91 (150)	0.55 (14)

Dimensions in inches (mm)

Code 000F – Side mounting plate

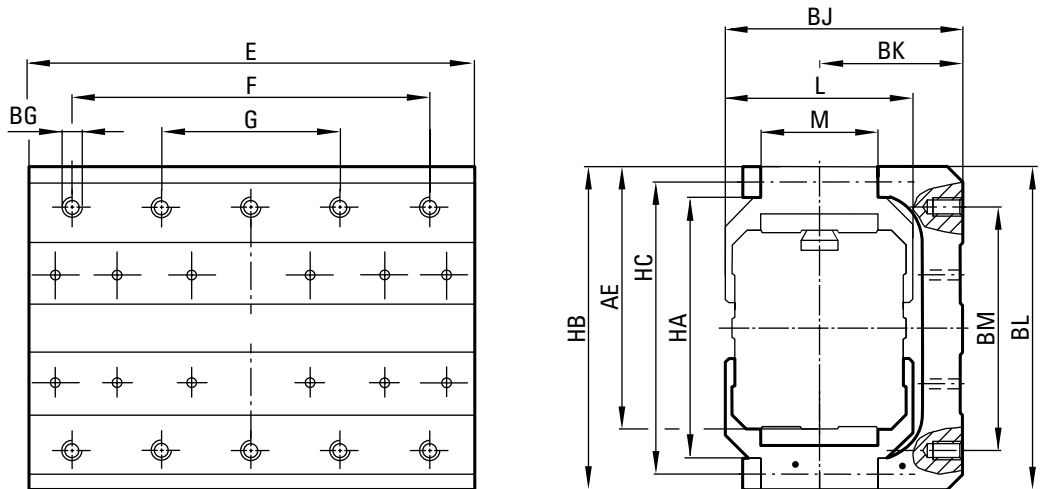







BORE	AE	BG	BJ	BK	BL	BM	E	F	G	HA	HB	HC	L	M
16	1.50 (38)	-	-	-	-	-	3.15 (80)	-	-	-	1.93 (49)	-	-	0.71 (18)
20	2.32 (59)	M5x10 deep	2.13 (54)	1.30 (33)	3.07 (78)	2.17 (55)	4.33 (110)	-	1.57 (40)	2.52 (64)	3.11 (79)	2.52 (64)	1.65 (42)	1.06 (27)
25	2.66 (67.5)	M5x10 deep	2.48 (63)	1.46 (37)	3.39 (86)	2.56 (65)	5.12 (130)	3.15 (80)	1.77 (45)	3.03 (77)	3.43 (87)	3.03 (77)	2.05 (52)	1.26 (32)
32	3.23 (82)	M5x12 deep	3.03 (77)	1.77 (45)	4.06 (103)	3.15 (80)	6.30 (160)	3.54 (90)	2.36 (60)	3.70 (94)	4.09 (104)	3.70 (94)	2.52 (64)	1.77 (45)
40	3.84 (97.5)	M6x12 deep	3.86 (98)	2.30 (58.5)	4.69 (119)	3.54 (90)	8.46 (215)	4.72 (120)	3.15 (80)	4.33 (110)	4.72 (120)	4.33 (110)	3.11 (79)	1.77 (45)
50	4.61 (117)	M6x15 deep	4.63 (117.5)	2.81 (71.5)	5.63 (143)	4.72 (120)	9.84 (250)	6.30 (160)	3.74 (95)	5.16 (131)	5.67 (144)	5.16 (131)	3.62 (92)	1.97 (50)
63	5.39 (137)	M8x20 deep	5.49 (139.5)	3.33 (84.5)	6.61 (168)	5.51 (140)	12.60 (320)	7.48 (190)	4.72 (120)	6.02 (153)	6.65 (169)	6.06 (154)	4.33 (110)	1.97 (50)
80	6.50 (165)	-	-	-	-	-	15.35 (390)	9.45 (240)	-	-	7.87 (200)	-	-	1.97 (50)

Dimensions in inches (mm)

Series RL Accessories

Mountings

	END LUG MOUNT	SWINGING BRIDGE*	CARRIAGE MOUNTING PLATE*	CENTER SUPPORT	SECONDARY CARRIAGE**	SIDE MOUNTING PLATE**
						
BORE						
16	RL/46016/21	RL/46016/37	RL/46016/34	RL/46016/32	RL/46016/35	—
20	RL/46020/21	RL/46020/37	RL/46020/34	RL/46020/32	RL/46020/35	RL/46020/36
25	RL/46025/21	RL/46025/37	RL/46025/34	RL/46025/32	RL/46025/35	RL/46025/36
32	RL/46032/21	RL/46032/37	RL/46032/34	RL/46032/32	RL/46032/35	RL/46032/36
40	RL/46040/21	RL/46040/37	RL/46040/34	RL/46040/32	RL/46040/35	RL/46040/36
50	RL/46050/21	RL/46050/37	RL/46050/34	RL/46050/32	RL/46050/35	RL/46050/36
63	RL/46063/21	RL/46063/37	RL/46063/34	RL/46063/32	RL/46063/35	RL/46063/36
80	RL/46080/21	RL/46080/37	RL/46080/34	RL/46080/32	RL/46080/35	—

* Suitable for internally guided models only. ** Suitable for external guided models only.

Dimensions in inches (mm)

Active Holding Brake System

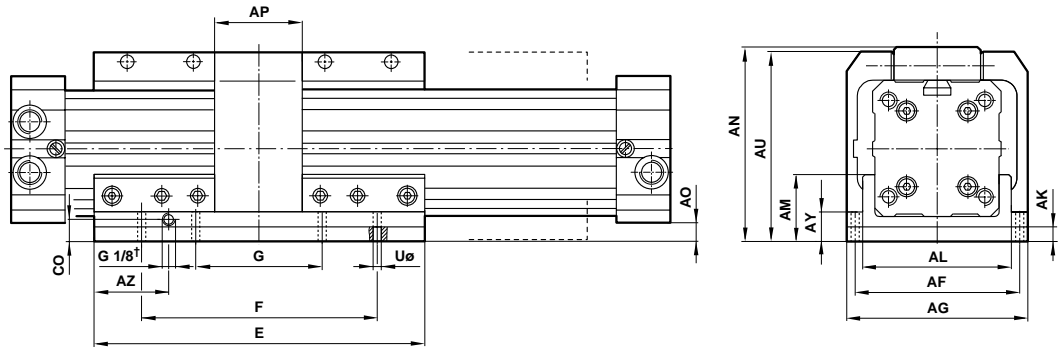
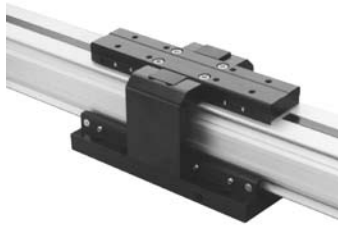

BORE	25 MM	32 MM	40 MM	50 MM	63 MM
NPT	RLC/46025B/L3/*	RLC/46032B/L3/*	RLC/46040B/L3/*	RLC/46050B/L3/*	RLC/46063B/L3/*
ISO	RLM/46025B/L3/*	RLM/46032B/L3/*	RLM/46040B/L3/*	RLM/46050B/L3/*	RLM/46063B/L3/*
AF	2.44 (62)	3.07 (78)	3.70 (94)	4.41 (112)	5.20 (132)
AG	2.95 (75)	3.62 (92)	4.41 (112)	5.20 (132)	5.91 (150)
AK	0.48 (12)	0.48 (12)	0.48 (12)	0.48 (12)	0.48 (12)
AL	2.05 (52)	2.52 (64)	3.19 (81)	3.70 (94)	4.41 (112)
AM	1.12 (28.5)	1.14 (29)	1.36 (34.5)	1.40 (35.5)	1.67 (42.5)
AN	2.89 (73.5)	3.54 (90)	4.07 (103.5)	4.90 (124.5)	5.53 (140.5)
AO	0.53 (13.5)	0.55 (14)	0.53 (13.5)	0.57 (14.5)	0.61 (15.5)
AP	1.77 (45)	2.17 (55)	2.56 (65)	2.95 (75)	3.54 (90)
AU	2.87 (73)	3.52 (89.5)	4.06 (103)	4.88 (124)	5.51 (140)
AY	0.65 (16.5)	0.69 (17.5)	0.71 (18)	0.73 (18.5)	0.81 (20.5)
AZ	1.18 (30)	1.28 (32.5)	2.07 (52.5)	2.56 (65)	4.53 (115)
CO	0.63 (16)	0.71 (18)	0.71 (18)	0.94 (24)	0.94 (24)
E	5.12 (130)	6.30 (160)	8.46 (215)	9.84 (250)	12.60 (320)
F	3.54 (90)	4.72 (120)	6.30 (160)	7.48 (190)	9.45 (240)
G	—	2.36 (60)	3.15 (80)	3.74 (95)	4.72 (120)
UØ	0.26 (6.6)	0.35 (9)	0.35 (9)	0.43 (11)	0.51 (13)

* Stroke length (inches)

Dimensions in inches (mm)

Series RL Accessories

Passive Holding Brake System

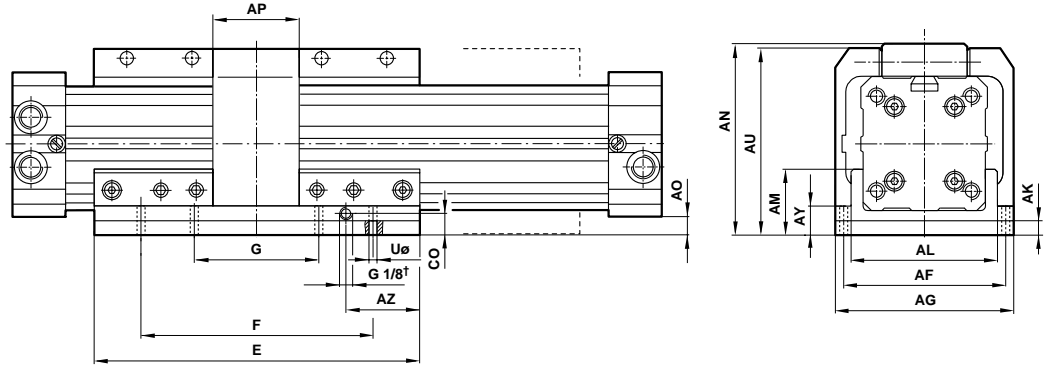

BORE NPT ISO	25 MM RLC/46025B/L4/* RLM/46025B/L4/*	32 MM RLC/46032B/L4/* RLM/46032B/L4/*	40 MM RLC/46040B/L4/* RLM/46040B/L4/*	50 MM RLC/46050B/L4/* RLM/46050B/L4/*	63 MM RLC/46063B/L4/* RLM/46063B/L4/*
AF	2.44 (62)	3.07 (78)	3.70 (94)	4.41 (112)	5.20 (132)
AG	2.95 (75)	3.62 (92)	4.41 (112)	5.20 (132)	5.91 (150)
AK	0.39 (10)	0.47 (12)	0.47 (12)	0.71 (18)	0.71 (18)
AL	2.05 (52)	2.52 (64)	3.19 (81)	3.31 (84)	4.41 (112)
AM	1.52 (38.5)	1.61 (41)	1.83 (46.5)	2.11 (53.5)	2.38 (60.5)
AN	3.29 (83.5)	4.02 (102)	4.55 (115.5)	5.61 (142.5)	6.24 (158.5)
AO	0.93 (23.5)	1.02 (26)	1.00 (25.5)	1.28 (32.5)	1.32 (33.5)
AP	1.77 (45)	2.17 (55)	2.56 (65)	2.95 (75)	3.54 (90)
AU	3.27 (83)	4.00 (101.5)	4.53 (115)	5.59 (142)	6.22 (158)
AY	1.04 (26.5)	1.16 (29.5)	1.18 (30)	1.44 (36.5)	1.52 (38.5)
AZ	1.18 (30)	1.28 (32.5)	2.07 (52.5)	2.56 (65)	4.53 (115)
CO	0.63 (16)	0.71 (18)	0.71 (18)	0.94 (24)	0.94 (24)
E	5.12 (130)	6.30 (160)	8.46 (215)	9.84 (250)	12.60 (320)
F	3.54 (90)	4.72 (120)	6.30 (160)	7.48 (190)	9.45 (240)
G	—	2.36 (60)	3.15 (80)	3.74 (95)	4.72 (120)
UØ	0.26 (6.6)	0.35 (9)	0.35 (9)	0.43 (11)	0.51 (13)

* Stroke length (inches)
Dimensions in inches (mm)

Series RL Technical Information

Operating Temperature

-22° to 180°F* (-30°C to 80°C)

*With dewpoint of supply air less than ambient air temperature.

Operating Pressure

16 mm: 22 to 150 psi
(1.5 to 10 bar)

20 mm to 80 mm: 15 to 150 psi
(1 to 10 bar)

BORE SIZES:	AREA (SQ. IN.)
16 mm bore — 0.63"	.31
20 mm bore — 0.79"	.49
25 mm bore — 0.98"	.75
32 mm bore — 1.26"	1.25
40 mm bore — 1.57"	1.94
50 mm bore — 1.97"	3.05
63 mm bore — 2.48"	4.83
80 mm bore — 3.15"	7.79

Stroke lengths:

16 mm to 40 mm bore - to 28 ft. (8500 mm)

50 mm and 63 mm bore - to 23 ft. (7000)

80 mm bore - to 18 ft. (5500 mm)

Supply Fluid: Compressed air filtered to 50-microns and lubricated.

Materials of Construction

Tube and Carriage: Anodized aluminum

End Caps: 16 mm - molded plastic end caps and yoke.
20 mm - anodized aluminum end covers, molded plastic yoke.
25 to 80 mm - anodized aluminum end caps and yoke.

Seal Strips and Piston Seals: Polyurethane

Cover Strips: Polyamide

Guide Rails: UHMW Polymer

Seals: Nitrile rubber or Polyurethane

THRUST – Based on 75% of Maximum Thrust

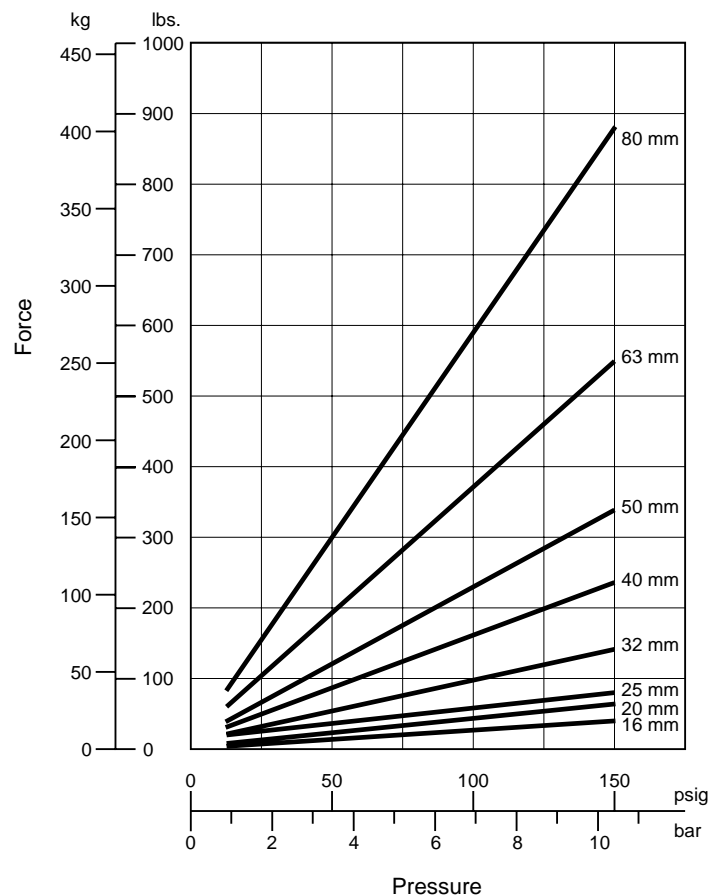

Series RL Technical Information

Cushioning Performance

The dynamic energy of a RL cylinder is caused by direct or partial external loads which must be absorbed by pneumatic cushioning. The cushioning ability depends to a large extent on the pneumatic circuit (e. g. counter pressure, pre-exhaust). The values given in the diagram were tested with an operation pressure of 87 psi (6 bar)

using a 5/2 control valve. When installed horizontally, depending upon the speed, dynamic energy can be absorbed by the cylinder. Whenever the values given in the diagram are exceeded, the transported mass must be cushioned by additional shock absorbers. These have to be located at the center of gravity of the mass.

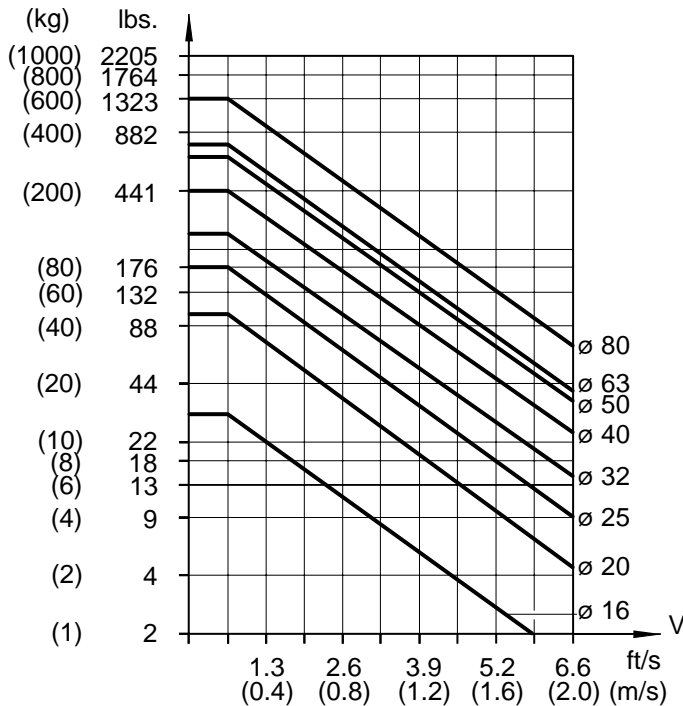

Loading values for RL cylinders

The values given in the table below show the single forces in the directions F_y and F_z and the maximum moments M_x , M_y and M_z . All values are applicable only for speeds of max. 0.66 ft/s (0.2 m/s). A requirement for using these values is a constant movement (no jerking) of the mass over the whole stroke length of the cylinder. The reference point from which the moments for all cylinders should be calculated is the centerline of the piston.

Total loads

When a Lintra cylinder has to take several loads and moments, an additional calculation is necessary using this formula:

$$\frac{M_x}{M_{x \max}} + \frac{M_y}{M_{y \max}} + \frac{M_z}{M_{z \max}} + \frac{F_y}{F_{y \max}} + \frac{F_z}{F_{z \max}} \leq 1$$

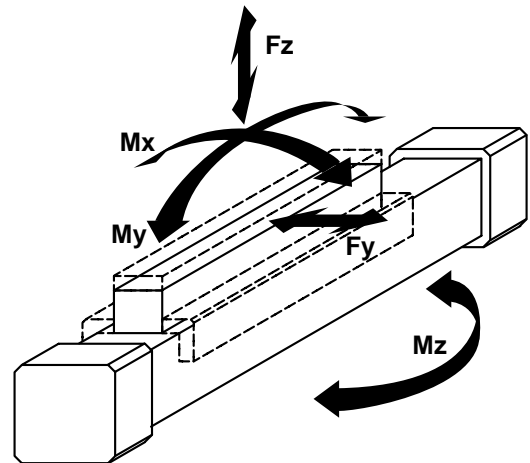

Series RL Technical Information

Cylinder Weights

Cylinder with Internal Guide

BORE	MOUNTING CODES:		
	AS SIDE LUG	ES END LUG	KS NO MOUNT
16	.37 (0.17)	.37 (0.17)	.35 (0.16)
20	1.17 (0.53)	1.17 (0.53)	1.10 (0.50)
25	1.75 (0.81)	1.85 (2.74)	1.76 (0.80)
32	3.75 (1.70)	3.68 (1.67)	3.53 (1.60)
40	6.39 (2.90)	6.39 (2.90)	5.95 (2.70)
50	11.24 (5.10)	6.39 (2.90)	10.58 (4.80)
63	16.76 (7.60)	11.24 (5.10)	15.88 (7.20)
80	29.99 (13.60)	29.99 (13.60)	29.11 (13.20)

Cylinder with Roller Carriage:

BORE	MOUNTING CODES:		
	AS SIDE LUG	ES END LUG	KS NO MOUNT
16	—	—	—
20	—	—	—
25	3.77 (1.71)	3.84 (1.74)	3.75 (1.70)
32	7.06 (3.20)	6.99 (3.17)	6.84 (3.10)
40	11.47 (5.20)	11.47 (5.20)	11.03 (5.00)
50	20.73 (9.40)	20.73 (9.40)	20.07 (9.10)
63	31.53 (14.30)	31.53 (14.30)	30.65 (13.90)
80	—	—	—

Cylinder with External Guide

BORE	MOUNTING CODES:		
	AS SIDE LUG	ES END LUG	KS NO MOUNT
16	.42 (0.19)	.42 (0.19)	.40 (0.18)
20	1.39 (0.63)	1.39 (0.63)	1.32 (0.60)
25	2.00 (0.91)	2.07 (0.94)	1.98 (0.90)
32	3.97 (1.80)	3.90 (1.77)	3.75 (1.70)
40	6.83 (3.10)	6.83 (3.10)	6.39 (2.90)
50	11.46 (5.20)	11.46 (5.20)	10.80 (4.90)
63	17.86 (8.10)	17.86 (8.10)	16.98 (7.70)
80	30.43 (13.80)	30.43 (13.80)	29.55 (13.40)

Cylinder with Right Angle Mounting

BORE	MOUNTING CODES:		
	AS SIDE LUG	ES END LUG	KS NO MOUNT
16	—	—	—
20	—	—	—
25	4.21 (1.91)	4.28 (1.94)	4.19 (1.90)
32	7.06 (3.20)	6.99 (3.17)	6.84 (3.10)
40	12.34 (5.60)	12.34 (5.60)	11.90 (5.40)
50	24.48 (8.70)	24.48 (8.70)	23.82 (8.40)
63	—	—	—

Cylinder weights lbs (kgs)

Series BL Features

Series BL Features / Benefits

A. Piston Seals

Lip-type carboxylated nitrile incorporating Teflon® and other non-lube additives as integral parts of the compound. Extremely smooth stroke performance and “no lube added” operation results from reduced friction.

B. Piston

Solid aluminum alloy, light-weight for low inertia, yet strong.

C. Head/Cap

Precision machined from (6061-T6) solid aluminum bar, anodized for corrosion resistance

D. Rod Wiper

Lip-type urethane aggressively wipes foreign material from piston rod.

E. Rod Seals

Rounded lip-type carboxylated nitrile incorporating Teflon® and other non-lube additives as integral parts of the compound. Extremely smooth stroke performance and “no lube added” operation results from reduced friction. Rod Seal is pressure-energized and wear-compensating.

F. Piston Rods

High-strength, hard-chrome plated, ground and polished steel.

G. Ultra Cushion®

State-of-the-art design features a unique, one-piece, nitrile compound seal, captured within a precision machined groove. Linear and radial “float” of cushion seal eliminates misalignment. Ultra

Cushions provide exceptionally fast “out of cushion” stroke reversal. (Head and Cap Cushions are optional.)

H. Adjustable Captive Cushion Needle

I. Wear Strip

Teflon® and graphite composition for minimum friction, maximum wear and side load resistance. (Magnetic band under wear strip optional.)

J. Tube

6063-T832 aluminum alloy ideally suited for air service. Tube is clear anodized on the O.D. and “hard anodic coated” on the I.D. resulting in a smooth, file-hard (60RC), corrosion-resistant and score-resistant surface finish.

K. Tie Rods

High-strength steel maintains compression on tube end seals.

L. Retainer

High-strength steel is used to retain rod bearings.

M. Rod Bearings

Machined from durable, close-grained cast iron, then completely coated with Teflon® to insure permanent lubrication and corrosion resistance.

N. Tooling Plate

Machined from solid steel and notched for secure attachment. Modular and pilot adaptor plates are available to add to the tooling plate mounting. (Use of modular and pilot adapter plates adds to overall length.)

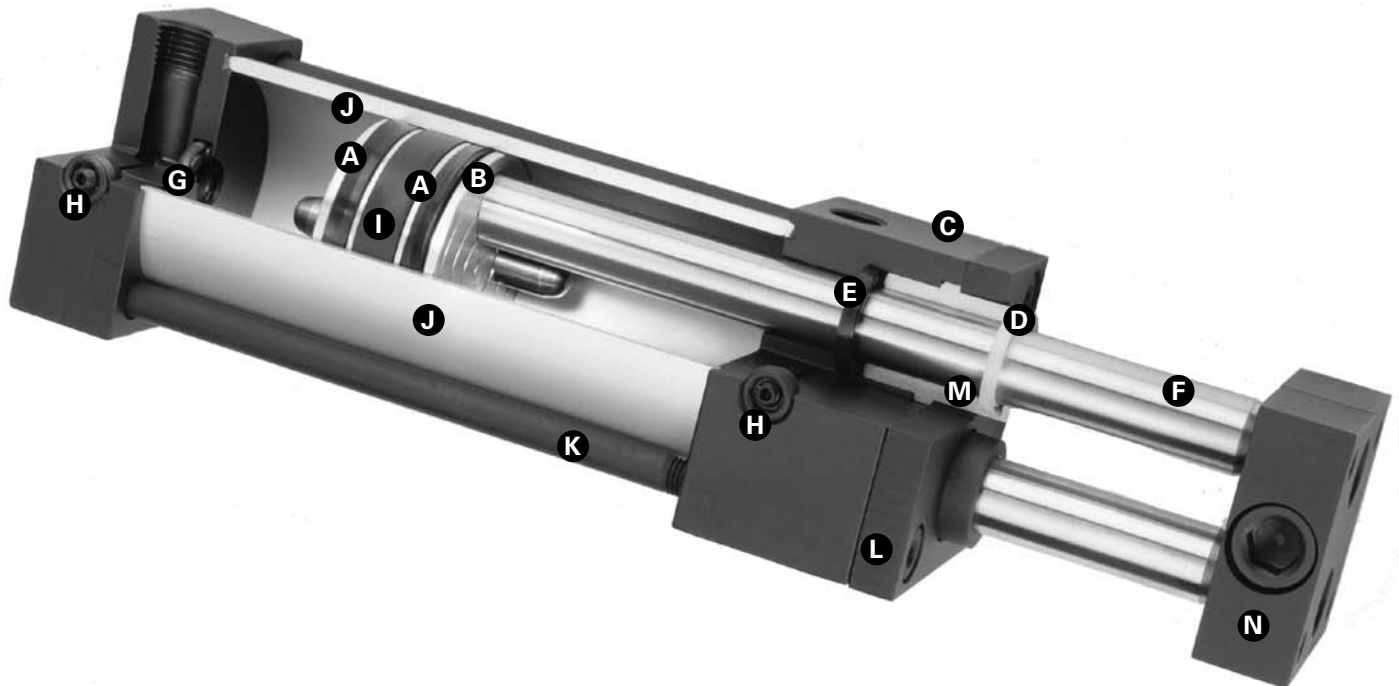

Series BL Model Code

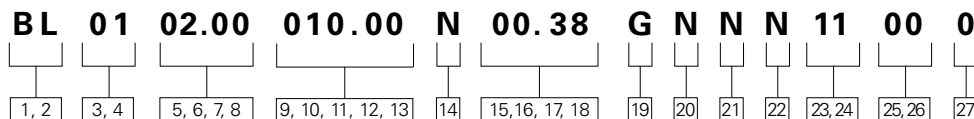

1, 2 Series

BL – Non-Rotating Cylinders

3, 4 Mounting Styles

- AS** – Side Lug -
- BS** – Side Tapped MS4
- FS** – Head Rectangular Flange MF1
- RS** – Cap Rectangular Flange MF2
- KS** – No Mount MX0
- AD** – Double Rod, Side Lug -
- BD** – Double Rod, Tapped -
- FD** – Double Rod, Rectangular Flange -
- KD** – Double Rod, No Mount -
- DE** – Detachable Eye MP4
- DC** – Detachable Clevis MP2
- XX** – Custom

5, 6, 7, 8 Bore

Specify in inches
(2 position decimal)

- 01.13 – 1-1/8" bore
- 01.50 – 1-1/2" bore
- 02.00 – 2" bore
- 02.50 – 2-1/2" bore
- 03.25 – 3-1/4" bore
- 04.00 – 4" bore

9, 10, 11, 12, 13 Stroke

Specify length in inches
(3 positions to the left of decimal and 2 positions to the right) For example:

Code	Size
004.50	4.5"
010.00	10"
112.50	112.5"

14 Cushions

Code	Head	Cap
N	-	-
C	-	2
H	2	-
B	2	2
A	1	-
D	3	-
E	4	-
F	-	1
G	-	3
J	-	4

15, 16, 17, 18 Rod Diameter

Specify in inches
(2 position decimal)

Code	Size
00.31	5/16" Rod Dia.
00.38	3/8" Rod Dia.
00.63	5/8" Rod Dia.
01.00	1" Rod Dia.

19 Rod End Types

Code	Type
G	Grooved Rod End Horizontal
V	Grooved Rod End Vertical

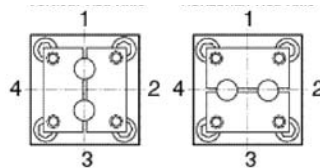

20 Ports

N – Standard NPTF

21 Rod Seals

N – Normal
V – High Temperature

22 Rod Seals

N – Normal
V – High Temperature

23, 24 Port Location

Code	Head	Cap
11	1	1
22	2	2
33	3	3
44	4	4

25, 26 Special Modifications

Extra Rod Projection

Item 25 indicates inches from 0 thru 9. Item 26 indicates fraction of an inch per the following codes:

Code	Fraction	Code	Fraction
0	0	8	1/2
1	1/16	9	9/16
2	1/8	A	5/8
3	3/16	B	11/16
4	1/4	C	3/4
5	5/16	D	13/16
6	3/8	E	7/8
7	7/16	F	15/16

– OR –

Proximity Switch Magnet

PK – Magnet Furnished to operate Hall Effect or Reed Type Switch

– OR –

Rod Material Options

RT – Stainless Steel 300 Series

– OR –

Bronze Option

BS – Bronze Scraper

27 Custom

X – Custom Modification

Series BL Mounting Styles and Installation Dimensions

Available Mountings

The variety of NFPA mountings available in the Series BL gives you a broad selection to match the proper mount to your application. Eaton offers rigid mounts (including side lug mounts and flange mounts) and swivel mounts (including clevis mounts). A guide to proper mount selection is provided on pages 106 through 111. For custom mounts, enter "XX" for model code positions 3 and 4, and give a detailed description with drawings. Series BL cylinders are available in all mounting styles listed.

Selecting the Proper Mounting

Just as the cylinder bore must be sized to provide the proper force for an application, a cylinder mounting that can absorb these application forces must also be specified. Note: In the mounting information, some mounts have been downrated to minimize deflection. For applications where the motion is linear and parallel to the cylinder rod motion, a rigid mount is recommended. For curvilinear motion, a swivel mount should be chosen. The specifics of each application dictate the correct mounting style.

**Code KS –
No Mount (MXO)**



**Code AS –
Side Lug**



**Code BS –
Side Tapped (MS4)**



**Code FS – Head
Rectangular Flange (MF1)**



**Code RS – Cap Rectangular
Flange (MF2)**



**Code DE – Detachable Eye
(MP4)**



**Code DC – Detachable
Clevis (MP2)**



**Code KD –
Double Rod, No Mount**



**Code BD –
Double Rod, Tapped with
Side Tap (MS4)**



**Code AD –
Double Rod, Side Lug**



**Code FD – Double Rod,
Rectangular Flange with
Code FS Flange (MF1)**



Series BL Mounting Styles and Installation Dimensions

1-1/8" to 4" bore sizes

Code KS –
No Mount (MX0)

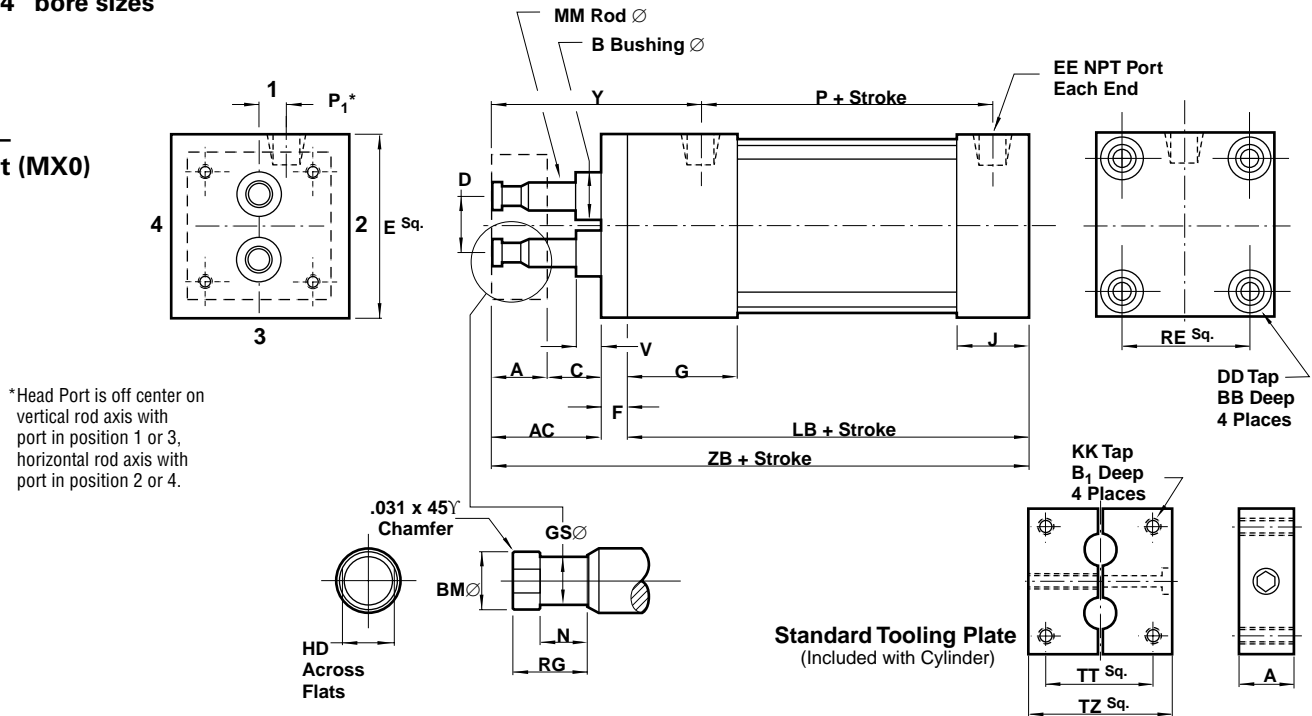

DIMENSION	.1-1/8" BORE (28.58)		.1-1/2" BORE (38.10)		.2" BORE (50.80)		.2-1/2" BORE (63.50)		.3-1/4" BORE (82.55)		.4" BORE (101.60)	
A	.625	(15.88)	.625	(15.88)	.750	(19.05)	.750	(19.05)	1.250	(31.75)	1.250	(31.75)
AC	1.250	(31.75)	1.500	(38.10)	1.500	(38.10)	1.750	(44.45)	1.750	(44.45)	1.750	(44.45)
B	N/A		.590	(14.99)	.900	(22.86)	.900	(22.86)	1.498	(38.05)	1.498	(38.05)
B1	.500	(12.70)	Thru		Thru		Thru		Thru		Thru	
BB	.188	(4.78)	.312	(7.92)	.312	(7.92)	.312	(7.92)	.437	(11.10)	.437	(11.10)
BM	.270	(6.86)	.330	(8.38)	.550	(13.97)	.550	(13.97)	.900	(22.86)	.900	(22.86)
C	.625	(15.88)	.875	(22.23)	.750	(19.05)	1.000	(25.40)	.500	(12.70)	.500	(12.70)
D	.627	(15.93)	.750	(19.05)	1.052	(26.72)	1.398	(35.51)	2.000	(50.80)	2.360	(59.94)
DD	10 – 32		1/4 – 28		5/16 – 24		5/16 – 24		3/8 – 24		3/8 – 24	
E	1.500	(38.10)	2.000	(50.80)	2.500	(63.50)	3.000	(76.20)	3.750	(95.25)	4.500	(114.30)
EE	1/8		1/4		1/4		1/4		3/8		3/8	
F	.250	(6.35)	.375	(9.53)	.375	(9.53)	.375	(9.53)	.625	(15.88)	.625	(15.88)
G	1.000	(25.4)	1.500	(38.10)	1.500	(38.10)	1.500	(38.10)	1.750	(44.45)	1.750	(44.45)
GS	.190	(4.83)	.250	(6.35)	.500	(12.70)	.500	(12.70)	.750	(19.05)	.750	(19.05)
HD	.250	(6.35)	.312	(7.92)	.500	(12.70)	.500	(12.70)	.812	(20.62)	.812	(20.62)
J	.625	(15.88)	1.000	(25.40)	1.000	(25.40)	1.000	(25.40)	1.250	(31.75)	1.250	(31.75)
KK	6 – 32		10 – 32		1/4 – 28		5/16 – 24		3/8 – 24		3/8 – 24	
LB	2.250	(57.15)	3.625	(92.08)	3.625	(92.08)	3.750	(95.25)	4.250	(107.95)	4.250	(107.95)
MM	.312	(7.92)	.375	(9.53)	.625	(15.88)	.625	(15.88)	1.000	(25.40)	1.000	(25.40)
N	.400	(10.16)	.400	(10.16)	.526	(13.36)	.526	(13.36)	.784	(19.81)	.784	(19.81)
P	1.469	(37.31)	2.125	(53.98)	2.125	(53.98)	2.250	(57.15)	2.625	(66.68)	2.625	(66.68)
P1	.241	(6.12)	.303	(7.70)	.480	(12.19)	.635	(16.13)	.845	(21.46)	.875	(22.23)
RE	1.125	(28.58)	1.428	(36.27)	1.840	(46.74)	2.192	(55.68)	2.758	(70.05)	3.323	(84.40)
RG	.580	(14.73)	.580	(14.73)	.705	(17.91)	.705	(17.91)	1.205	(30.61)	1.205	(30.61)
TT	.750	(19.05)	1.125	(28.58)	1.430	(36.32)	1.840	(46.74)	1.790	(45.47)	3.440	(87.38)
TZ	1.250	(31.75)	1.500	(38.10)	2.000	(50.80)	2.500	(63.50)	3.250	(82.55)	4.000	(101.60)
V	N/A		.250	(6.35)	.250	(6.35)	.250	(6.35)	.250	(6.35)	.250	(6.35)
Y	2.031	(51.59)	2.875	(73.03)	2.875	(73.03)	3.125	(79.38)	3.437	(87.30)	3.437	(87.30)
ZB	3.750	(95.25)	5.500	(139.70)	5.500	(139.70)	5.875	(149.23)	6.625	(168.28)	6.625	(168.28)

Series BL Mounting Styles and Installation Dimensions

1-1/8" to 4" bore sizes

Code AS – Side Lug (not NFPA)

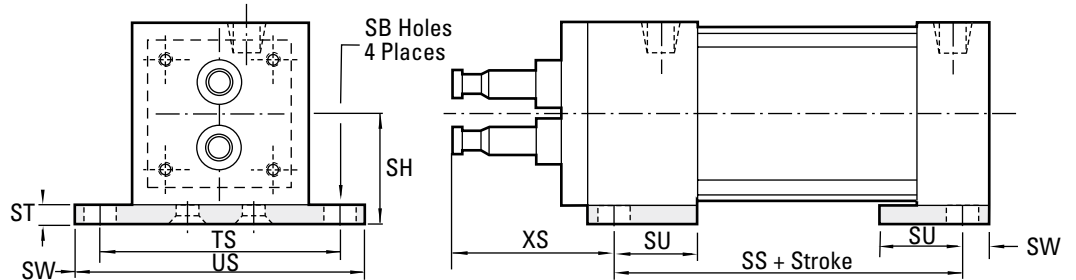

DIMENSION	.1-1/8" BORE (28.58)	.1-1/2" BORE (38.10)	.2" BORE (50.80)	.2-1/2" BORE (63.50)	.3-1/4" BORE (82.55)	.4" BORE (101.60)
SH	1.000 (25.40)	1.250 (31.75)	1.500 (38.10)	1.875 (47.63)	2.375 (60.33)	2.750 (69.85)
SS	1.750 (44.45)	2.875 (73.03)	2.875 (73.03)	3.000 (76.20)	3.250 (82.55)	3.250 (82.55)
ST	.250 (6.35)	.250 (6.35)	.250 (6.35)	.375 (9.53)	.500 (12.70)	.500 (12.70)
SU	.750 (19.05)	1.125 (25.58)	1.125 (25.58)	1.125 (25.58)	1.250 (31.75)	1.250 (31.75)
SW	.250 (6.35)	.375 (9.53)	.375 (9.53)	.375 (9.53)	.500 (12.70)	.500 (12.70)
TS	1.875 (47.63)	2.750 (69.85)	3.250 (82.55)	3.750 (95.25)	4.750 (120.65)	5.500 (139.70)
US	2.375 (60.33)	3.500 (88.90)	4.000 (101.60)	4.500 (114.30)	5.750 (146.05)	6.500 (165.10)
XS	1.750 (44.45)	2.250 (57.15)	2.250 (57.15)	2.500 (63.50)	2.875 (73.03)	2.875 (73.03)

Code BS – Side Tapped (MS4)

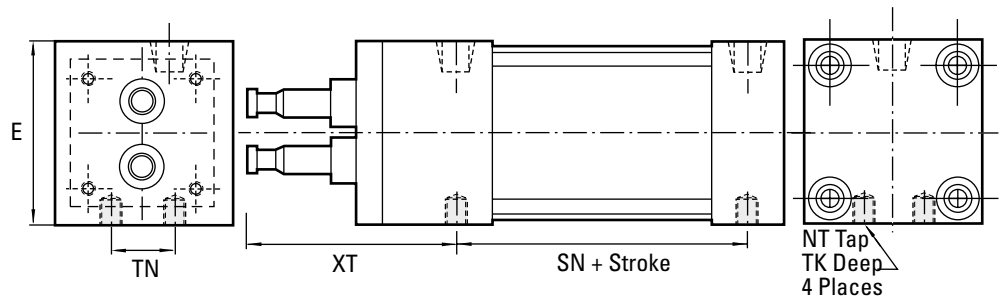

DIMENSION	.1-1/8" BORE (28.58)	.1-1/2" BORE (38.10)	.2" BORE (50.80)	.2-1/2" BORE (63.50)	.3-1/4" BORE (82.55)	.4" BORE (101.60)
E	1.500 (38.10)	2.000 (50.80)	2.500 (63.50)	3.000 (76.20)	3.750 (95.25)	4.500 (114.30)
NT	10 – 32	1/4 – 20	5/16 – 18	3/8 – 16	1/2 – 13	1/2 – 13
SN	1.500 (38.10)	2.250 (57.15)	2.250 (57.15)	2.375 (60.33)	2.625 (66.68)	2.625 (66.68)
TK	.250 (6.35)	.375 (9.53)	.375 (9.53)	.625 (15.88)	.625 (15.88)	.750 (19.05)
TN	.500 (12.70)	.625 (15.88)	.875 (22.23)	1.250 (31.75)	1.500 (38.10)	2.063 (52.40)
XT	2.000 (50.80)	2.812 (71.42)	2.812 (71.42)	3.063 (77.80)	3.437 (87.30)	3.437 (87.30)

Series BL Mounting Styles and Installation Dimensions

1-1/8" to 4" bore sizes

Code FS – Head Rectangular Flange (MF1)

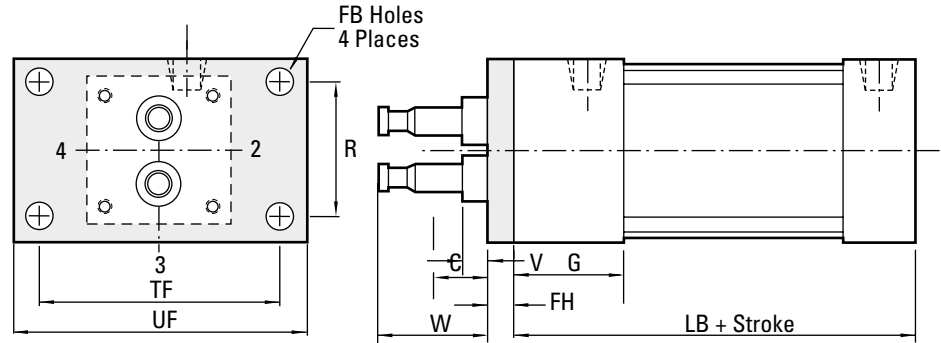

DIMENSION	.1-1/8" BORE (28.58)		.1-1/2" BORE (38.10)		.2" BORE (50.80)		.2-1/2" BORE (63.50)		.3-1/4" BORE (82.55)		.4" BORE (101.60)	
C	.625	(15.88)	.875	(22.23)	.750	(19.05)	1.000	(25.40)	.500	(12.70)	.500	(12.70)
FB	.219	(5.56)	.312	(7.92)	.375	(9.53)	.375	(9.53)	.437	(11.10)	.437	(11.10)
FH	.250	(6.35)	.375	(9.53)	.375	(9.53)	.375	(9.53)	.625	(15.88)	.625	(15.88)
G	1.000	(25.4)	1.500	(38.10)	1.500	(38.10)	1.500	(38.10)	1.750	(44.45)	1.750	(44.45)
LB	2.250	(57.15)	3.625	(92.08)	3.625	(92.08)	3.750	(95.25)	4.250	(107.95)	4.250	(107.95)
R	1.000	(25.40)	1.430	(36.32)	1.840	(46.74)	2.190	(55.63)	2.760	(70.10)	3.320	(84.33)
TF	2.000	(50.80)	2.750	(69.85)	3.375	(85.73)	3.875	(98.43)	4.688	(119.08)	5.437	(138.10)
UF	2.500	(63.50)	3.750	(95.25)	4.125	(104.78)	4.625	(117.48)	5.500	(139.70)	6.250	(158.75)
V	N/A		.250	(6.35)	.250	(6.35)	.250	(6.35)	.250	(6.35)	.250	(6.35)
W	1.250	(31.75)	1.500	(38.10)	1.500	(38.10)	1.750	(44.45)	1.750	(44.45)	1.750	(44.45)

Code RS – Cap Rectangular Flange (MF2)

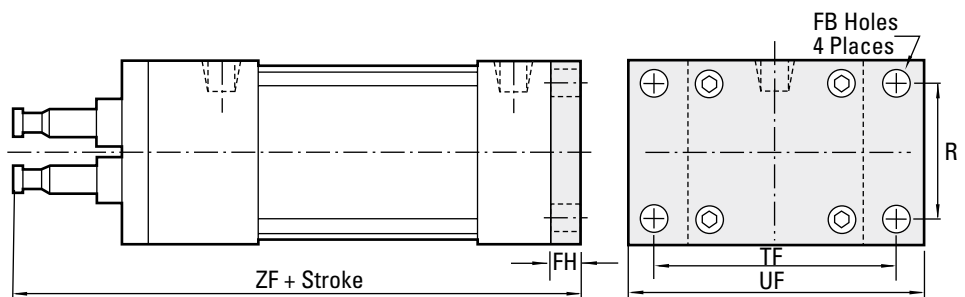

DIMENSION	.1-1/8" BORE (28.58)		.1-1/2" BORE (38.10)		.2" BORE (50.80)		.2-1/2" BORE (63.50)		.3-1/4" BORE (82.55)		.4" BORE (101.60)	
FB	.219	(5.56)	.312	(7.92)	.375	(9.53)	.375	(9.53)	.437	(11.10)	.437	(11.10)
FH	.250	(6.35)	.375	(9.53)	.375	(9.53)	.375	(9.53)	.625	(15.88)	.625	(15.88)
R	1.000	(25.40)	1.430	(36.32)	1.840	(46.74)	2.190	(55.63)	2.760	(70.10)	3.320	(84.33)
TF	2.000	(50.80)	2.750	(69.85)	3.375	(85.73)	3.875	(98.43)	4.688	(119.08)	5.437	(138.10)
UF	2.500	(63.50)	3.750	(95.25)	4.125	(104.78)	4.625	(117.48)	5.500	(139.70)	6.250	(158.75)
ZB	3.750	(95.25)	5.500	(139.70)	5.500	(139.70)	5.875	(149.23)	6.625	(168.28)	6.625	(168.28)
ZF	4.000	(101.60)	5.875	(149.23)	5.875	(149.23)	6.250	(158.75)	7.250	(184.15)	7.250	(184.15)

Series BL Mounting Styles and Installation Dimensions

1-1/8" to 4" bore sizes

Code DC – Detachable Clevis (MP2)

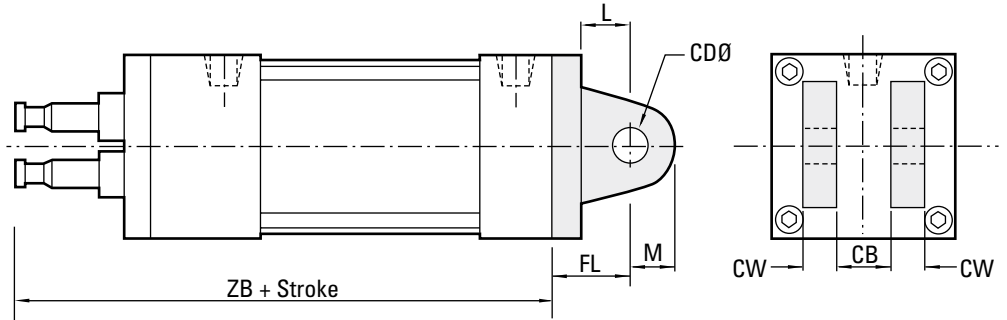

DIMENSION	.1-1/8" BORE (28.58)	.1-1/2" BORE (38.10)	.2" BORE (50.80)	.2-1/2" BORE (63.50)	.3-1/4" BORE (82.55)	.4" BORE (101.60)
CB	.375 (9.53)	.750 (19.05)	.750 (19.05)	.750 (19.05)	1.250 (31.75)	1.250 (31.75)
CD	.375 (9.53)	.500 (12.70)	.500 (12.70)	.500 (12.70)	.750 (19.05)	.750 (19.05)
CW	.250 (6.35)	.500 (12.70)	.500 (12.70)	.500 (12.70)	.625 (15.88)	.625 (15.88)
FL	1.125 (28.58)	1.125 (28.58)	1.125 (28.58)	1.125 (28.58)	1.875 (47.63)	1.875 (47.63)
L	.625 (15.88)	.750 (19.05)	.750 (19.05)	.750 (19.05)	1.250 (31.75)	1.250 (31.75)
M	.375 (9.53)	.625 (15.88)	.625 (15.88)	.625 (15.88)	.875 (22.23)	.875 (22.23)
ZB	3.750 (95.25)	5.500 (139.70)	5.500 (139.70)	5.875 (149.23)	6.625 (168.28)	6.625 (168.28)

Code DE – Detachable Eye (MP4)

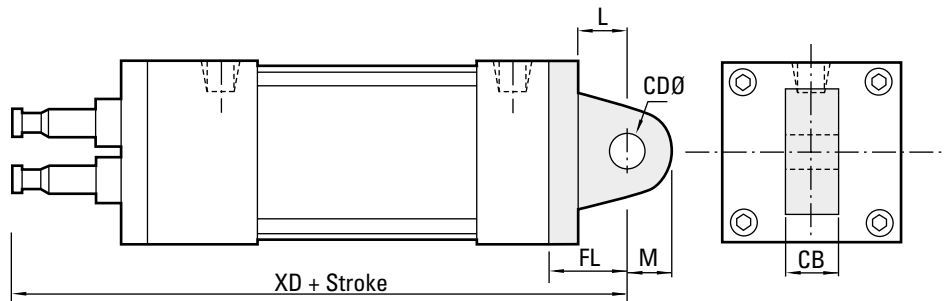

DIMENSION	.1-1/8" BORE (28.58)	.1-1/2" BORE (38.10)	.2" BORE (50.80)	.2-1/2" BORE (63.50)	.3-1/4" BORE (82.55)	.4" BORE (101.60)
CB	.375 (9.53)	.750 (19.05)	.750 (19.05)	.750 (19.05)	1.250 (31.75)	1.250 (31.75)
CD	.375 (9.53)	.500 (12.70)	.500 (12.70)	.500 (12.70)	.750 (19.05)	.750 (19.05)
FL	1.125 (28.58)	1.125 (28.58)	1.125 (28.58)	1.125 (28.58)	1.875 (47.63)	1.875 (47.63)
L	.625 (15.88)	.750 (19.05)	.750 (19.05)	.750 (19.05)	1.250 (31.75)	1.250 (31.75)
M	.375 (9.53)	.625 (15.88)	.625 (15.88)	.625 (15.88)	.875 (22.23)	.875 (22.23)
XD	4.875 (123.83)	6.625 (168.28)	6.625 (168.28)	7.000 (177.80)	8.375 (212.73)	8.375 (212.73)

Series BL Mounting Styles and Installation Dimensions

1-1/8" to 4" bore sizes

Code KD – Double Rod, No Mounts

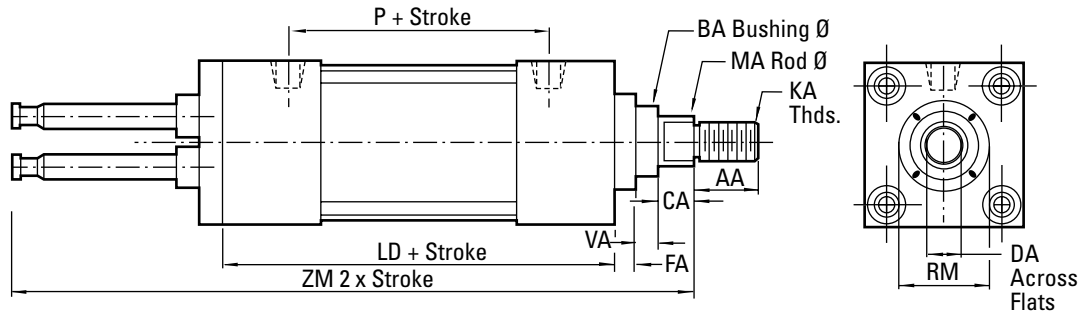

DIMENSION	.1-1/8" BORE (28.58)	.1-1/2" BORE (38.10)	.2" BORE (50.80)	.2-1/2" BORE (63.50)	.3-1/4" BORE (82.55)	.4" BORE (101.60)
AA Standard	.625 (15.88)	.750 (19.05)	.750 (19.05)	.750 (19.05)	1.125 (28.58)	1.125 (28.58)
AA Oversize	.750 (19.05)	1.125 (28.58)	1.125 (28.58)	1.125 (28.58)	1.625 (41.28)	1.625 (41.28)
BA Standard	N/A	1.125 (28.58)	1.125 (28.58)	1.125 (28.58)	1.500 (38.10)	1.500 (38.10)
BA Oversize	N/A	1.400 (35.56)	1.500 (38.10)	1.500 (38.10)	2.000 (50.80)	2.000 (50.80)
CA Standard	.250 (6.35)	.375 (9.53)	.375 (9.53)	.375 (9.53)	.500 (12.70)	.500 (12.70)
CA Oversize	.250 (6.35)	.500 (12.70)	.500 (12.70)	.500 (12.70)	.625 (15.88)	.625 (15.88)
DA Standard	.312 (7.92)	.500 (12.70)	.500 (12.70)	.500 (12.70)	.812 (20.62)	.812 (20.62)
DA Oversize	.437 (11.10)	.812 (20.62)	.812 (20.62)	.812 (20.62)	1.125 (28.58)	1.125 (28.58)
FA	.125 (3.18)	.375 (9.53)	.375 (9.53)	.375 (9.53)	.625 (15.88)	.625 (15.88)
KA Standard	3/8 – 24	1/2 – 20	1/2 – 20	1/2 – 20	3/4 – 16	3/4 – 16
KA Oversize	1/2 – 20	3/4 – 16	3/4 – 16	3/4 – 16	1 – 14	1 – 14
LD	†2.875 †(73.03)	4.125 (104.78)	4.125 (104.78)	4.250 (107.95)	4.750 (120.65)	4.750 (120.65)
MA Standard	.375 (9.53)	.625 (15.88)	.625 (15.88)	.625 (15.88)	1.000 (25.40)	1.000 (25.40)
MA Oversize	.500 (12.70)	1.000 (25.40)	1.000 (25.40)	1.000 (25.40)	1.375 (34.93)	1.375 (34.93)
P	†1.844 †(46.84)	2.125 (53.98)	2.125 (53.98)	2.250 (57.15)	2.625 (66.68)	2.625 (66.68)
RM Standard	.750 (19.05)	2.000sq (50.80)	2.000 (50.80)	2.000 (50.80)	2.625 (66.68)	2.625 (66.68)
RM Oversize	1.000 (25.40)	2.000sq (50.80)	2.500sq (63.50)	3.000sq(76.20)	3.375 (85.73)	3.375 (85.73)
VA Standard	N/A	.250 (6.35)	.250 (6.35)	.250 (6.35)	.250 (6.35)	.250 (6.35)
VA Oversize	N/A	.500 (12.70)	.500 (12.70)	.500 (12.70)	.375 (9.53)	.375 (9.53)
ZM	4.625 (117.48)	7.000 (177.80)	7.000 (177.80)	7.375 (187.33)	8.500 (215.90)	8.500 (215.90)

Code BD – Double Rod, Tapped (MS4)

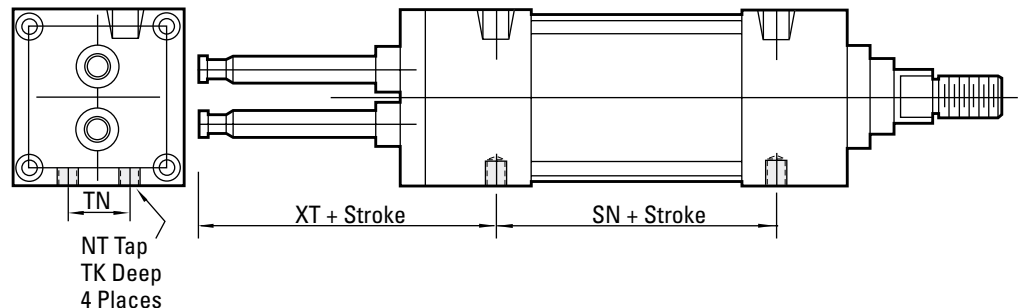

DIMENSION	.1-1/8" BORE (28.58)	.1-1/2" BORE (38.10)	.2" BORE (50.80)	.2-1/2" BORE (63.50)	.3-1/4" BORE (82.55)	.4" BORE (101.60)
NT	10 – 32	1/4 – 20	5/16 – 18	3/8 – 16	1/2 – 13	1/2 – 13
SN	1.875 (47.63)	2.250 (57.15)	2.250 (57.15)	2.375 (60.33)	2.625 (66.68)	2.625 (66.68)
TK	.250 (6.35)	.375 (9.53)	.375 (9.53)	.625 (15.88)	.625 (15.88)	.750 (19.05)
TN	.500 (12.70)	.625 (15.88)	.875 (22.23)	1.250 (31.75)	1.500 (38.10)	2.063 (52.40)
XT	2.000 (50.80)	2.812 (71.42)	2.812 (71.42)	3.063 (77.80)	3.437 (87.30)	3.437 (87.30)

Series BL Mounting Styles and Installation Dimensions

1-1/8" to 4" bore sizes

**Code AD –
Double Rod, Side Lug**

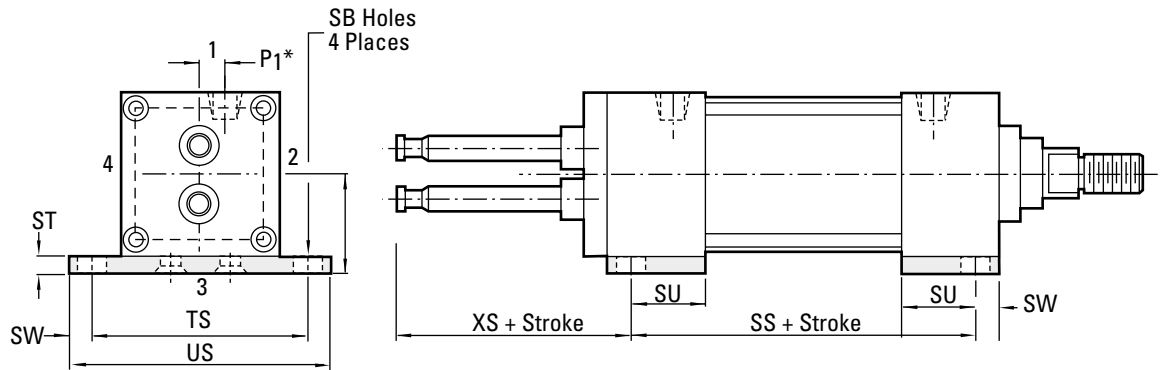

DIMENSION	.1-1/8" BORE (28.58)		.1-1/2" BORE (38.10)		.2" BORE (50.80)		.2-1/2" BORE (63.50)		.3-1/4" BORE (82.55)		.4" BORE (101.60)	
SB	.203	(5.16)	.437	(11.10)	.437	(11.10)	.437	(11.10)	.563	(14.30)	.563	(14.30)
SS	2.250	(57.15)	3.375	(85.73)	3.375	(85.73)	3.500	(88.90)	3.750	(95.25)	3.750	(95.25)
ST	.250	(6.35)	.250	(6.35)	.250	(6.35)	.375	(9.53)	.500	(12.70)	.500	(12.70)
SU	.750	(19.05)	1.125	(28.58)	1.125	(28.58)	1.125	(28.58)	1.250	(31.75)	1.250	(31.75)
SW	.250	(6.35)	.375	(9.53)	.375	(9.53)	.375	(9.53)	.500	(12.70)	.500	(12.70)
TS	1.875	(47.63)	2.750	(69.85)	3.250	(82.55)	3.750	(95.25)	4.750	(120.65)	5.500	(139.70)
US	2.375	(60.33)	3.500	(88.90)	4.000	(101.60)	4.500	(114.30)	5.750	(146.05)	6.500	(165.10)
XS	1.750	(44.50)	2.250	(57.15)	2.250	(57.15)	2.250	(57.15)	2.875	(73.03)	2.875	(73.03)

**Code FD –
Double Rod, Rectangular
Flange (MF1)**

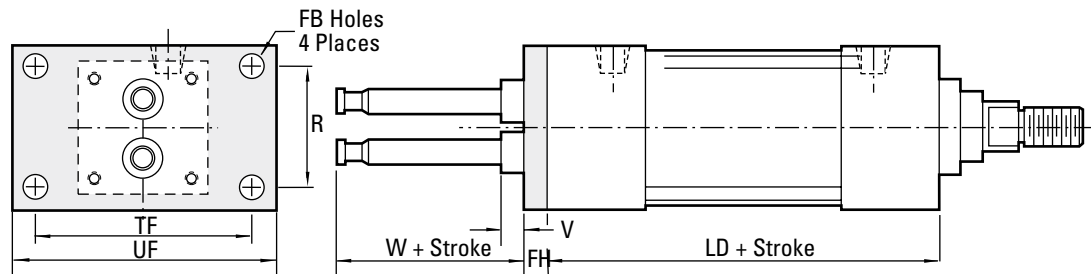

DIMENSION	.1-1/8" BORE (28.58)		.1-1/2" BORE (38.10)		.2" BORE (50.80)		.2-1/2" BORE (63.50)		.3-1/4" BORE (82.55)		.4" BORE (101.60)	
FB	.219	(5.56)	.312	(7.92)	.375	(9.53)	.375	(9.53)	.437	(11.10)	.437	(11.10)
FH	.250	(6.35)	.375	(9.53)	.375	(9.53)	.375	(9.53)	.625	(15.88)	.625	(15.88)
LD	2.875	(73.03)	4.125	(104.78)	4.125	(104.78)	4.250	(107.95)	4.750	(120.65)	4.750	(120.65)
R	1.000	(25.40)	1.430	(36.32)	1.840	(46.74)	2.190	(55.63)	2.760	(70.10)	3.320	(84.33)
TF	2.000	(50.80)	2.750	(69.85)	3.375	(85.73)	3.875	(98.43)	4.688	(119.08)	5.437	(138.10)
TZ	1.250	(31.75)	1.500	(38.10)	2.000	(50.80)	2.500	(63.50)	3.250	(82.55)	4.000	(101.60)
UF	2.500	(63.50)	3.750	(95.25)	4.125	(104.78)	4.625	(117.48)	5.500	(139.70)	6.250	(158.75)
V	N/A		.250	(6.35)	.250	(6.35)	.250	(6.35)	.250	(6.35)	.250	(6.35)
W	1.250	(31.75)	1.500	(38.10)	1.500	(38.10)	1.750	(44.45)	1.750	(44.45)	1.750	(44.45)

Series BL Accessories

1-1/8" to 4" bore sizes

1-1/8" Bore Eye & Clevis Bracket

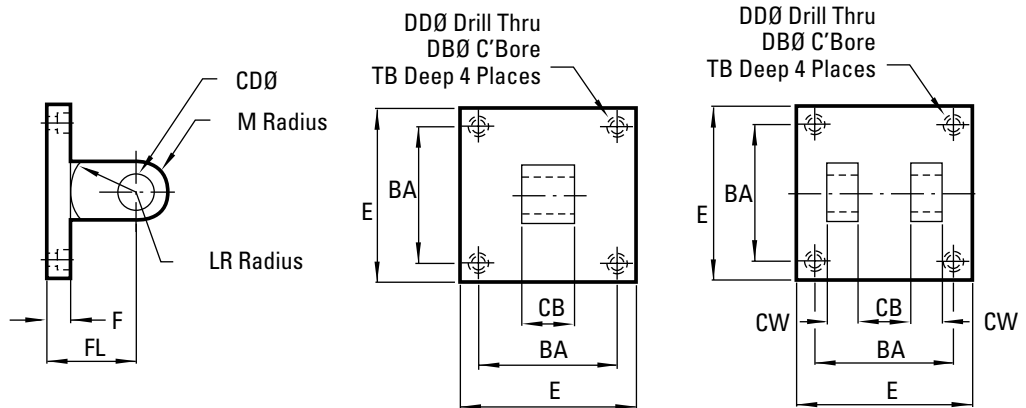

	BL78006A		BL610006A	
BA	1.125	(28.58)	1.150	(29.21)
CB	.375	(9.53)	.375	(9.53)
CD	.375	(9.53)	.375	(9.53)
CW	—		.250	(6.35)
DB	.328	(8.33)	.328	(8.33)
DD	.203	(5.16)	.203	(5.16)
E	1.500	(38.10)	1.500	(38.10)
F	.500	(12.70)	.500	(12.70)
FL	1.125	(28.58)	1.125	(28.58)
LR	.625	(15.88)	.625	(15.88)
M	.375	(9.53)	.375	(9.53)
TB	.312	(7.92)	.312	(7.92)

Rod Eye

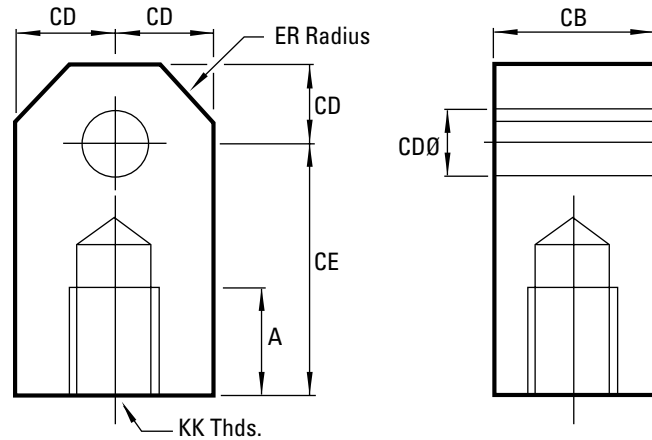

	BL60008C		BL6000CA		BL600010A	
CB	.750	(19.05)	1.250	(31.75)	1.500	(38.10)
CD	.500	(12.70)	.750	(19.05)	1.000	(25.40)
CE	1.500	(38.10)	2.062	(52.37)	2.812	(71.42)
ER	.562	(14.27)	.937	(23.80)	1.125	(28.58)
KK	1/2-20		3/4-16		1-14	

Series BL Accessories

1-1/8" to 4" bore sizes

Rod Clevis

	BL62008B		BL6200CA		BL62010A	
CB	.750	(19.05)	1.250	(31.75)	1.500	(38.10)
CD	.500	(12.70)	.750	(19.05)	1.000	(25.40)
CE	1.500	(38.10)	2.375	(60.33)	3.125	(79.38)
CH	1.000	(25.40)	1.250	(31.75)	1.500	(38.10)
CW	.500	(12.70)	.625	(15.88)	.750	(19.05)
ER	.500	(12.70)	.750	(19.05)	1.000	(25.40)
KK	1/2-20		3/4-16		1-14	
L	.750	(19.05)	1.250	(31.75)	1.500	(38.10)

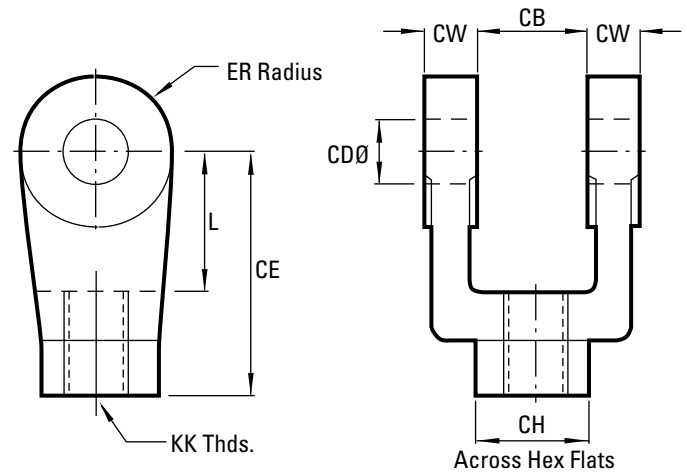

Pilot Adaptor Plate

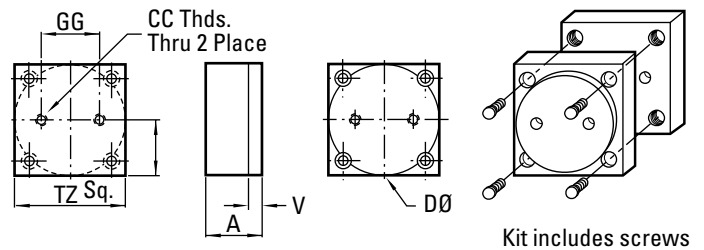

BORE	1-1/8" BL-171-225K		1-1/2" BL-171-03K		2" BL-171-04K		2-1/2" BL-171-05K		3/4" BL-171-065K		4" BL-171-08K	
A	.625	(15.88)	.625	(15.88)	.625	(15.88)	.625	(15.88)	.875	(22.23)	.875	(22.23)
CC	1/4-20	5/16-18	5/16-18	3/8-16	1/2-13	1/2-13						
D	1.260	(32.00)	1.575	(40.01)	1.969	(50.01)	2.480	(62.99)	3.150	(80.01)	3.937	(99.99)
GG	.750	(19.05)	.860	(21.84)	1.180	(29.97)	1.500	(38.10)	1.970	(50.04)	2.760	(70.10)
TZ	1.250	(31.75)	1.500	(38.10)	2.000	(50.80)	2.500	(63.50)	3.250	(82.55)	4.000	(101.60)
V	.160	(4.06)	.160	(4.06)	.200	(5.08)	.200	(5.08)	.200	(5.08)	.200	(5.08)
Y	.625	(15.88)	.750	(19.05)	1.000	(25.40)	1.250	(31.75)	1.625	(41.28)	2.000	(50.80)

Series BL Accessories

1-1/8" to 4" bore sizes

NFPA Pin

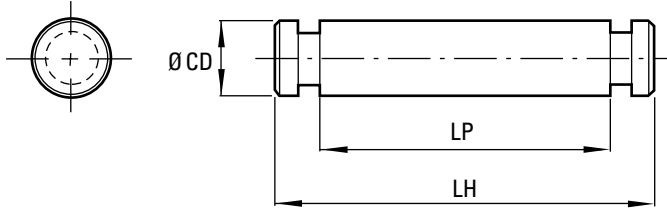

	BL83008A	BL8300CA	BL83010A
CD	.500 (12.70)	.750 (19.05)	1.000 (25.40)
LH	2.219 (56.36)	3.125 (79.38)	3.750 (95.25)
LP	1.875 (47.63)	2.750 (69.85)	3.250 (82.55)

Standard Pin

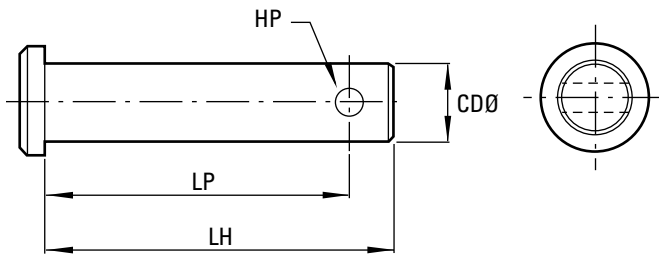

	BL83006C	BL83008C	BL8300CC	BL83010B
CD	.375 (9.53)	.500 (12.70)	.750 (19.05)	1.000 (25.40)
HP	.156 (3.96)	.156 (3.96)	.156 (3.96)	.203 (5.18)
LH	1.250 (31.75)	2.250 (57.15)	3.000 (76.20)	3.500 (88.90)
LP	1.032 (26.21)	2.093 (53.16)	2.843 (72.21)	3.297 (83.74)

Switches

SWITCH MODEL	PS8-2-04 REED	PS8-2-31 HALL	PS8-2-32 HALL	PS7-04 REED	PS7-24 REED	PS7-31 HALL	PS7-32 HALL
Bore Sizes	1-1/8" - 2-1/2"	1-1/8" - 2-1/2"	1-1/8" - 2-1/2"	2" - 4"	2" - 4"	2" - 4"	2" - 4"
Switch Type	Reed Switch *MOV & Light	Hall Effect/Light, Sourcing PNP	Hall Effect/Light, Sinking NPN	Reed Switch *MOV & Light	Reed Switch *MOV & Light, 3 Wire	Hall Effect/Light, Sourcing PNP	Hall Effect/Light, Sinking NPN
Function	SPST NO	Normally Open	Normally Open	Normally Open	Normally Open	Normally Open	Normally Open
Switching Voltage	5-120 VDC/VAC 50/60 Hz	6-24 VDC	6-24 VDC	5-240 VDC/VAC 50/60 Hz	24-240 VAC 50/60 Hz	6-24 VDC	6-24 VDC
Switching Current	.5 Amp Max	.5 Amp Max	.5 Amp Max	1 Amp Max	4 Amp Max 50 Amp Inrush	1 Amp Max	1 Amp Max
Switching Power	10 VA	12 Watts Max	12 Watts Max	30 Watts Max	100 Watts Max	24 Watts Max	24 Watts Max
Max Voltage Drop	3.5 Volts	.5 Volts	.5 Volts	3 Volts	N/A	.5 Volts	.5 Volts
Magnetic Sensitivity	85 Gauss	85 Gauss	85 Gauss	85 Gauss Parallel	85 Gauss Parallel	85 Gauss Parallel	85 Gauss Parallel
Enclosure Class	NEMA 6/CSA	NEMA 6/CSA	NEMA 6/CSA	NEMA 6/CSA	NEMA 6/CSA	NEMA 6/CSA	NEMA 6/CSA
Temperature Range	-22°F to +176°F	-22°F to +176°F	-22°F to +176°F	-22°F to +176°F	-22°F to +176°F	-22°F to +176°F	-22°F to +176°F

Series SL Features / Benefits

A. Piston Seals

Lip-type nitrile seals are pressure energized and wear compensating. Their excellent lubrication retention characteristics lower seal friction and ensure long life.

B. Piston

Solid aluminum alloy, light-weight for low inertia, yet strong.

C. Head/Cap

Precision machined from solid corrosion-resistant 304 stainless steel bar.

D. Rod Wiper

Lip-type urethane aggressively wipes foreign material from piston rod and enhances rod seal life.

E. Rod Seals

Rounded lip-type urethane is pressure energized and wear compensating.

F. Piston Rod

303 stainless steel, 40,000 PSI minimum yield, hard chrome plated, ground and polished.

G. Ultra Cushion®

State-of-the-art design features a unique, one-piece, nitrile compound seal, captured within a precision machined groove. Linear and radial "float" of cushion seal eliminates misalignment. Ultra Cushions provide exceptionally fast "out of cushion" stroke reversal. (Head and Cap Cushions are optional.)

H. Adjustable Captive Cushion Needle

Allows for safe and precise adjustment under pressure.

I. Wear Strip

Teflon® and graphite composition for minimum friction, maximum wear and side load resistance. (Magnetic band under wear strip optional.)

J. Tube

Corrosion-resistant 304 stainless steel.

K. Tie Rods

High-strength 303 stainless steel maintains compression on tube end seals.

L. Retainer

Stainless steel snap ring securely retains bushing in head.

M. Rod Bearings

Machined from 304 stainless steel, with a Teflon® composite wear band insert that eliminates metal-to-metal contact.

N. Acorn Nut

Tie rod threads are covered by stainless steel acorn nuts which eliminate another bacteria hiding place.

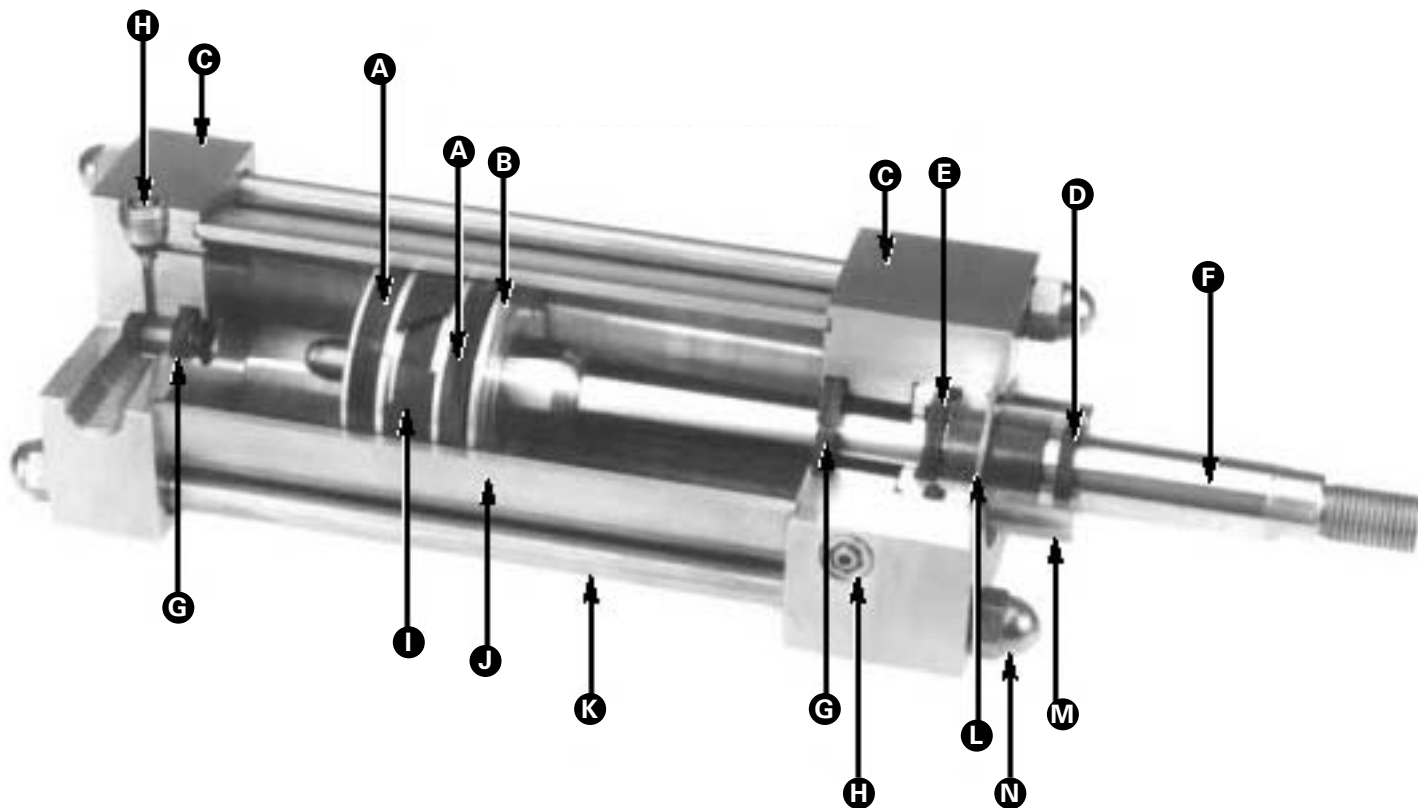

Series SL Model Code

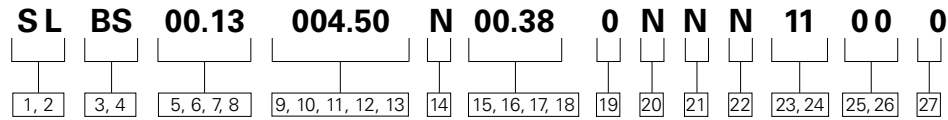

1, 2 Series

SL – Stainless Steel
Pneumatic Cylinders

3, 4 Mounting Styles

1-1/2" thru 8" Bore

- BS** – Side Tapped **MS4**
- FS** – Head Rectangular Flange **MF1**
- GG** – Head Square* **ME3***
- CF** – Cap Fixed Clevis **MP1**
- RS** – Cap Rectangular Flange **MF2**
- PP** – Cap Square* **ME4**
- WS** – Cap Trunnion **MT2**
- US** – Head Trunnion **MT1**
- KS** – No mounts **MX0**
- XX** – Custom
* 8" bore only

1-1/8" Bore

- KS** – No mounts **MX0**
- EE** – Bolt Thru **MS8**
- RS** – Cap Rectangular Flange **MF2**
- CM** – Fixed Eye **MP3**
- BS** – Tapped **MS9**
- FM** – Head Tapped Face **MR1**
- KD** – Double Rod, No Mounts **MX0**

5, 6, 7, 8 Bore

Specify in inches
(2 position decimal)

- 01.13 – 1-1/8"
- 01.50 – 1-1/2"
- 02.00 – 2"
- 02.50 – 2-1/2"
- 03.25 – 3-1/4"
- 04.00 – 4"
- 05.00 – 5"
- 06.00 – 6"
- 08.00 – 8"

9, 10, 11, 12, 13 Stroke

Specify length in inches
(3 positions to the left of decimal and 2 positions to the right)

Code Bore

9, 10, 11, 12, 13 Stroke

Specify length in inches
(3 positions to the left of decimal and 2 positions to the right) For example:

Code	Size
004.50	4.50
010.00	10
112.50	112.50

14 Cushions

Cushions are located as shown below when viewing cylinder from head end (mounting end of double rod cylinders). "--" in table indicates no cushion.

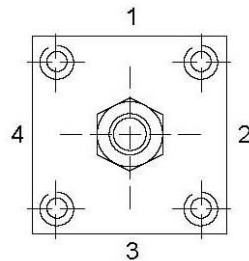

Code	Head	Cap
N	–	–
C	–	2
H	2	–
B	2	2
A	1	–
D	3	–
E	4	–
F	–	1
G	–	3
J	–	4

15, 16, 17, 18 Rod Diameter

Specify in inches
(2 position decimal)

- 00.38 – 3/8" Rod Dia.
- 00.63 – 5/8" Rod Dia.
- 00.50 – 1/2" Rod Dia.
- 01.00 – 1" Rod Dia.
- 01.38 – 1-3/8" Rod Dia.
- 01.75 – 1-3/4" Rod Dia.

19 Rod End Types

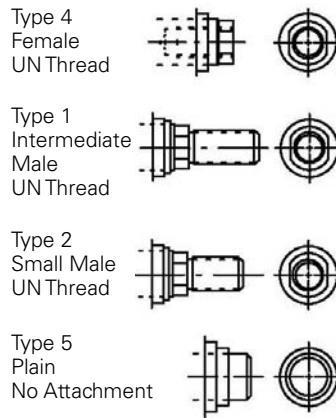

20 Ports

Code	Port Style
N	Standard
L	Oversized (NFPA)

21 Rod Seals

N – Standard (Nitrile)

22 Piston Seals

N – Standard (Nitrile)

23, 24 Port Locations

Code	Head	Cap
11	1	1
22	2	2
33	3	3
44	4	4

25, 26 Special Modifications

Extra Rod Projection
Item 25 indicates inches from 0 thru 9. Item 26 indicates fraction of an inch per the following codes:

Code	Fraction	Code	Fraction
0	0	8	1/2
1	1/16	9	9/16
2	1/8	A	5/8
3	3/16	B	11/16
4	1/4	C	3/4
5	5/16	D	13/16
6	3/8	E	7/8
7	7/16	F	15/16

– OR –

PK – Magnet Furnished to operate Hall Effect or Read Type Switch

27 Custom

X – Custom Modification

Series SL

Mounting Styles:

1-1/2" – 8" Bore

Available Mountings

The variety of standard NFPA mountings available in the 1 1/2"-8" bore Series SL gives you a broad selection to match the proper mount to your application. Eaton offers rigid mounts (including flange mounts) and swivel mounts (including clevis mounts). A guide to proper mount selection is provided on pages 122 through 126. For custom mounts, enter "XX" for model code positions 3 and 4, and give a detailed description with drawings. Series SL cylinders are available in all mounting styles listed.

Selecting the Proper Mounting

Just as the cylinder bore must be sized to provide the proper force for an application, a cylinder mounting that can absorb these application forces must also be specified. Note: In the mounting information, some mounts have been down-rated to minimize deflection. For applications where the motion is linear and parallel to the cylinder rod motion, a rigid mount is recommended. For curvilinear motion, a swivel mount should be chosen. The specifics of each application dictate the correct mounting style.

Code BS (MS4)
Side Tap

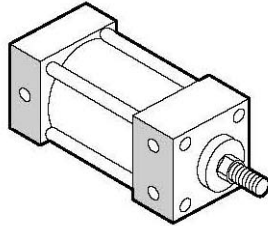

Code FS (MF1)
Head Rectangular Flange

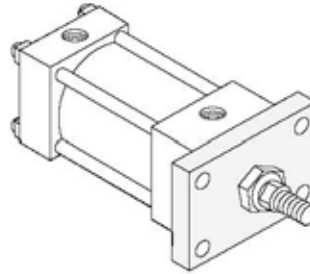

Code GG (ME3)
Head Square

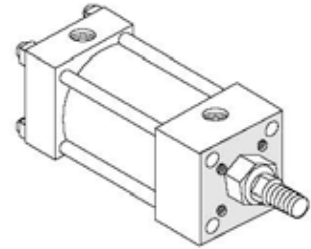

Code CF (MP1)
Cap Fixed Clevis

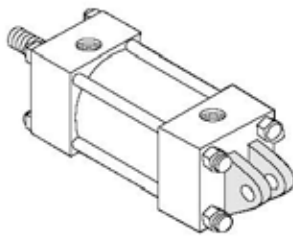

Code RS (MF2)
Cap Rectangular Flange

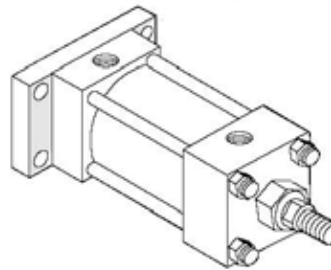

Code PP (ME4)
Cap Square

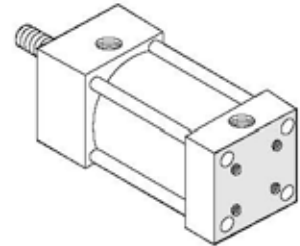

Code WS (MT2)
Cap Trunnion

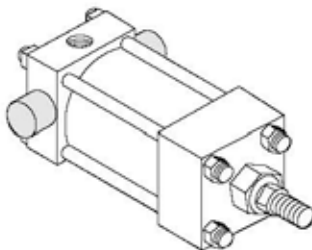

Code US (MT2)
Head Trunnion

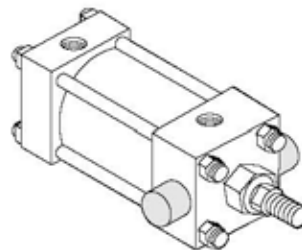

Code KS (MX0)
No Mounts

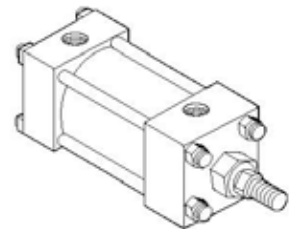

Series SL

Mounting Styles:

1-1/8" Bore

Available Mountings

The variety of standard NFPA mountings available in the 1 1/8" bore Series SL gives you a broad selection to match the proper mount to your application. Eaton offers rigid mounts (including bolt-thru mounts and flange mounts). A guide to proper mount selection is provided on pages 122 through 126. For custom mounts, enter "XX" for model code positions 3 and 4, and give a detailed description with drawings. Series SL cylinders are available in all mounting styles listed.

Selecting the Proper Mounting

Just as the cylinder bore must be sized to provide the proper force for an application, a cylinder mounting that can absorb these application forces must also be specified. Note: In the mounting information, some mounts have been down-rated to minimize deflection. For applications where the motion is linear and parallel to the cylinder rod motion, a rigid mount is recommended. For curvilinear motion, a swivel mount should be chosen. The specifics of each application dictate the correct mounting style.

Code KS (MX0)
No Mounts

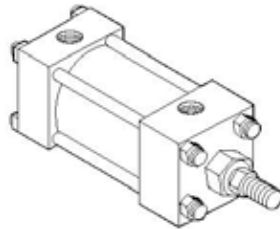

Code AS (MS8)
Bolt Thru

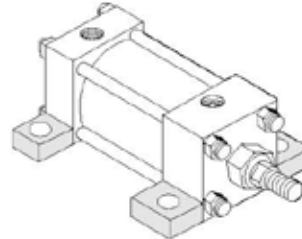

Code BS (MS9)
Tapped

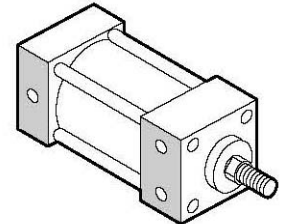

Code RS (MF2)
Cap Rectangular Flange

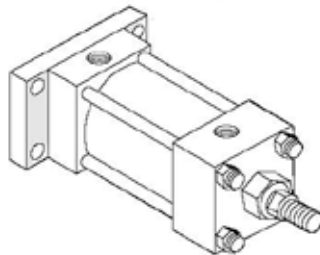

Code FM (MR1)
Head Tapped Face

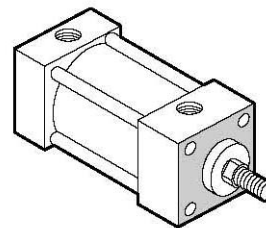

Code KD (MX0)
Double Rod, No Mounts

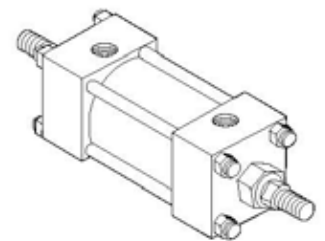

Code CM (MP3)
Fixed Eye

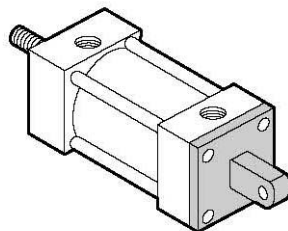

Series SL Standard Cylinder

1-1/8" to 8" bore

Standard Cylinder Dimensions

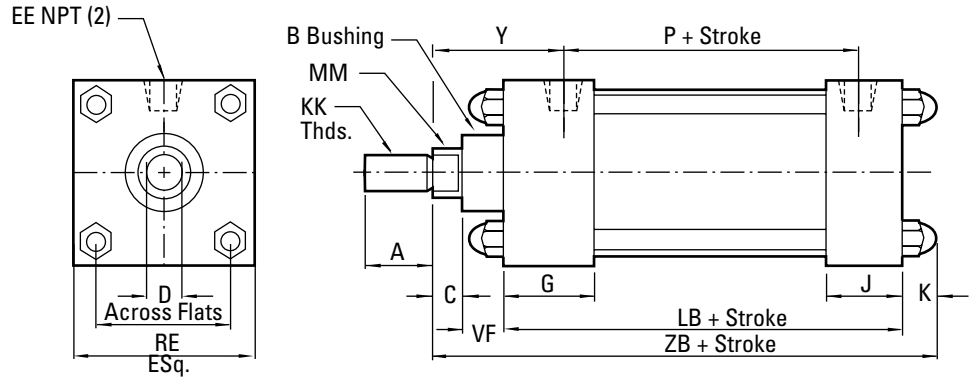

BORE		1-1/8"	1-1/2"	2"	2-1/2"	3-1/4"	4"	5"	6"	8"
ø Rod (MM)	Std.	3/8"	5/8"	5/8"	5/8"	1"	1"	1"	1-3/8"	1-3/8"
	O.S.	1/2"	1"	1"	1"	1-3/8"	1-3/8"	1-3/8"	1-3/4"	1-3/4"
A	Std.	.625	0.75	0.75	0.75	1.125	1.125	1.125	1.625	1.625
	O.S.	.750	1.125	1.125	1.125	1.625	1.625	1.625	2.000	2.000
B +.000 -.002	Std.		1.125	1.125	1.125	1.500	1.500	1.500	2.000	2.000
	O.S.		1.500	1.500	1.500	2.000	2.000	2.000	2.375	2.375
C	Std.	.25	0.375	0.375	0.375	0.5	0.5	0.5	0.625	0.625
	O.S.	-	0.5	0.5	0.5	0.625	0.625	0.625	0.75	0.75
D	Std.	.312	0.5	0.5	0.5	0.812	0.812	0.812	1.125	1.125
	O.S.	.437	0.812	0.812	0.812	1.125	1.125	1.125	1.5	1.5
E		1.5	2	2.5	3	3.75	4.5	5.5	6.5	8.5
EE	Std.	.125	0.25	0.25	0.25	0.375	0.375	0.375	0.5	0.5
	O.S.	-	0.375	0.375	0.375	0.5	0.5	0.5	0.75	0.75
G		.875	1.5	1.5	1.5	1.75	1.75	1.75	2	2
J		.625	1	1	1	1.25	1.25	1.5	1.5	1.5
K		.400	0.469	0.531	0.531	0.625	0.625	0.83	0.83	1
KK	Std.	5/16-24	1/2 - 20	1/2 - 20	1/2 - 20	3/4 - 16	3/4 - 16	3/4 - 16	1 - 14	1 - 14
	O.S.	7/16-20	3/4 - 16	3/4 - 16	3/4 - 16	1 - 14	1 - 14	1 - 14	1-1/4 - 12	1-1/4 - 12
LB		2.25	3.625	3.625	3.75	4.25	4.25	4.5	5	5.125
P		1.375	2.125	2.125	2.25	2.625	2.625	2.875	3	3.125
RE		.750	1.43	1.84	2.19	2.76	3.32	4.1	4.88	6.435
VF	Std.	.125	0.625	0.625	0.625	0.875	0.875	0.875	1	1
	O.S.	-	0.875	0.875	0.875	1	1	1	1.125	1.125
Y	Std.	.938	2	2	2	2.437	2.437	2.437	2.875	2.875
	O.S.	-	2.375	2.375	2.375	2.687	2.687	2.687	3.125	3.125
ZB	Std.	2.625	5.094	5.156	5.281	6.25	6.25	6.705	7.455	7.75
	O.S.	-	5.469	5.531	5.656	6.5	6.5	6.955	7.705	8

Dimensions in inches (mm)

Series SL Mounting Styles and Installation Dimensions

1-1/2" to 8" bore sizes

Code BS – Side Tapped (MS4)

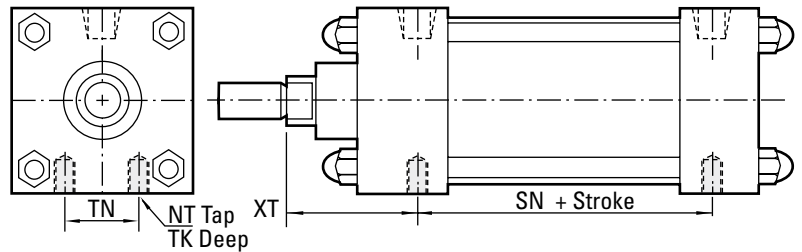

BORE	1-1/2"	2"	2-1/2"	3-1/4"	4"	5"	6"	8"
NT	1/4-20	5/16-18	3/8-16	1/2-13	1/2-13	5/8-11	3/4-10	3/4-10
SN	2.250	2.250	2.375	2.625	2.625	2.875	3.125	3.250
TK	.375	.500	.625	.750	.750	1.000	1.125	1.125
TN	.625	.875	1.250	1.500	2.062	2.687	3.250	4.500
XT Std.	1.937	1.937	1.937	2.437	2.437	2.437	2.812	2.812
O.S.	2.312	2.312	2.312	2.687	2.687	2.687	3.062	3.062

Dimensions in inches (mm)

Code FS – Head Rectangular Flange (MF1)

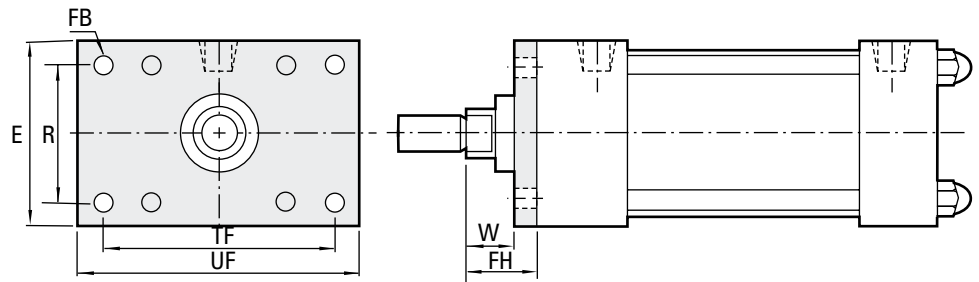

BORE	1-1/2"	2"	2-1/2"	3-1/4"	4"	5"	6"
E	2.000	2.500	3.000	3.750	4.500	5.500	6.500
FB	.312	.375	.375	.437	.437	.562	.562
G	1.500	1.500	1.500	1.750	1.750	1.750	2.000
FH	.375	.375	.375	.625	.625	.625	.750
R	1.430	1.840	2.190	2.760	3.320	4.100	4.880
TF	2.750	3.375	3.875	4.687	5.437	6.625	7.625
UF	3.375	4.125	4.625	5.500	6.250	7.625	8.625
W Std.	.625	.625	.625	.750	.750	.750	.875
O.S.	1.000	1.000	1.000	1.000	1.000	1.000	1.125

Dimensions in inches (mm)

Code GG – Head Square Mount (ME3)

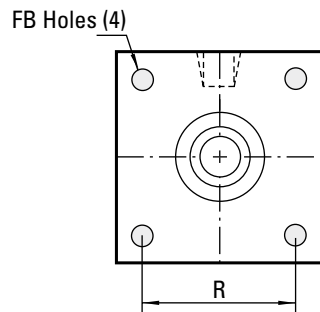

BORE	8"
FB	.687
R	7.570

Dimensions in inch (mm)

Series SL Mounting Styles and Installation Dimensions

1-1/2" to 8" bore sizes

Code CF – Cap Fixed Clevis (MP1)

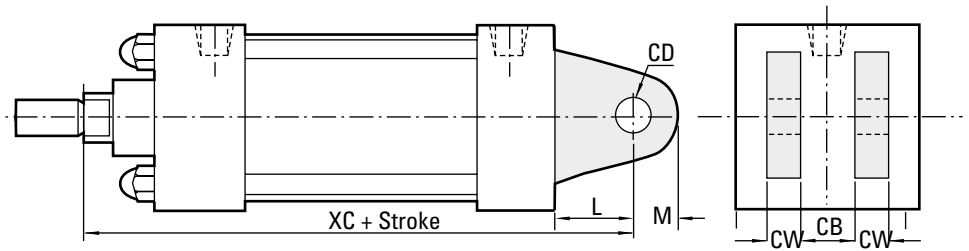

BORE	1-1/2"	2"	2-1/2"	3-1/4"	4"	5"	6"	8"
CB	.750	.750	.750	1.250	1.250	1.250	1.500	1.500
CD	.500	.500	.500	.750	.750	.750	1.000	1.000
CW	.500	.500	.500	.625	.625	.625	.750	.750
L	.750	.750	.750	1.250	1.250	1.250	1.500	1.500
M	.625	.625	.625	.875	.875	.875	1.000	1.000
XC Std.	5.375	5.375	5.500	6.875	6.875	7.125	8.125	8.250
O.S.	5.750	5.750	5.875	7.125	7.125	7.375	8.375	8.500

Dimensions in inches (mm)

Code RS – Rectangular Flange (MF2)

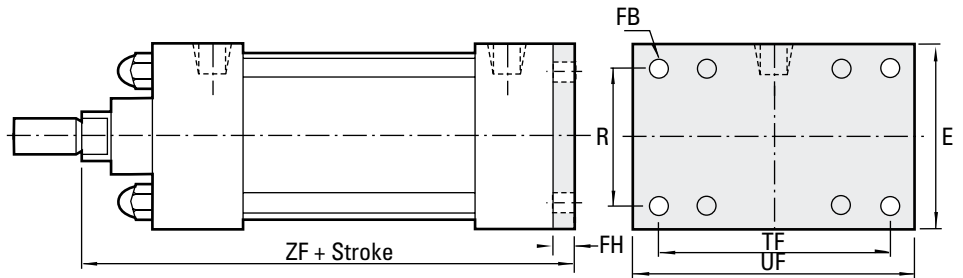

BORE	1-1/2"	2"	2-1/2"	3-1/4"	4"	5"	6"
E	2.000	2.500	3.000	3.750	4.500	5.500	6.500
FB	.312	.375	.375	.437	.437	.562	.562
G	1.500	1.500	1.500	1.750	1.750	1.750	2.000
FH	.375	.375	.375	.625	.625	.625	.750
R	1.430	1.840	2.190	2.760	3.320	4.100	4.880
TF	2.750	3.375	3.875	4.687	5.437	6.625	7.625
UF	3.375	4.125	4.625	5.500	6.250	7.625	8.625
W Std.	.625	.625	.625	.750	.750	.750	.875
O.S.	1.000	1.000	1.000	1.000	1.000	1.000	1.125
ZF Std.	5.000	5.000	5.125	6.250	6.250	6.500	7.375
O.S.	5.375	5.375	5.500	6.500	6.500	6.750	7.625

Dimensions in inches (mm)

Series SL Mounting Styles and Installation Dimensions

1-1/2" to 8" bore sizes

Code PP – Cap Square (ME4)

BORE	8"
FB	.687
R	7.570

Dimensions in inches (mm)

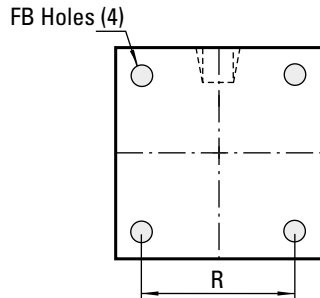

Code US – Head Trunnion (MT1)

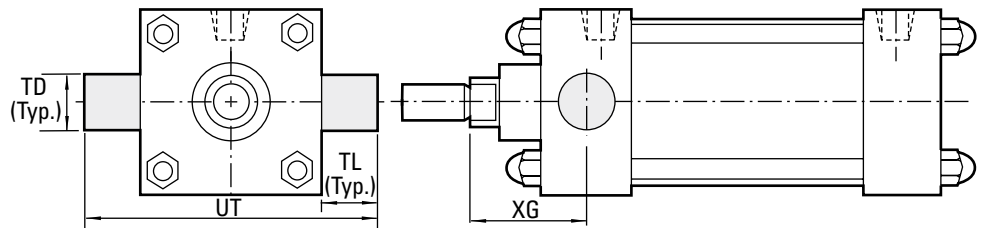

BORE	1-1/2"	2"	2-1/2"	3-1/4"	4"	5"	6"	8"
TD	1.000	1.000	1.000	1.000	1.000	1.000	1.375	1.375
TL	1.000	1.000	1.000	1.000	1.000	1.000	1.375	1.375
UT	4.000	4.500	5.000	5.750	6.500	7.500	9.250	11.250
XG Std.	1.750	1.750	1.750	2.250	2.250	2.250	2.625	2.625
O.S.	2.125	2.125	2.125	2.500	2.500	2.500	2.875	2.875

Dimensions in inches (mm)

Code WS – Cap Trunnion (MT2)

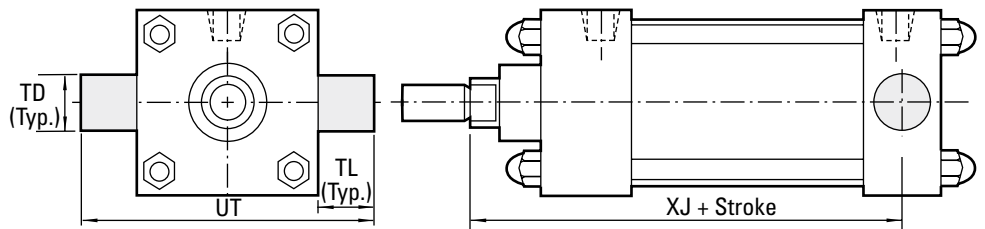

BORE	1-1/2"	2"	2-1/2"	3-1/4"	4"	5"	6"	8"
TD	1.000	1.000	1.000	1.000	1.000	1.000	1.375	1.375
TL	1.000	1.000	1.000	1.000	1.000	1.000	1.375	1.375
UT	4.000	4.500	5.000	5.750	6.500	7.500	9.250	11.250
XJ Std.	4.125	4.125	4.250	5.000	5.000	5.250	5.875	6.000
O.S.	4.500	4.500	4.625	5.250	5.250	5.500	6.125	6.250

Dimensions in inches (mm)

Series SL Mounting Styles and Installation Dimensions

1-1/8" bore

Code AS – Bolt Thru (MS8)

BOLT THRU

DB	.203
DN	1.000
SB	#10
SD	1.750
XB	.625

Dimensions in inches (mm)

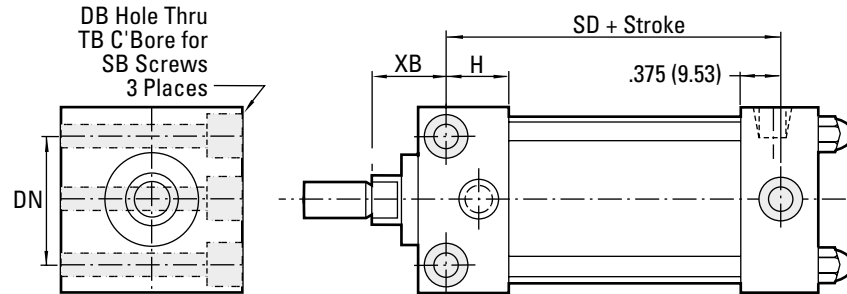

Code BS – Tapped (MS9)

SIDE TAP

NT	10-32
SN	1.750
TK deep	.250
TN	1.000
XT	.625

Dimensions in inches (mm)

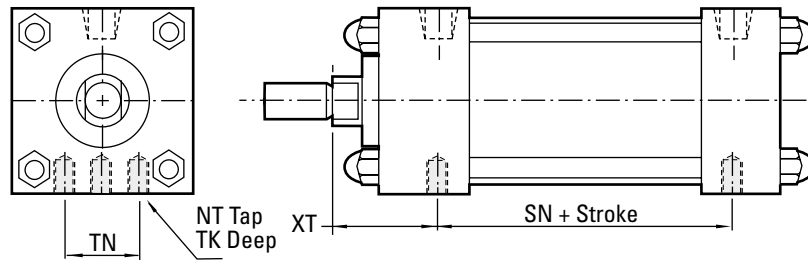

Code RS – Cap Rectangular Flange (MF2)

REAR FLANGE

E	1.500
FB	.219
FH	.250
R	1.000
TF	2.000
UF	2.500
ZF	2.875

Dimensions in inches (mm)

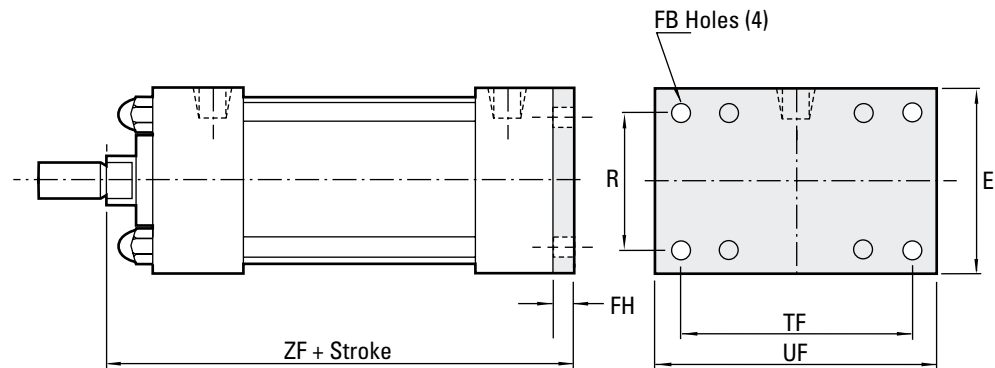

Series SL Mounting Styles and Installation Dimensions

1-1/8" bore

Code FM – Head Tapped Face (MR1)

30 (MR1) HEAD FACE

BC	1.593
RE	1.125
RT	10-32

Dimensions in inches (mm)

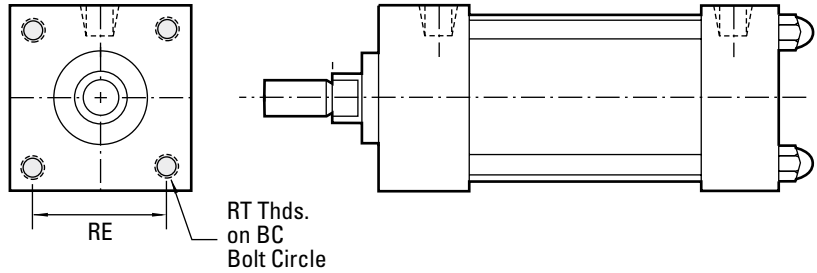

Code KD – Double Rod, No Mounts (MX0)

DOUBLE ROD END CYLINDER WITH 01 (MX0) BASIC

D	Std.	.312
O	.S.	.437
E		1.500
EE		.125
G		.875
K		.400
LB		2.250
MM	Std.	.370
	O.S.	.495
P		1.375
RM	Std.	.750
	O.S.	1.000
Y		.938
ZB		3.250

Dimensions in inches (mm)

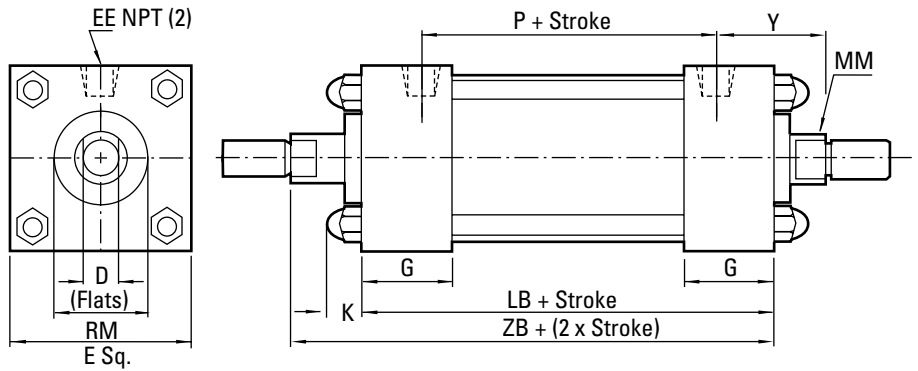

Code CM – Fixed Eye (MP3)

17 (MP3) FIXED EYE

CB	.375
CD	.375
L	.437
M	.375
XC	3.062

Dimensions in inches (mm)

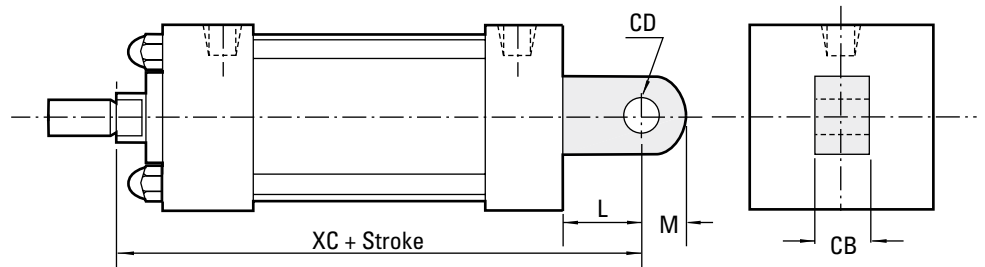

Series SL Rod End Types

Standard & Optional Rod Ends

Type 2: Small Male UN Thread

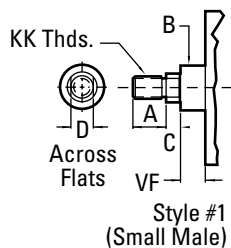

Type 4: Female UN Thread

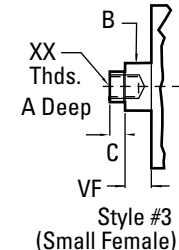

Type 1: Intermediate Male UN Thread

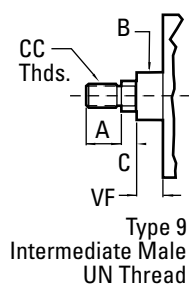

BORE		1-1/8"	1-1/2"	2"	2-1/2"	3-1/4"	4"	5"	6"	8"
∅ Rod	Std.	3/8"	5/8"	5/8"	5/8"	1"	1"	1"	1-3/8"	1-3/8"
(MM)	O.S.	1/2"	1"	1"	1"	1-3/8"	1-3/8"	1-3/8"	1-3/4"	1-3/4"
A	Std.	.625	0.750	0.750	0.750	1.125	1.125	1.125	1.625	1.625
	O.S.	.750	1.125	1.125	1.125	1.625	1.625	1.625	2.000	2.000
B +.000	Std.	—	1.125	1.125	1.125	1.500	1.500	1.500	2.000	2.000
-.002	O.S.	—	1.500	1.500	1.500	2.000	2.000	2.000	2.375	2.375
C	Std.	.250	0.375	0.375	0.375	0.500	0.500	0.500	0.625	0.625
	O.S.	—	0.500	0.500	0.500	0.625	0.625	0.625	0.750	0.750
CC	Std.	3/8 – 24	7/16 – 20	7/16 – 20	7/16 – 20	7/8 – 14	7/8 – 14	7/8 – 14	1-1/4 – 12	1-1/4 – 12
	O.S.	1/2 – 20	7/8 – 14	7/8 – 14	7/8 – 14	1-1/4 – 12	1-1/4 – 12	1-1/4 – 12	1-1/2 – 12	1-1/2 – 12
D	Std.	.312	0.500	0.500	0.500	0.812	0.812	0.812	1.125	1.125
	O.S.	.437	0.812	0.812	0.812	1.125	1.125	1.125	1.500	1.500
E			2	2.5	3	3.750	4.500	5.500	6.500	8.500
EE	Std.		0.250	0.250	0.250	0.375	0.375	0.375	0.500	0.500
	O.S.		0.375	0.375	0.375	0.500	0.500	0.500	0.750	0.750
FF	Std.		5/8 – 18	5/8 – 18	5/8 – 18	1 – 14	1 – 14	1 – 14	1-3/8 – 12	1-3/8 – 12
	O.S.		1 – 14	1 – 14	1 – 14	1-3/8 – 12	1-3/8 – 12	1-3/8 – 12	1-3/4 – 12	1-3/4 – 12
G			1.500	1.500	1.500	1.750	1.750	1.750	2	2
J			1	1	1	1.250	1.250	1.500	1.500	1.500
K			0.469	0.531	0.531	0.625	0.625	0.830	0.830	1
KK	Std.		1/2 – 20	1/2 – 20	1/2 – 20	3/4 – 16	3/4 – 16	3/4 – 16	1 – 14	1 – 14
	O.S.		3/4 – 16	3/4 – 16	3/4 – 16	1 – 14	1 – 14	1 – 14	1-1/4 – 12	1-1/4 – 12
LB			3.625	3.625	3.750	4.250	4.250	4.50	5	5.125
P			2.125	2.125	2.250	2.625	2.625	2.875	3	3.125
RE			1.430	1.840	2.190	2.760	3.320	4.100	4.880	6.435
VF	Std.	.125	0.625	0.625	0.625	0.875	0.875	0.875	1	1
	O.S.	—	0.875	0.875	0.875	1	1	1	1.125	1.125
XX	Std.	1/4 – 28	7/16 – 20	7/16 – 20	7/16 – 20	3/4 – 16	3/4 – 16	3/4 – 16	1 – 14	1 – 14
	O.S.	3/8 – 24	3/4 – 16	3/4 – 16	3/4 – 16	1 – 14	1 – 14	1 – 14	1-1/4 – 12	1-1/4 – 12
Y	Std.		2.000	2	2	2.437	2.437	2.437	2.875	2.875
	O.S.		2.375	2.375	2.375	2.687	2.687	2.687	3.125	3.125
ZB	Std.		5.094	5.156	5.281	6.250	6.250	6.705	7.455	7.750
	O.S.		5.469	5.531	5.656	6.500	6.500	6.955	7.705	8

Dimensions in inches (mm)

Accessories for SL Cylinders

1-1/2" to 8" bore sizes

Rod Clevis 303 Stainless Steel

	SL62008A	SL6200CA	SL62010A	SL62016A
CB	.750	1.250	1.500	2.000
CD	.500	.750	1.000	1.375
CE	1.500	2.375	3.125	4.125
CH	1.000	1.250	1.500	2.000
CW	.500	.625	.750	1.000
ER	.500	.750	1.000	1.375
KK	1/2-20	3/4-16	1-14	1-1/4 - 12
L	.750	1.250	1.500	2.125

Dimensions in inches (mm)

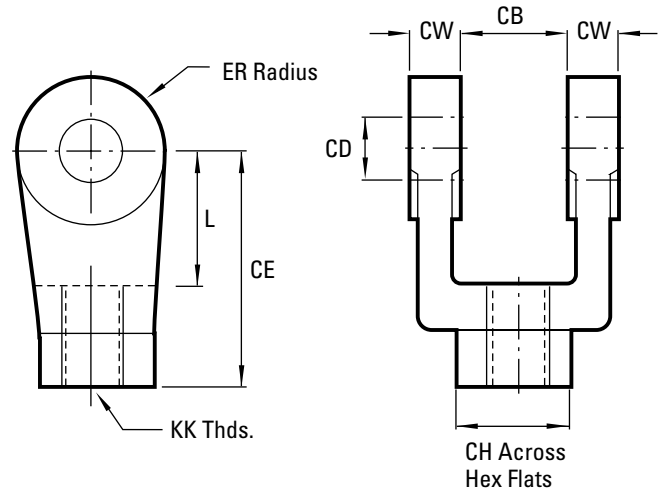

NFPA Pin 303 Stainless Steel

	SL83008A	SL8300CA	SL83010A	SL83016A
CD	.500	.750	1.000	1.375
LH	2.219	3.125	3.750	5.625
LP	1.875	2.750	3.250	4.375

Dimensions in inches (mm)

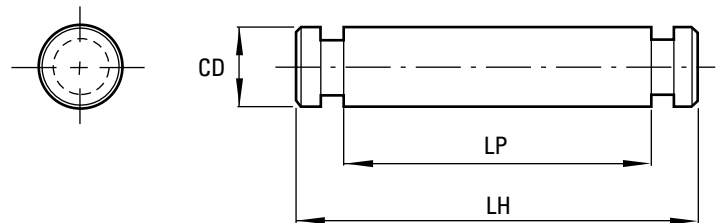

Accessories for SL Cylinders

1-1/2" to 8" bore sizes

Rod Alignment Coupler

	SL7756A- 7/16-20	SL7756A- 1/2-20	SL7756A- 3/4-16	SL7756A- 1-14
A	7/16-20	1/2 - 20	3/4 - 16	1-14
B	1.250	1.250	1.750	2.500
C	2.000	2.000	2.312	2.937
D	.500	.500	.500	.500
E	.750	.750	1.125	1.625
F	.625	.625	.969	1.375
G	.563	.563	.812	1.156
H	1.125	1.125	1.500	2.250
Max Pull (lbs)	2.250	3.150	7.750	12.250

Made of 303 Stainless Steel, the Rod Alignment Coupler allows 1/16" of radial float and 2° of spherical movement.

Dimensions in inches (mm)

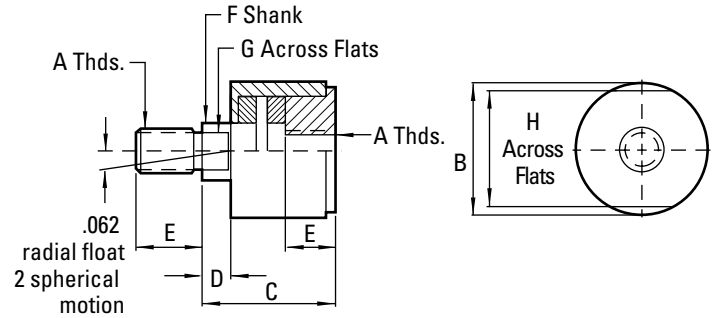

Eye Bracket 303 Stainless Steel

	SL78008A	SL7800CA	SL78010A
BA	1.625	2.562	3.250
CB	.750	1.250	1.500
CD	.500	.750	1.000
DD	.406	.531	.656
E	2.500	3.500	4.500
F	.375	.625	.750
FL	1.125	1.875	2.250
LR	.750	1.250	1.500
M	.500	.750	1.000

Dimensions in inches (mm)

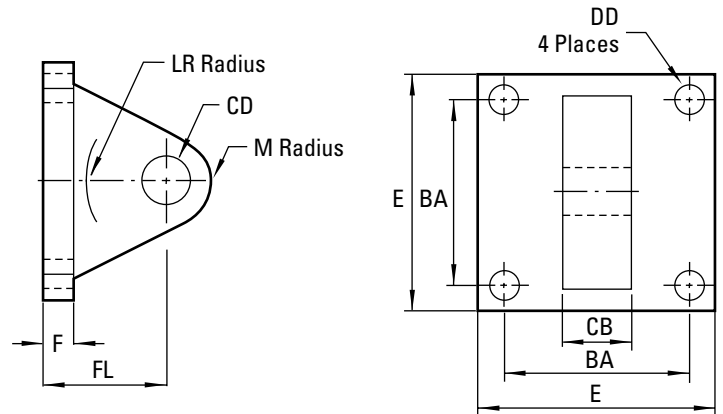

Accessories for SL Cylinders

1-1/8" bore

Rod eye 303 stainless steel w/jam nut

	SL60006A*	SL60006B**
A	.437	.437
CA	.875	.875
CB	.375	.375
CD	.375	.375
ER	.375	.375
H	.750	.750
KK	3/8-24	1/2-20
N	.219	.312

* Includes jam nut (3/8-24)
** Includes jam nut (1/2-20)
Dimensions in inches (mm)

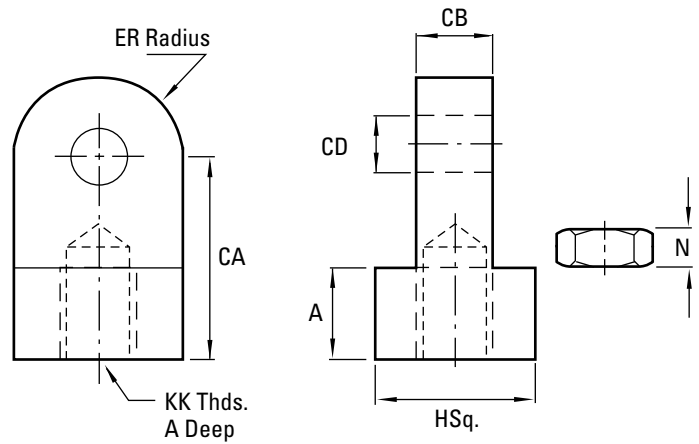

Pivot pin 303 stainless steel

PIVOT PIN	SL83006A
CD	.375
LH	1.250
LP	1.032

Dimensions in inches (mm)

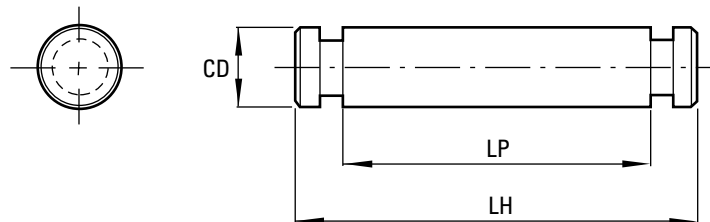

Accessories for SL Cylinders

1-1/8" bore

Clevis bracket 304 stainless steel

SL61006A	
BA	1.125
CB	.375
CD	.375
CW	.250
DB	.328
DD	.203
E	1.50
F	.500
FL	1.125
LR	.625
M	.375
TB	.260

Dimensions in inches (mm)

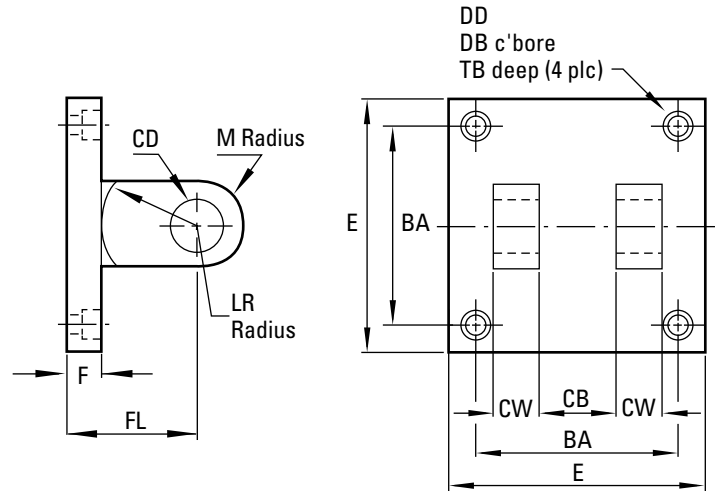

NFPA Rod alignment coupler

SL7756A-3/8-24	
A	3/8 - 24
B	.875
C	1.250
D	.250
E	.625
F	.375
G	.312
H	.750
Maximum pull	1,375

Dimensions in inches (mm)

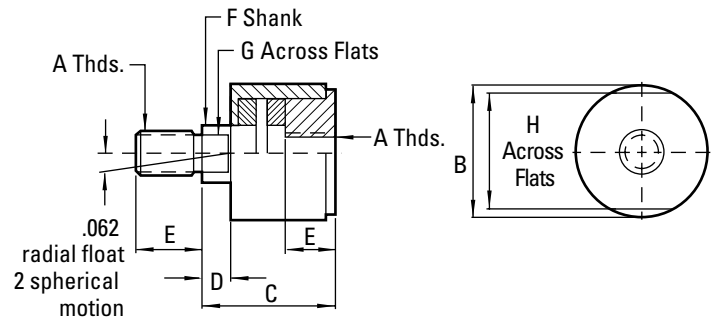

Made of 303 Stainless Steel, the Rod Alignment Coupler allows 1/16" of radial float and 2° of spherical movement.

This prevents cylinder binding due to misalignment thus extending bearing and seal life, and permits greater tolerance between the center line of the cylinder and mating part for simplified installation.

Series SL Technical Information

Operating Temperatures

Series SS -40°F to 200°F
(-40°C to 93°C)

Operating Pressure

250 psig Air (17.2 Bar)
400 psig Hydraulic (27.6 Bar)
Bore Sizes: 1-1/8", 1-1/2", 2",
2-1/2", 3-1/4", 4", 5", 6", 8"

Lubrication

None required
Eaton's Hydro-Line®
pneumatic cylinders are
rated for "no lube added"
service. All internal compo-
nents are lubricated at time
of assembly with a Teflon®
based grease.

Materials

Head and End Caps: 304
stainless steel
Tube: 304 stainless steel
Piston Rod: hard chrome
plated 303 stainless steel
Piston: 2011-T451 aluminum
with Teflon® composite
wearband
Rod Bearings: 304 stainless
steel with Teflon® composite
wearband
Seals: urethane rod seal and
wiper, nitrile piston seals
Tie Rods: 303 stainless steel

Side Loading

Cylinders are specifically
designed to push and pull.
Side loading of the piston rod
should be avoided to ensure
maximum operating perfor-
mance and life.
Care should be taken dur-
ing installation to properly
align the load to be moved
with the center line of the
cylinder. The use of a rod
alignment coupler is strongly
recommended whenever
possible.

Cylinder Weights

In pounds (kilograms)

BORE	ROD	KS, BS, EE, GG, PP, FM	FS & RS	MOUNTING CODE		ADD PER INCH OF STROKE
				*CF & CM	US, WS	
1-1/8"	3/8"	1.1 (.49)	1.5 (.68)	1.3 (.58)	– –	.13 (.05)
	1/2"	1.2 (.54)	1.6 (.72)	1.4 (.63)	– –	.15 (.06)
1-1/2"	5/8"	3.3 (1.49)	4.0 (1.81)	3.8 (1.72)	3.8 (1.72)	.3 (.13)
	1"	4.1 (1.85)	4.8 (2.17)	4.6 (2.08)	4.6 (2.08)	.4 (.18)
2"	5/8"	5.9 (2.67)	7.0 (3.17)	6.4 (2.90)	6.4 (2.90)	.5 (.22)
	1"	6.3 (2.85)	7.4 (3.35)	6.8 (2.94)	6.8 (3.08)	.6 (.27)
2-1/2"	5/8"	8.0 (3.62)	9.5 (4.30)	8.7 (3.94)	8.5 (3.85)	.6 (.27)
	1"	8.5 (3.85)	10.0 (4.53)	9.2 (4.17)	9.0 (4.08)	.7 (.31)
3 1/4"	1"	15.0 (6.80)	18.7 (8.48)	16.0 (7.25)	15.5 (7.03)	.8 (.36)
	1 3/8"	15.5 (7.03)	19.2 (8.70)	16.5 (7.48)	16.0 (7.25)	1.0 (.45)
4"	1"	23.0 (10.43)	28.0 (12.70)	27.0 (12.24)	23.5 (10.65)	1.0 (.45)
	1 3/8"	23.5 (10.65)	28.5 (12.92)	27.5 (12.47)	24.0 (10.88)	1.2 (.54)
5"	1"	34.5 (15.64)	42.0 (19.05)	41.0 (18.59)	35.0 (15.87)	1.1 (.49)
	1 3/8"	35.0 (15.87)	42.5 (19.27)	41.5 (18.82)	35.5 (16.10)	1.3 (.58)
6"	1 3/8"	60.0 (27.21)	71.9 (32.61)	69.0 (31.29)	61.2 (27.76)	1.5 (.68)
	1 3/4"	62.0 (28.12)	73.9 (33.52)	71.0 (32.20)	63.2 (28.66)	1.7 (.77)
8"	1 3/8"	79.0 (35.83)	– –	88.0 (39.91)	80.2 (36.37)	2.0 (.90)
	1 3/4"	82.0 (37.19)	– –	91.0 (41.27)	83.2 (37.73)	2.3 (1.04)

*Weight includes pivot pin

Series SL Technical Information

Piston Rod Diameter Selection

Applications requiring long extend (push) strokes may require oversize piston rod diameters to prevent buckling. To determine the correct rod diameter for your application follow these simple steps:

1. Select the thrust from the **Cylinder Force and Volume Chart** that is required for your application.

$$\text{Thrust} = \text{Piston Surface Area} \times \text{Operating Pressure}$$

2. From the **Cylinder Mounting Diagrams** select the mounting style being used.
3. With the piston rod fully extended, calculate the value of **D** (in inches) using the formula shown or the cylinder mounting diagram selected in step #2.
4. Locate the value of **D** (in inches) at the bottom of the **Selection Chart**. Enter the chart at this point and move vertically upward until intersecting with the horizontal line represent-

ing the required thrust which was selected in step #1. The band within which these lines intersect represents the minimum recommended piston rod diameter.

piston rod diameter selection instructions above) is less than 40", a stop tube is **not** required. However, if **D** is 40" or more, 1" of stop tube is recommended for every 10" (or fraction thereof) over 40".

Stop Tube Selection

Stop tubes enhance the transverse load carrying capability of a long stroke cylinder by increasing the distance between the piston and rod bearing at full extension. When the value of **D** (calculated from the

Cylinder Mounting Diagrams

Firmly Guided Rod End

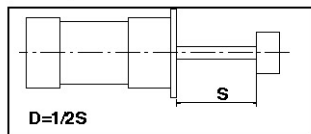

Head Trunnion

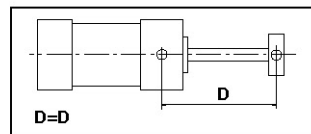

Unsupported Rod End

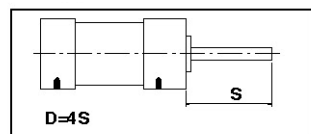

Supported Rod End

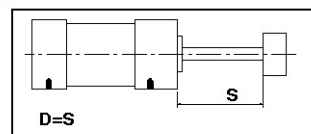

Supported Rod End

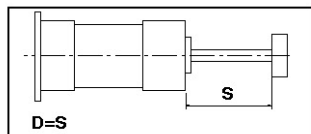

Firmly Guided Rod End

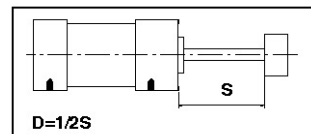

Unsupported Rod End

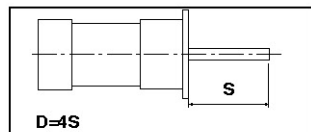

Cap Clevis or Cap Trunnion

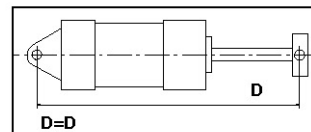

Selection Chart

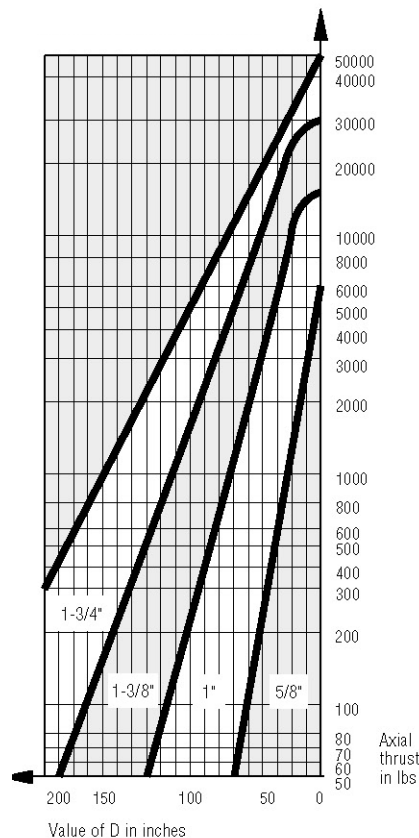

Series SL Technical Information

Cylinder Force and Volume Charts

Extend Forces in pounds (newtons)

BORE	PISTON AREA	PSI (BAR)										VOLUME CU FT (CM3) DISPLACEMENT PER INCH
		40 (3)	60 (4)	80 (6)	100 (7)	150 (10)	200 (14)					
1-1/8"	.99 (6.41)	40 (177)	60 (265)	80 (354)	99 (442)	149 (664)	200 (890)	.00057 (16)				
1-1/2"	1.77 (11.40)	71 (315)	106 (472)	142 (629)	177 (786)	266 (1179)	353 (1570)	.00102 (29)				
2"	3.14 (20.27)	126 (559)	189 (839)	251 (1119)	314 (1398)	471 (2097)	628 (2793)	.00182 (52)				
2-1/2"	4.91 (31.67)	196 (874)	295 (1311)	393 (1748)	491 (2185)	737 (3277)	982 (4368)	.00284 (80)				
3-1/4"	8.30 (53.32)	332 (1477)	498 (2215)	664 (2953)	830 (3692)	1245 (5538)	1659 (7379)	.00480 (136)				
4"	12.57 (81.07)	503 (2237)	754 (3355)	1005 (4473)	1257 (5592)	1886 (8388)	2513 (11178)	.00727 (206)				
5"	19.64 (126.71)	785 (3491)	1178 (5240)	1571 (6988)	1964 (8736)	2946 (13104)	3928 (17472)	.01137 (322)				
6"	28.27 (182.39)	1130 (5026)	1696 (7544)	2262 (10061)	2827 (12574)	4240 (18860)	5654 (25149)	.01837 (520)				
8"	50.26 (324.26)	2010 (8940)	3015 (13411)	4020 (17881)	5026 (22356)	7539 (33533)	10052 (44711)	.02227 (631)				

Deduct these Forces for Retract Strokes

BORE	ROD AREA	PSI (BAR)										VOLUME CU FT (CM3) DISPLACEMENT PER INCH
		40 (3)	60 (4)	80 (6)	100 (7)	150 (10)	200 (14)					
3/8"	.112 (.72)	5 (20)	7 (30)	9 (40)	11 (50)	17 (75)	22 (100)	.0007 (2)				
1/2"	.196 (1.26)	8 (35)	12 (52)	16 (70)	20 (87)	30 (131)	39 (174)	.00011 (3)				
5/8"	.307 (1.98)	12 (53)	18 (80)	25 (111)	31 (138)	46 (205)	61 (271)	.0018 (5)				
1"	.785 (5.06)	31 (138)	47 (209)	63 (280)	70 (351)	118 (525)	157 (698)	.00045 (13)				
1-3/8"	1.485 (9.58)	59 (262)	89 (396)	119 (529)	149 (663)	222 (997)	297 (1321)	.00086 (24)				
1-3/4"	2.404 (15.51)	95 (423)	144 (641)	192 (854)	240 (1068)	360 (1601)	480 (2135)	.00139 (39)				

Eaton
Hydraulics Operations USA
14615 Lone Oak Road
Eden Prairie, MN 55344
USA
Tel: 952-937-9800
Fax: 952-294-7722
www.hydraulics.eaton.com

Eaton
Hydraulics Operations Europe
Route de la Longeraie 7
1110 Morges
Switzerland
Tel: +41 (0) 21 811 4600
Fax: +41 (0) 21 811 4601

Eaton
Hydraulics Operations Asia Pacific
11th Floor Hong Kong New World
Tower
300 Huaihai Zhong Road
Shanghai 200021
China
Tel: 86-21-6387-9988
Fax: 86-21-6335-3912

