

**IPFusion**

# Integrated Power Factor Correction Products

*with **plug-and-play** simplicity*



- Fully integrated PFCC solutions
- Plug-and-play installation
- Patented, UL listed packages to 120kVAR
- 240/480 and 600 volt ratings
- Precharged switching contactor
- Integral fused protection and indication
- Wall, floor or panel mounting
- NEMA 1, 12 or 3R enclosures
- 24/7 service and support



**BENSHAW**

# Power Factor Correction

---

## DEFINITION

Commercial and industrial power consumers typically seek to control power factor deviations in order to achieve more efficient utilization of purchased electrical energy. Power factor is a measure of the effective conversion of current into work output and is calculated as the ratio between the actual load power and the apparent load power. In any supply and distribution system, losses will occur as part of the normal transmission of electrical power through the system. Under ideal circumstances, a power factor of 1.0 represents the most efficient utilization of the distributed electrical energy. As loss is accumulated in the supply system, the power factor drops below unity and is typically measured as a percentage of this ideal situation.

A relatively poor power factor is typically generated by a significant phase difference between the voltage waveform and the current waveform at the load. It is most typically observed in the presence of an inductive load, such as an induction motor, a power transformer, ballast and the like. These are typically found in great numbers in industrial and commercial facilities. Moreover, in many industrial settings, the utilization of multiple inductive motors which are continuously being cycled on and off, in a random pattern, may cause unique discontinuities or phase differences between the voltage and current at the various loads. As a matter of efficiency and cost-savings, the increase of power factor, as close as possible to unity, represents not only a more efficient utilization of power, but a reduced cost of operation. In many situations, power companies apply premium charges to users who exhibit poor power factor characteristics.

Power factor correction is typically done in the form of the addition of capacitance to circuits which include induction motors. These are applied to reduce the inductive component of the current and, subsequently, reduce losses. In a typical motor load, a portion of the total current drawn by the motor represents the magnetizing current, which establishes the flux in the magnetic field required for motor operation. The magnetizing current is necessary for the motor's operation, but does not contribute to the work output of the motor. In many cases, power factor correction is applied to reduce the effect of the magnetizing current of the motor.

# Integrated Power Factor Correction Module

## UNIT DIAGRAM

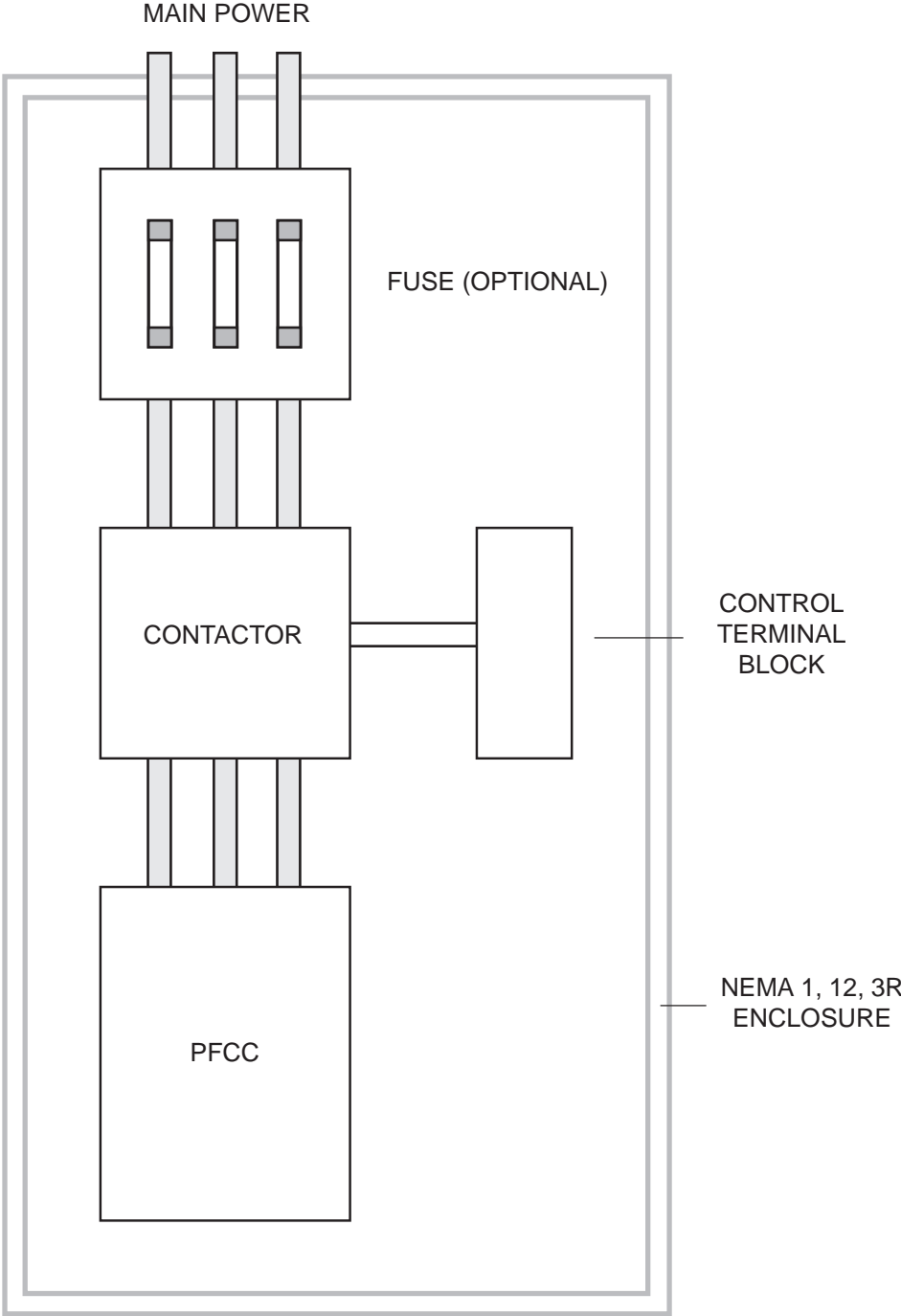

# IPFusion

## INTEGRATED POWER FACTOR CORRECTION PRODUCTS 480 & 600V / 7.5 - 120KVAR



### Standard Features:

- ◆ Non-fusible and fusible configurations
- ◆ Blown fuse indicator
- ◆ Control terminal block
- ◆ PFCC control contactor
- ◆ KVAR rated capacitors
- ◆ UL listed
- ◆ NEMA 1, 12 and 3R enclosures available

## IPFusion Power Factor Correction Product Highlights:

IPFusion is a patented, integrated power factor correction product family that contains presized, preselected components within a modular housing structure. Benshaw's IPFusion units have been pre-engineered and pre-assembled for simple plug and play power factor correction.

IPFusion power factor correction units are also designed to mate easily to your load—both electrically and physically. They occupy a minimum amount of space for ease of mounting near the load. Each unit includes the housing, terminal blocks, capacitor, precharge control and a contactor.

Integrated fuse protection is optional.

IPFusion units can be manually or automatically engaged and may be remotely monitored for status.

### Safety. Precision. Convenience.

The components of each integrated power factor correction unit are sized and selected to precisely match the ampacity of a load, ensuring optimum performance and reliability at the lowest possible cost.

In addition, all IPFusion power factor correction units are UL Listed for assurance of safe operation.

An optional fuse block and fuses can be provided for short circuit and thermal overload protection of the capacitor components, with the fuse block interconnected with the contactor through a contactor fuse interconnect.

### RSC Capacitor Switching Contactors

Benshaw's RSC series contactors include auxiliary contacts to provide a second set of switches that close prior to the main contacts. These auxiliary contacts are connected to high resistance wire that precharges the circuit. A second auxiliary contact is also provided to indicate the closed and open status of the main contact. The second auxiliary contact is physically connected to the main contact and is closed and opened simultaneously.

Use of auxiliary contacts in the power factor correction unit reduces voltage spikes at the time of initial contact by allowing a certain amount of voltage to pass to components prior to the main voltage surge. This reduces wear and maintenance and prolongs the life of the contactor and other components.

Power factor correction capacitors are typically wired in parallel with the motor load at various points in the distribution system. In situations where

### Guaranteed ... for two full years.

*Only Benshaw has a two year guarantee.*

Benshaw power factor correction products are guaranteed for two full years. Other manufacturers limit their warranties to just one year. But at Benshaw, we believe that, because we build them better, we can guarantee them longer. We call that "the Benshaw Promise."



# IPFusion, continued

a variety of inductive motors or loads are being switched on and off independently, it is desirable to apply the capacitance to the individual load. For that reason, it is important that power factor correction be specifically matched to the inductive load with which it is associated.

In an ideal system, a motor is corrected when its inductive reactance equals the capacitive reactance at the line frequency ... over or under correction of the load will result in poor performance and possible damage to the capacitors and motors. Over correction occurs when the resonance frequency is less than the line frequency.

Each inductive load—especially electric motors—requires a properly sized power factor correction capacitor. While a helpful starting point may be found in standard look-up tables or other theoretical predictors of optimum capacitance, the better practice is to specifically match the capacitance to the measured characteristics of the particular motor design.

## IPFusion Packages

An IPFusion package includes a housing—which supports at least one capacitor—control and power terminal blocks, precharge controls, all interconnecting wires, and a contactor for selective engagement of the capacitor into the load circuitry.

The capacitor and contactor are electrically connected to the load, and are engaged during the initial phase of load activation.

IPFusion units are constructed to the KVAC of the specific capacitor and therefore to the ampacity of the associated load. Both criteria are used to determine the appropriate contactor and selection of fuses which are able to accept the given level of current.

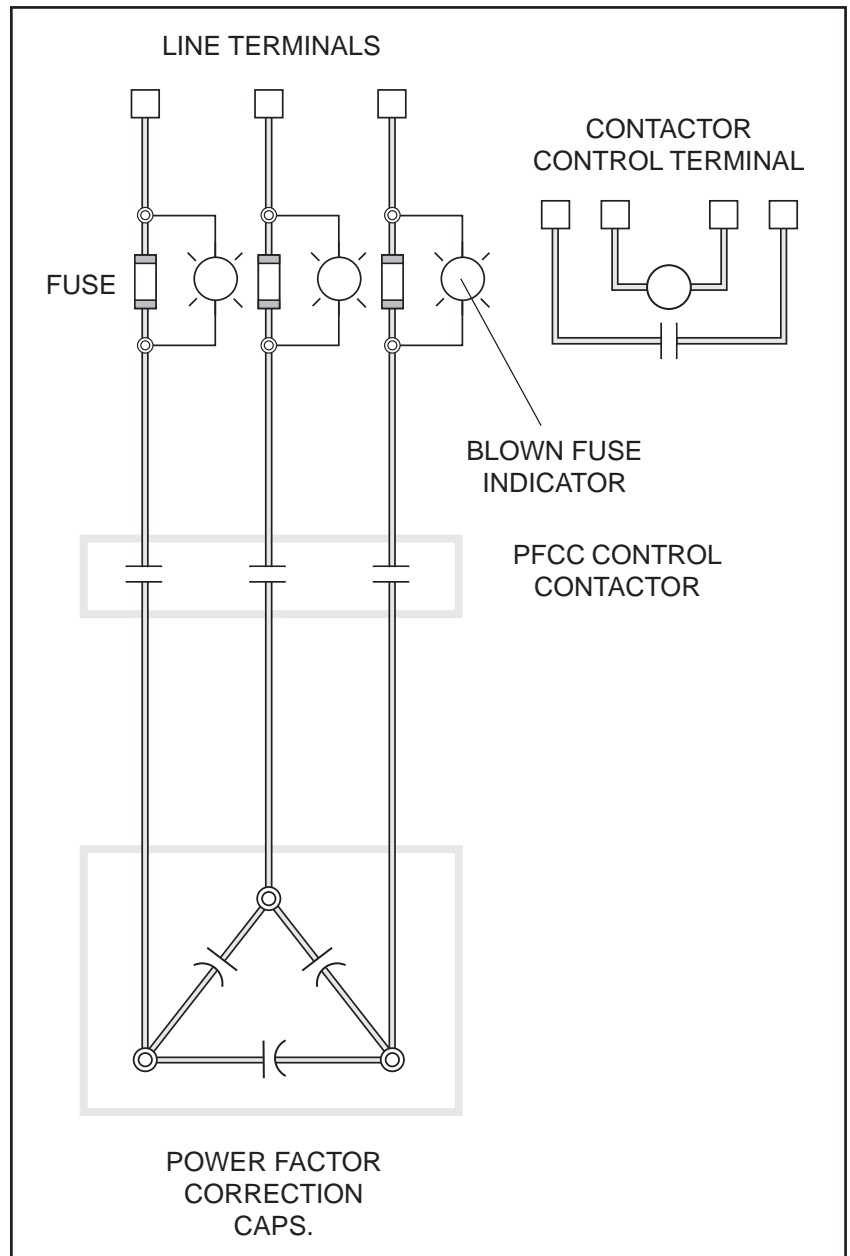

IPFusion - Outside Delta Schematic

## World-class after-market service and support—whenever and wherever needed...

# 7x24

Benshaw provides comprehensive support, with web-based tools and dedicated, knowledgeable staff available 7-days-a-week, 24-hours-a-day to answer your questions, dispatch a field service technician or coordinate an emergency parts request.

Repairs, spares, field engineering, retrofits and training services—whenever and wherever needed—are all part of Benshaw's commitment.



[www.BenshawExpress.com](http://www.BenshawExpress.com) offers a guaranteed two-hour emergency response on many starters and drives from warehouses around the country

- ◆ 7x24 same day shipment.
- ◆ Air or truck delivery.
- ◆ Airport pick-up or door-to-door service.



**7x24 Phone Support** from Benshaw operations centers in Pittsburgh, Listowel (Canada), Detroit and Phoenix provides:

- ◆ Technical assistance.
- ◆ Overnight parts shipment.
- ◆ Service dispatch.



**Training courses** are available in a classroom or a hands-on environment:

- ◆ Basic electrical maintenance.
- ◆ Electronic maintenance and diagnostics.
- ◆ New product orientations.
- ◆ Customized systems (maintenance- or operations-based).



**Regional/International Field Service** by a skilled technician, engineer or complete team, if needed, is available for:

- ◆ Start-up commissioning.
- ◆ Field repairs.
- ◆ Field analysis/data collection.
- ◆ Preventive maintenance.



**Repairs** are made by trained, experienced personnel, using the latest diagnostic and test equipment to service:

- ◆ Printed circuit boards.
- ◆ Power electronic control assemblies.
- ◆ Electrical sub-assemblies.

### United States

Pittsburgh, Pennsylvania  
 Indianapolis, Indiana  
 Syracuse, New York  
 Boston, Massachusetts  
 Charlotte, North Carolina  
 Birmingham, Alabama  
 Los Angeles, California  
 Detroit, Michigan  
 Chicago, Illinois  
 Phoenix, Arizona  
 Seattle, Washington  
 Denver, Colorado  
 Houston, Texas  
 Mobile, Alabama  
 Philadelphia, Pennsylvania

### Canada

Listowel, Ontario  
 Toronto, Ontario  
 Montreal, Quebec  
 Calgary, Alberta

### Brazil

### Ecuador

### Venezuela

### Columbia

### Peru

### Chile

### Argentina

### China

### Australia

### Philippines

### Korea

### Singapore

### Germany

### Mexico

### Russia

### Turkey

### Egypt

### Saudi Arabia

### United Arab Emirates

### Bahrain

### Kuwait

### BENSHAW Inc.

1659 East Sutter Road  
 Glenshaw, PA 15116  
 Phone: (412) 487-8235  
[www.benshaw.com](http://www.benshaw.com)

### BENSHAW Canada

550 Bright Street E  
 Listowel, Ontario N4W 3W3  
 Phone: (519) 291-5112

### Ben-Tech Industrial Automation

2904 Bond Street  
 Rochester Hills, MI 48309  
 Phone: (248) 299-7700

### BENSHAW Mobile

CSD Division  
 5821 Rangeline Road, Suite 202  
 Theodore, AL 36682  
 Phone: (251) 443-5911  
 Fax: (251) 443-5966

### BENSHAW High Point

EPC Division  
 645 McWay Drive  
 High Point, NC 27263  
 Phone: (336) 434-4445

### BENSHAW Pueblo

Trane Division  
 1 Jetway Court  
 Pueblo, CO 81001  
 Phone: (719) 948-1405

