

CONTINENTAL



HYDRAULICS™



PowrFlow™ PVX Vane Pumps



POWRFLOW™ PVX VANE PUMPS

YOUR SOURCE FOR VANE PUMPS FOR THE MOST DEMANDING APPLICATIONS

What Makes PowrFlow™ PVX Vane Pumps Your Best Buy?



Continental Hydraulics PowrFlow™ PVX Vane Pumps deliver the rugged, reliable performance and value you've come to expect in all our products. They outperform sensitive piston pumps in harsh environments. PVX Vane Pumps deliver faster response, and require less external compensation compared to fixed displacement designs.



Use PVX Vane pumps in tough applications such as on machine tools, in steel mills and mines, in shipyards and foundries, in automobile plants and textile mills, in pulp and paper mills, or any place else where reliable and economical hydraulic power is needed.

Features and Benefits

- 3000 PSI Rated at Full Rated Flow on most models
8 to 75 GPM Sizes
- Compact Design saves valuable space on your product, or in your power room.
- Pressure Compensation adjusts pump delivery to demand to save energy.
- Fast Response - 20 to 50 ms depending on model.
- Fast Recovery - 70 to 500 ms at minimum flow, depending on model.
- 100% Tested
- Quiet Operation
- Three Year Warranty

Compensator Options for All Kinds of Applications

- Single Stage
- Two Stage
- Load Sensing
- Two Pressure
- Torque Limiting

Hydraulic Centering Pads

Hydraulic pressure operated pistons keep the pressure ring centered to reduce wear and noise.

Tandem Pump Capability

Available with splined shaft and tandem mount cover.

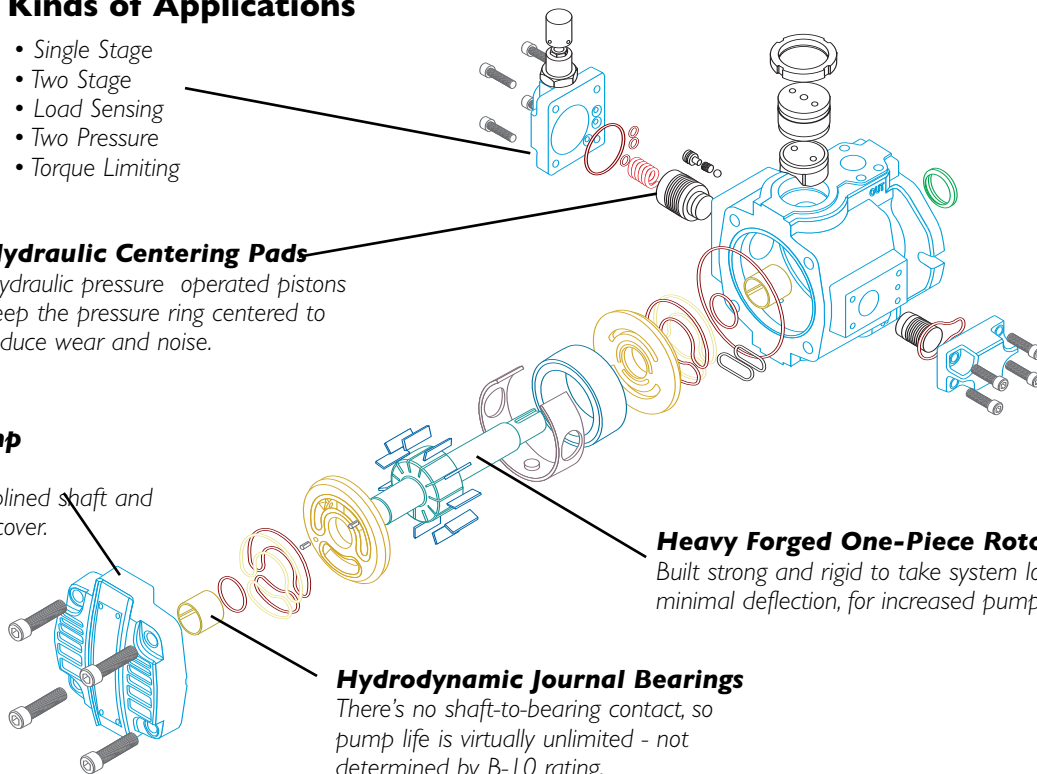

Heavy Forged One-Piece Rotor Shaft

Built strong and rigid to take system loads with minimal deflection, for increased pump life.

Hydrodynamic Journal Bearings

There's no shaft-to-bearing contact, so pump life is virtually unlimited - not determined by B-10 rating.

Introduction and Benefits	2
PVX-8 Performance Specifications	3
PVX-8 Performance Graphs	4
PVX-8 Dimension Drawings	5-6
PVX-8 Code Sheet	7
PVX-11 Performance Specifications	8
PVX-11 Performance Graphs	9
PVX-15 Performance Specifications	10
PVX-15 Performance Graphs	11
PVX-11/15 Dimension Drawings	12-14
PVX-11/15 Code Sheet	15
PVX-20 Performance Specifications	16
PVX-20 Performance Graphs	17
PVX-29 Performance Specifications	18
PVX-29 Performance Graphs	19
PVX-36 Performance Specifications	20
PVX-36 Performance Graphs	21
PVX-20/29/36 Dimension Drawings	22-23
PVX-20/29/36 Code Sheet	24
PVX-46 Performance Specifications	25
PVX-46 Performance Graphs	26
PVX-60 Performance Specifications	27
PVX-60 Performance Graphs	28
PVX-75 Performance Specifications	29
PVX-75 Performance Graphs	30
PVX-46/60/75 Dimension Drawings	31-32
PVX-46/60/75 Code Sheet	33
Adapter Kits - Combinations Using "P1" Pumps	34
Front Pump and Adapter Dimension Drawing	35
Through Drive Horsepower	35
PVX Pump Controls	36-37
Reaction Characteristics and Shock Clipper Function	38
PVX-8/11/15 Repair Parts - Compensators	39
PVX-20/29/36/46/60/75 Repair Parts - Compensator	40
Stroke Limiter Adjustment Chart	41
PVX-8/11/15 Repair Parts Kits	42
PVX-8/11/15 Repair Parts -	
Bearing Installation	43
Torque Ratings	43
PVX-20/29/36/46/60/75 Repair Parts Kits	44
Vane Tip Orientation	45
Trouble Shooting	46
PVX Vane Pumps are Designed to be Quiet	47
PVX Vane Pumps — Optimum Operating Viscosities	48

PVX SERIES VANE PUMPS

INTRODUCTION AND BENEFITS

This catalog introduces a new line of enhanced performance variable displacement pressure compensated vane pumps from Continental Hydraulics. Sizes range from 8 to 36 gpm; 3000 psi in "A", "B", or "C" SAE mounts and 46 to 75 gpm; 2500 psi in "D" SAE mount.

The pumps are designed to meet requirements of the machine tool, general machinery and other markets where low noise, high performance and competitive pricing are needed.

Note these improvements and features:

- Continuous duty ratings.
- Speed range 1150, 1450 and 1750 rpm.
- High efficiency at full flow.
- Quiet operation.
- Modern appearance.
- Improved ring and vane wear.
- Fast response and recovery times.
- Reduced envelope size.
- Improved controls with shock clipper.
- Conforms to the latest SAE, ISO, NFPA and ANSI standards.
- Allows full horsepower transference to pump 2 on tandem mounted pumps.
- 3 year warranty.

Benefits include:

- Competitively priced with other manufacturers of vane and axial piston pumps.
- Reduced sound levels help meet government and purchased sound requirements.
- High performance and long life design.
- Fast reaction time for critical system demands.
- Pressure compensated pumps controls delivery to circuit demands thereby conserving energy.
- Hydrodynamic journal bearings provide long life and quiet operation.
Repair kits are available from local distributor or the factory.
- Control option include single stage, two stage; load sensing, and torque limiting on most models.
- Shock clipper reduces shock pressure increasing system component life and stability.



PERFORMANCE SPECIFICATIONS

Displacement (Nominal)	1 in ³ /rev. (16 cm ³ /rev.)	
Displacement (Actual)	1.06 in ³ /rev.(16.8 cm ³ /rev.)	
Flow at 1750 rpm*	7.57 gpm (28.6 l/min.)	
Maximum continuous pressure	3000 psi (210 bar)	
Pressure compensating range	Single stage	200-3000 psi (14-210 bar) Minimum 190 psi (13 bar)
	Two stage	300-3000 psi (21-210 bar) Minimum 290 psi (19 bar)
Maximum transient spike pressure	3800 psi (260 bar)	
Maximum case pressure	10 psi (0.7 bar)	
Speed range	1150 - 1800 rpm	
Direction of rotation (viewed shaft end)	Right hand (clockwise)	
Case drain flow while compensating at 1800 rpm	1000 psi (70 bar)	0.6 gpm (2.3 l/min.)
	2000 psi (140 bar)	0.9 gpm (3.4 l/min.)
	3000 psi (210 bar)	1.26 gpm (4.8 l/min.)
Maximum inlet vacuum at sea level	6 inches Hg (152 mm Hg)	
Mounting - SAE 2 bolt flange (ISO 3019/1)	S.A.E 'A' - 2 bolt flange	
Mounting position	Unrestricted	
Port sizes	Inlet	#16 S.A.E.
	Outlet	#12 S.A.E.
	Case drain	#8 S.A.E.
	Clipper control drain (opt.)	#6 S.A.E.
	Remote control (opt.)	#4 S.A.E.
Fluid viscosity at operating temperature	Minimum	100 SUS (21 cSt)
	Maximum	1000 SUS (216 cSt)
	Optimum	150-250 SUS (32-54 cSt)
	Maximum start-up	4000 SUS (864 cSt)
Seals	Standard fluorocarbon	

Response time (Circuit dependent)	Full flow to minimum flow	20-35 ms
Response time (Circuit dependent)	Minimum flow to full flow	50-135 ms - single stage compensator
Weight	Single stage	34 lbs. (16.5 kg)
	Two stage	38 lbs. (17.3 kg)

* Flows are actual. Volumetric efficiencies shown in technical data are taken into account.

OTHER SPECIFICATIONS

- DRIVE** - Pump to be connected to prime mover by means of a flexible coupling that is aligned to a maximum of .006" (.152 mm) total indicator reading. No overhung or side loads permitted. Alignments greater than .006" (.152 mm) indicator reading could cause increased noise and vibration as well as premature shaft seal wear resulting in leakage.
- FLUID RECOMMENDATIONS** - A premium quality hydraulic oil with anti-wear additives is recommended, but not required. Consult factory for use with water base fire resistant fluids.
- FLUID TEMPERATURE** - Normal inlet fluid temperature should not exceed 140° F. (60° C.). Always select a fluid for optimum viscosity at operating temperature. Consult factory for applications assistance when inlet fluid temperatures over 140° F. (60° C.) are expected.
- FILTRATION** - Fluid cleanliness per ISO/DIS 4406 should be 18/15 or better for pressures of 2000 psi (140 bar) or less. For continuous operating pressures of 2000 to 3000 psi (140 to 210 bar), fluid cleanliness should be 17/13 or better.

PVX-8 VANE PUMPS

VARIABLE DISPLACEMENT, PRESSURE COMPENSATED

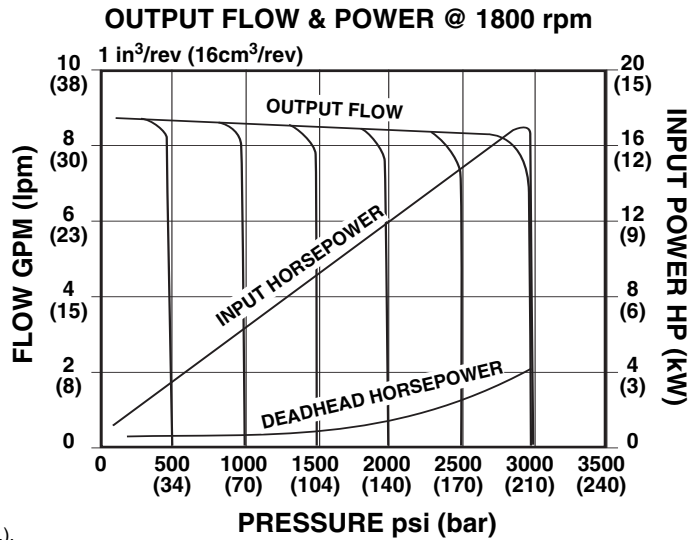

Data plotted: With oil at 120° F. (49° C.).
Viscosity @ 120° F. (49° C.) = 140 SUS.

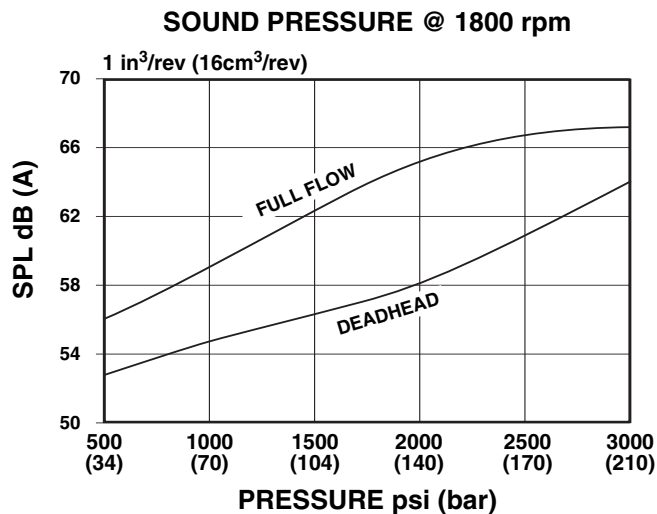
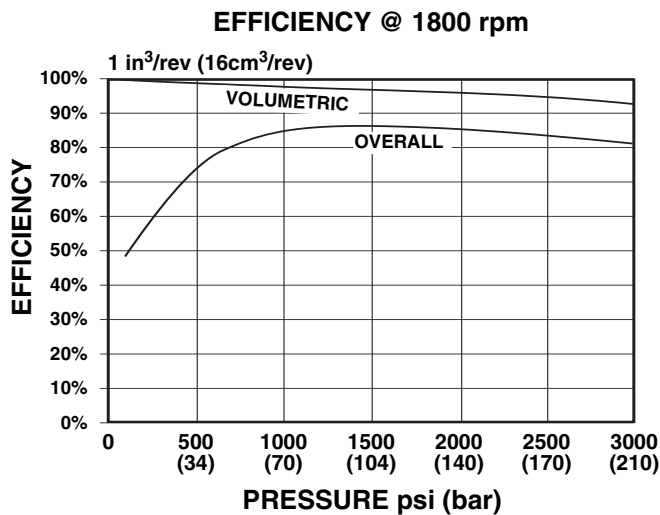

Sound pressure levels measured in a hemi-anechoic chamber with microphone placed one (1) meter away at discrete locations. Sound pressure levels are spacially and time-weighted averaged.

PVX-8 VANE PUMPS

VARIABLE DISPLACEMENT, PRESSURE COMPENSATED

S.A.E. 'A' Flange, RH Rotation

INCHES
(millimeters)

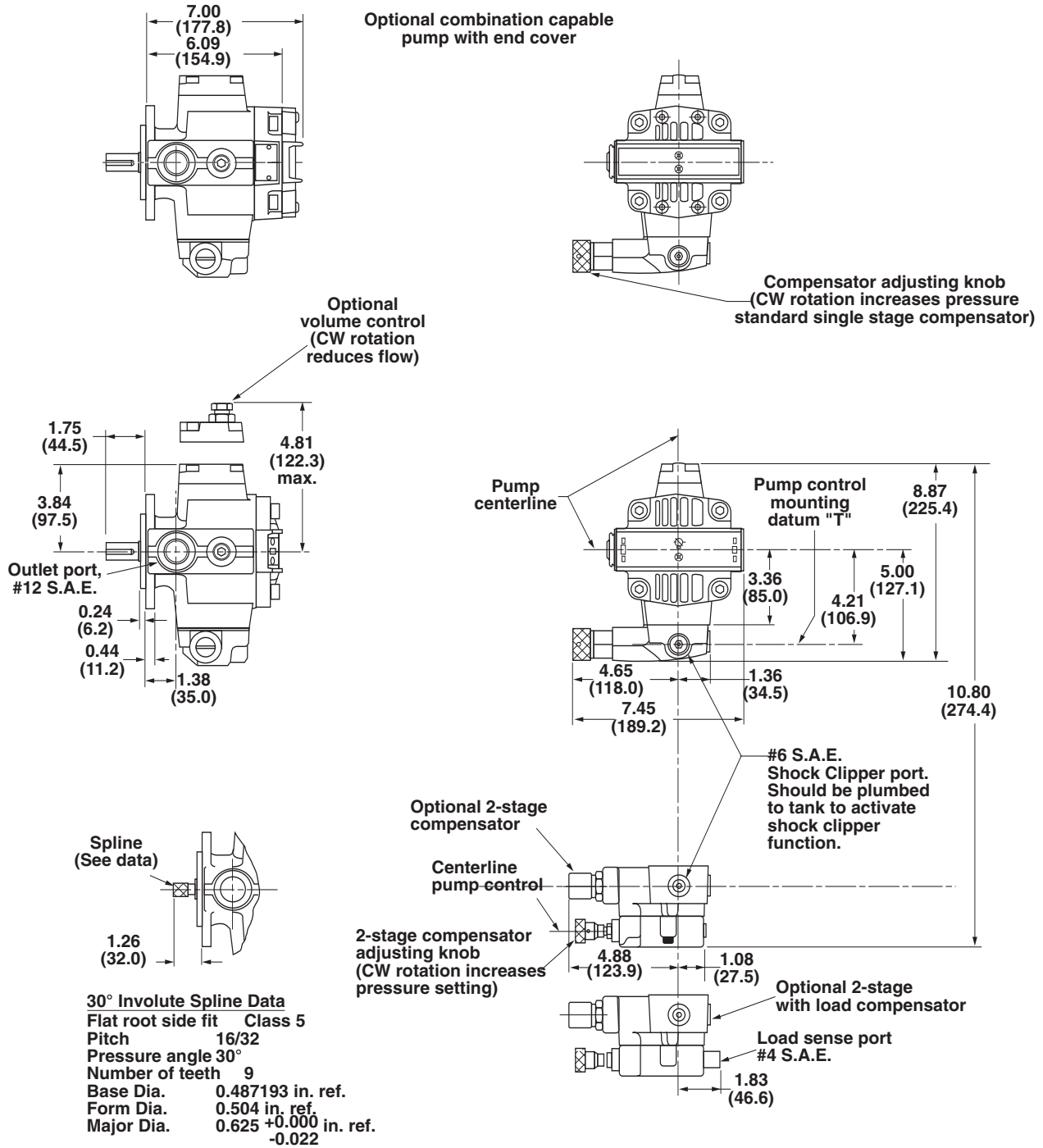

PVX-8 VANE PUMPS

VARIABLE DISPLACEMENT, PRESSURE COMPENSATED

S.A.E. 'A' Flange, RH Rotation

INCHES
(millimeters)

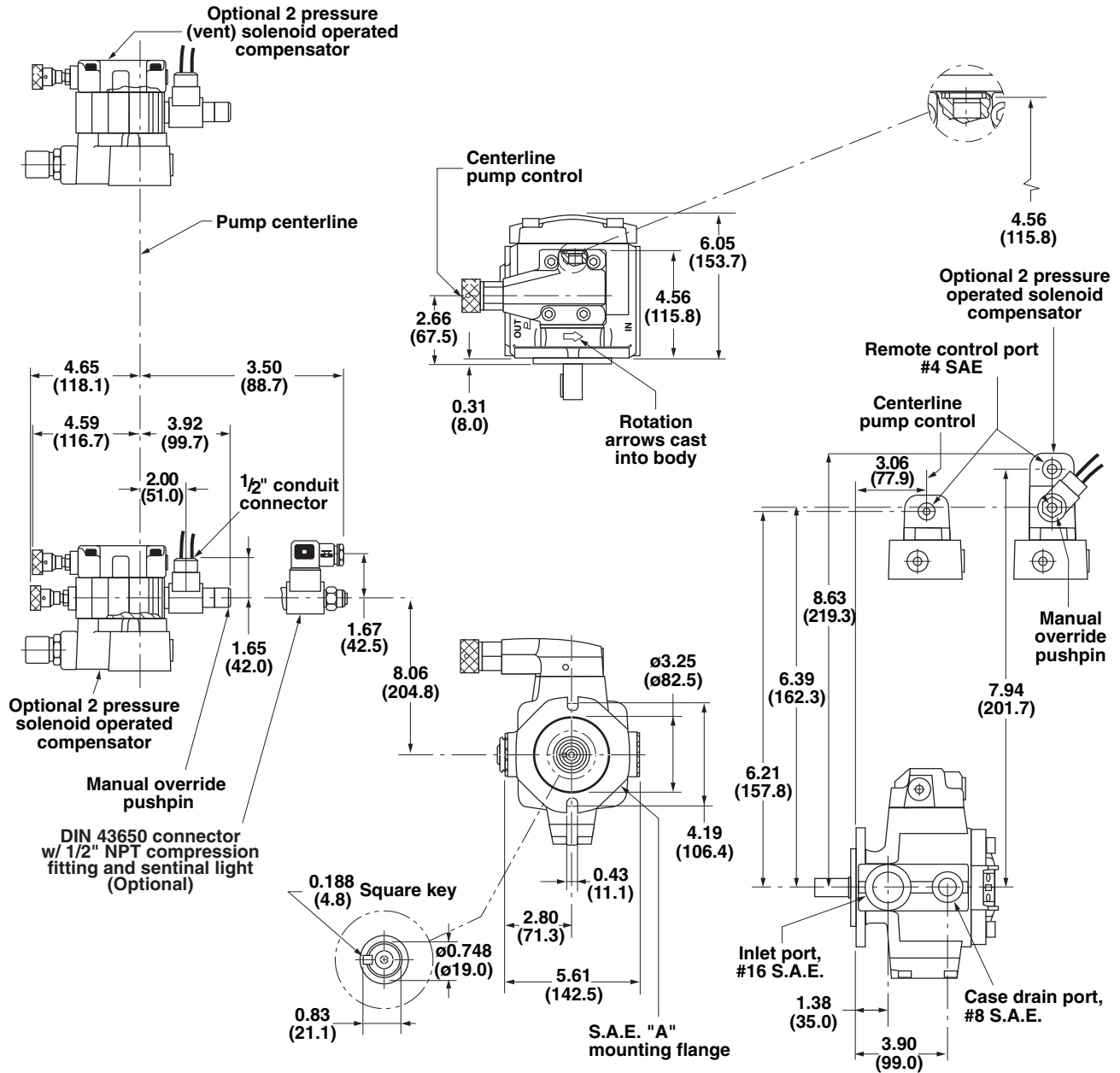

PVX-8 VANE PUMPS



VARIABLE DISPLACEMENT, PRESSURE COMPENSATED

PVX — 8B 30 — RF — — 1S — A

GPM @RPM RATED

CODE	GPM MAX.	RPM RATED
8B	7.4	1750

SEALS

CODE	TYPE
O	BUNA N
P	VITON (STANDARD)
W	WATER GLYCOL

TANDEM*

CODE	DESCRIPTION
P1	WITH COVER PLATE ONLY
21	FOR REAR PUMP SAE "A" SPLINED W/COVER PLATE
51	FOR REAR PUMP SAE "A" KEYED W/COVER PLATE

VOLTAGE*

CODE	DESCRIPTION
12	12 VOLT
24	24 VOLT
115	115 VOLT
220	220 VOLT

* Required for Control Options Codes 27 - 30.

PRESSURE RANGE

CODE	PRESSURE (PSI)
30	3000

ROTATION/MOUNTING

CODE	ROTATION	MOUNTING
RF	CW	FLANGE

* P1 option provides a combination-capable rear cover. Code 21 and 51 are SAE Adapter kits and require P1 rear cover.

MOUNTING/DRIVE/PORTING

CODE	DESCRIPTION
1S	SAE FLANGE/KEY/PORT (THREADED)

SHAFT

CODE	DESCRIPTION
OMIT	KEYED SHAFT (STANDARD)
12	DRIVE SPLINE PER SAE 744C

Not Available with Tandem Option

CONTROL OPTIONS

CODE	DESCRIPTION
OMIT	MAXIMUM VOLUME CONTROL (STANDARD)
01	PRESSURE REGULATOR (SINGLE STAGE)
17	TWO (2) STAGE (REMOTE) PRESSURE CONTROL
19	LOAD SENSE CONTROL
27*	SOLENOID OPERATED TWO PRESSURE NORMAL OPEN/LOW PRESSURE (ENERGIZE TO HIGH)
28*	SOLENOID OPERATED TWO PRESSURE NORMAL CLOSED/HIGH PRESSURE (ENERGIZE TO LOW)
29*	SOLENOID OPERATED TWO PRESSURE NORMAL OPEN/LOW PRESSURE (ENERGIZE TO HIGH)
30*	SOLENOID OPERATED TWO PRESSURE NORMAL CLOSED AT PRESSURE (ENERGIZE TO VENT)

* Requires voltage selection.

Typical Ordering Code:

PVX-8B30-RF-P-1SP12101-A

PVX-11 VANE PUMPS

VARIABLE DISPLACEMENT, PRESSURE COMPENSATED



NOTE: See pages 12 thru 14 for PVX-11 dimensions.

PERFORMANCE SPECIFICATIONS

Displacement (Nominal)	1.5 in ³ /rev. (25 cm ³ /rev.)	
Displacement (Actual)	1.66 in ³ /rev.(27.4 cm ³ /rev.)	
Flow at 1750 rpm*	11.36 gpm (43.0 l/min.)	
Maximum continuous pressure	3000 psi (210 bar)	
Pressure compensating range	Single stage	200-3000 psi (14-210 bar) Minimum 190 psi (13 bar)
	Two stage	300-3000 psi (21-210 bar) Minimum 290 psi (19 bar)
Maximum transient spike pressure	4000 psi (280 bar)	
Maximum case pressure	10 psi (0.7 bar)	
Speed range	1150 - 1800 rpm	
Direction of rotation (viewed shaft end)	Right hand (clockwise)	
Case drain flow while compensating at 1800 rpm	1000 psi (70 bar)	0.6 gpm (2.3 l/min.)
	2000 psi (140 bar)	1.1 gpm (4.2 l/min.)
	3000 psi (210 bar)	1.4 gpm (5.3 l/min.)
Maximum inlet vacuum at sea level	6 inches Hg (152 mm Hg)	
Mounting - SAE 2 bolt flange (ISO 3019/1)	S.A.E 'B' - 2 bolt flange	
Mounting position	Unrestricted	
Port sizes	Inlet	#24 S.A.E.
	Outlet	#16 S.A.E.
	Case drain	#8 S.A.E.
	Clipper control drain (opt.)	#6 S.A.E.
	Remote control (opt.)	#4 S.A.E.
Fluid viscosity at operating temperature	Minimum	100 SUS (21 cSt)
	Maximum	1000 SUS (216 cSt)
	Optimum	150-250 SUS (32-54 cSt)
	Maximum start-up	4000 SUS (864 cSt)
Seals	Standard fluorocarbon	

Response time (Circuit dependent)	Full flow to minimum flow	20-35 ms
Response time (Circuit dependent)	Minimum flow to full flow	70-185 ms - single stage compensator
Weight	Single stage	61 lbs. (27.7 kg)
	Two stage	65 lbs. (29.4 kg)

* Flows are actual. Volumetric efficiencies shown in technical data are taken into account.

OTHER SPECIFICATIONS

- **DRIVE** - Pump to be connected to prime mover by means of a flexible coupling that is aligned to a maximum of .006" (.152 mm) total indicator reading. No overhung or side loads permitted. Alignments greater than .006" (.152 mm) indicator reading could cause increased noise and vibration as well as premature shaft seal wear resulting in leakage.
- **FLUID RECOMMENDATIONS** - A premium quality hydraulic oil with anti-wear additives is recommended, but not required. Consult factory for use with water base fire resistant fluids.
- **FLUID TEMPERATURE** - Normal inlet fluid temperature should not exceed 140° F. (60° C.). Always select a fluid for optimum viscosity at operating temperature. Consult factory for applications assistance when inlet fluid temperatures over 140° F. (60° C.) are expected.
- **FILTRATION** - Fluid cleanliness per ISO/DIS 4406 should be 18/15 or better for pressures of 2000 psi (140 bar) or less. For continuous operating pressures of 2000 to 3000 psi (140 to 210 bar), fluid cleanliness should be 17/13 or better.

PVX-11 VANE PUMPS



VARIABLE DISPLACEMENT, PRESSURE COMPENSATED

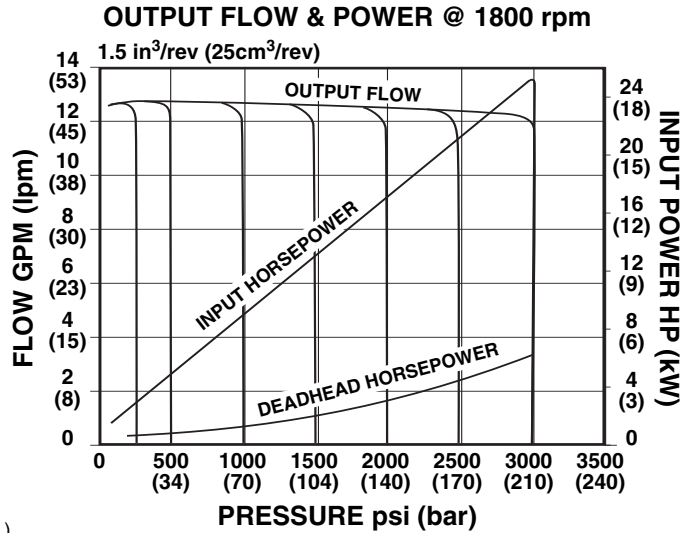

Data plotted: With oil at 120° F. (49° C.).
Viscosity @ 120° F. (49° C.) = 140 SUS.

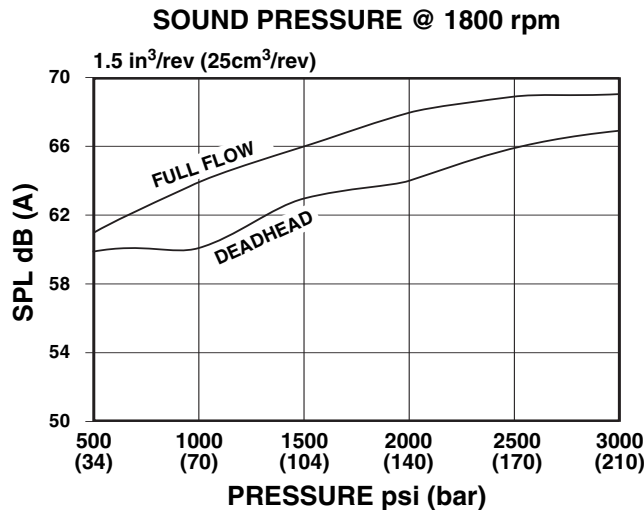
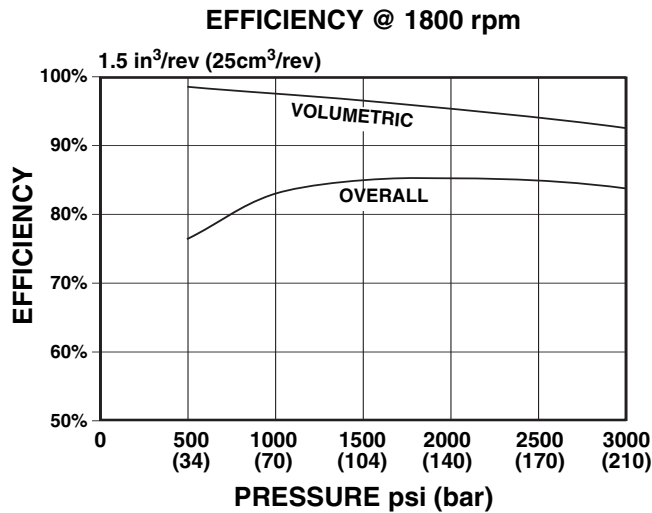

Sound pressure levels measured in a hemi-anechoic chamber with microphone placed one (1) meter away at discrete locations. Sound pressure levels are spatially and time-weighted averaged.

PVX-15 VANE PUMPS

VARIABLE DISPLACEMENT, PRESSURE COMPENSATED



NOTE: See pages 12 thru 14 for PVX-15 dimensions.

PERFORMANCE SPECIFICATIONS

Displacement (Nominal)	2 in ³ /rev. (32 cm ³ /rev.)	
Displacement (Actual)	2.04 in ³ /rev. (32 cm ³ /rev.)	
Flow at 1750 rpm*	15.15 gpm (57.3 l/min.)	
Maximum continuous pressure	3000 psi (210 bar)	
Pressure compensating range	Single stage	200-3000 psi (14-210 bar) Minimum 190 psi (13 bar)
	Two stage	300-3000 psi (21-210 bar) Minimum 290 psi (19 bar)
Maximum transient spike pressure	4000 psi (280 bar)	
Maximum case pressure	10 psi (0.7 bar)	
Speed range	1150 - 1800 rpm	
Direction of rotation (viewed shaft end)	Right hand (clockwise)	
Case drain flow while compensating at 1800 rpm	1000 psi (70 bar)	0.6 gpm (2.3 l/min.)
	2000 psi (140 bar)	1.1 gpm (4.2 l/min.)
	3000 psi (210 bar)	1.4 gpm (5.3 l/min.)
Maximum inlet vacuum at sea level	6 inches Hg (152 mm Hg)	
Mounting - SAE 2 bolt flange (ISO 3019/1)	S.A.E 'B' - 2 bolt flange	
Mounting position	Unrestricted	
Port sizes	Inlet	#24 S.A.E.
	Outlet	#16 S.A.E.
	Case drain	#8 S.A.E.
	Clipper control drain (opt.)	#6 S.A.E.
	Remote control (opt.)	#4 S.A.E.
Fluid viscosity at operating temperature	Minimum	100 SUS (21 cSt)
	Maximum	1000 SUS (216 cSt)
	Optimum	150-250 SUS (32-54 cSt)
	Maximum start-up	4000 SUS (864 cSt)
Seals	Standard fluorocarbon	

Response time (Circuit dependent)	Full flow to minimum flow	20-35 ms
Response time (Circuit dependent)	Minimum flow to full flow	70-185 ms - single stage compensator
Weight	Single stage	61 lbs. (27.7 kg)
	Two stage	65 lbs. (29.4 kg)

* Flows are actual. Volumetric efficiencies shown in technical data are taken into account.

OTHER SPECIFICATIONS

- **DRIVE** - Pump to be connected to prime mover by means of a flexible coupling that is aligned to a maximum of .006" (.152 mm) total indicator reading. No overhung or side loads permitted. Alignments greater than .006" (.152 mm) indicator reading could cause increased noise and vibration as well as premature shaft seal wear resulting in leakage.
- **FLUID RECOMMENDATIONS** - A premium quality hydraulic oil with anti-wear additives is recommended, but not required. Consult factory for use with water base fire resistant fluids.
- **FLUID TEMPERATURE** - Normal inlet fluid temperature should not exceed 140° F. (60° C.). Always select a fluid for optimum viscosity at operating temperature. Consult factory for applications assistance when inlet fluid temperatures over 140° F. (60° C.) are expected.
- **FILTRATION** - Fluid cleanliness per ISO/DIS 4406 should be 18/15 or better for pressures of 2000 psi (140 bar) or less. For continuous operating pressures of 2000 to 3000 psi (140 to 210 bar), fluid cleanliness should be 17/13 or better.

PVX-15 VANE PUMPS



VARIABLE DISPLACEMENT, PRESSURE COMPENSATED

OUTPUT FLOW & POWER @ 1800 rpm

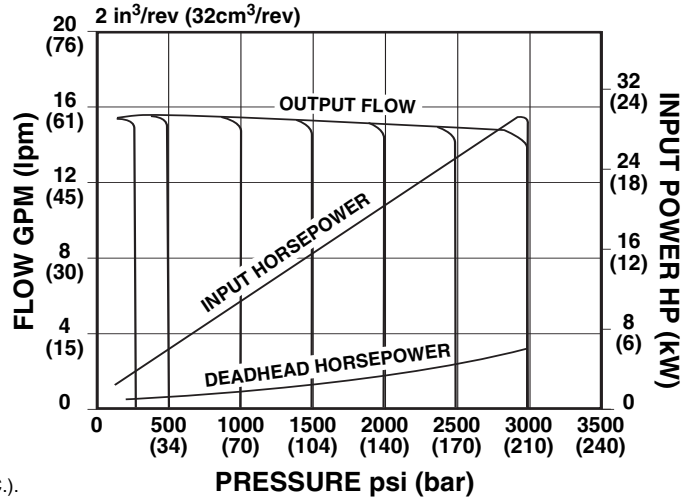

Data plotted: With oil at 120° F. (49° C.).
Viscosity @ 120° F. (49° C.) = 140 SUS.

EFFICIENCY @ 1800 rpm

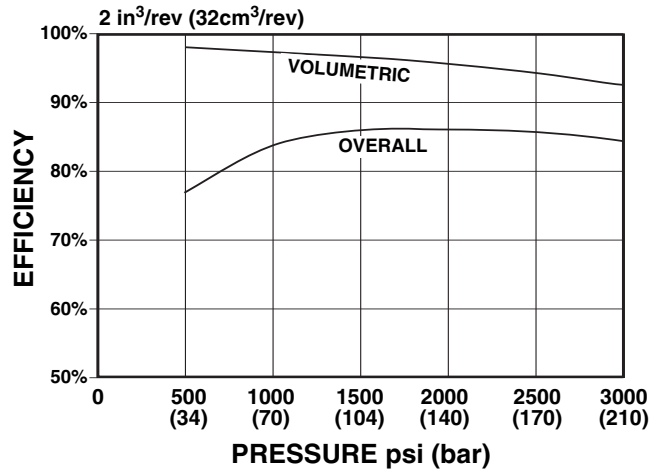

SOUND PRESSURE @ 1800 rpm

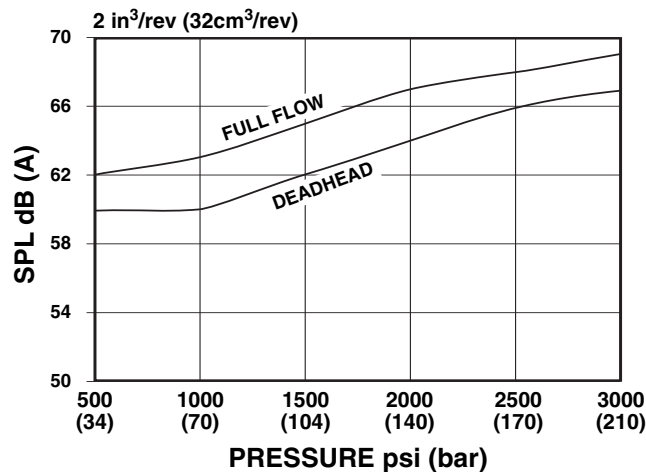

Sound pressure levels measured in a hemi-anechoic chamber with microphone placed one (1) meter away at discrete locations. Sound pressure levels are spatially and time-weighted averaged.

PVX-11/15 VANE PUMPS

VARIABLE DISPLACEMENT, PRESSURE COMPENSATED

S.A.E. 'B' Flange, RH Rotation

INCHES
(millimeters)

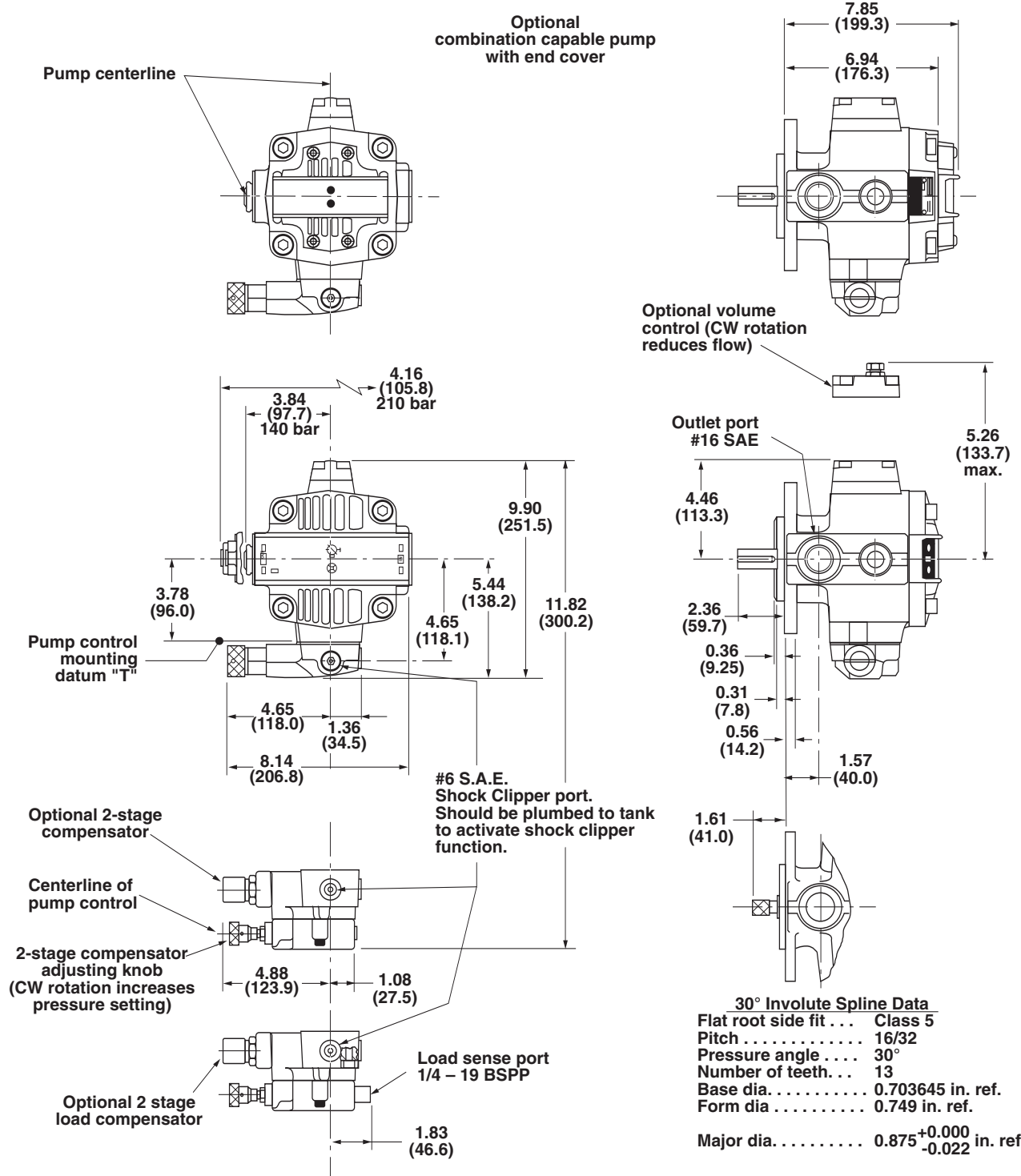

30° Involute Spline Data

Flat root side fit . . .	Class 5
Pitch	16/32
Pressure angle	30°
Number of teeth	13
Base dia.	0.703645 in. ref.
Form dia.	0.749 in. ref.
Major dia.	0.875 ^{+0.000} _{-0.022} in. ref.

PVX-11/15 VANE PUMPS

VARIABLE DISPLACEMENT, PRESSURE COMPENSATED

S.A.E. 'B' Flange, RH Rotation

INCHES
(millimeters)

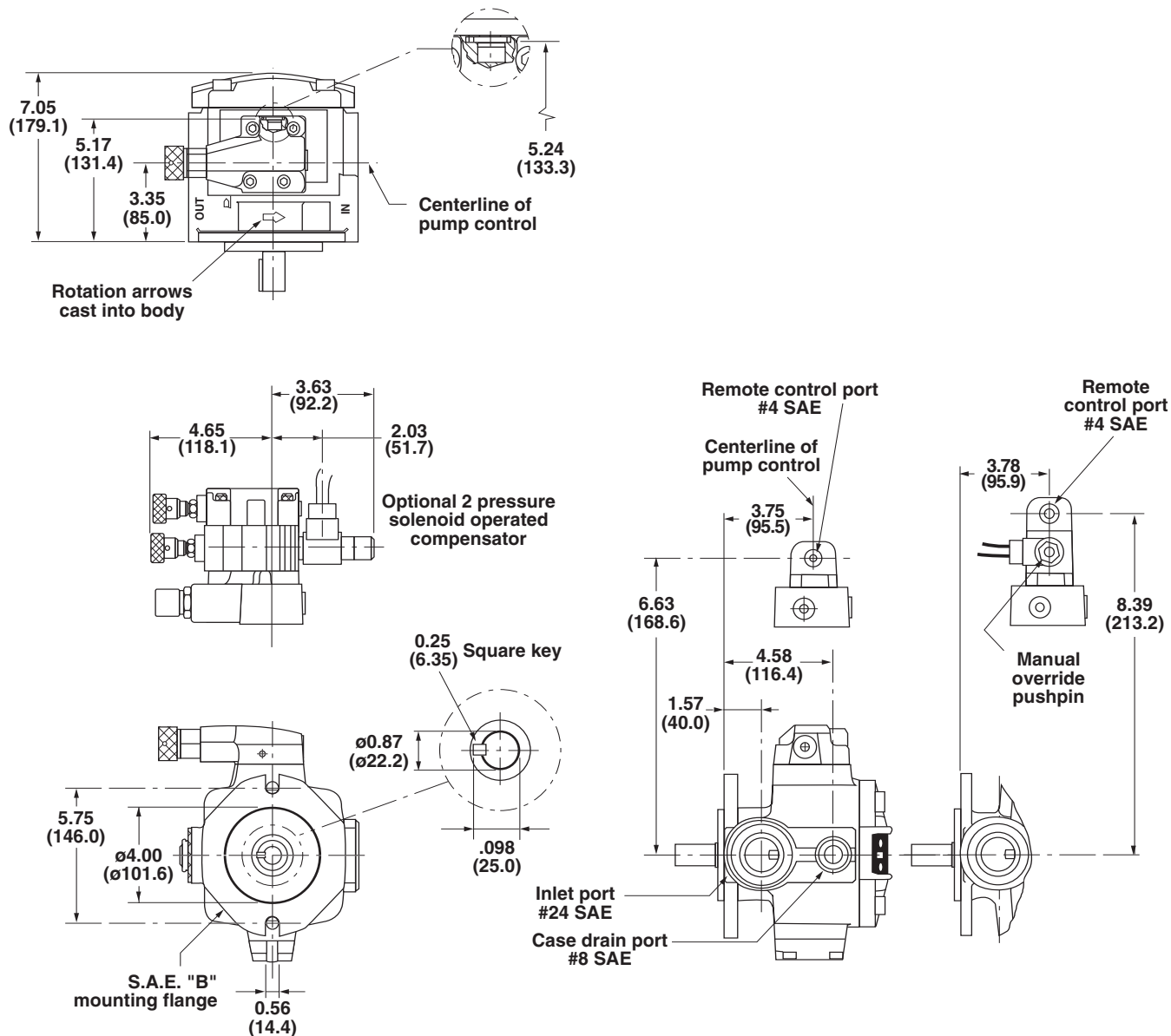

PVX-11/15 VANE PUMPS

VARIABLE DISPLACEMENT, PRESSURE COMPENSATED

S.A.E. 'B' Flange, RH Rotation

INCHES
(millimeters)

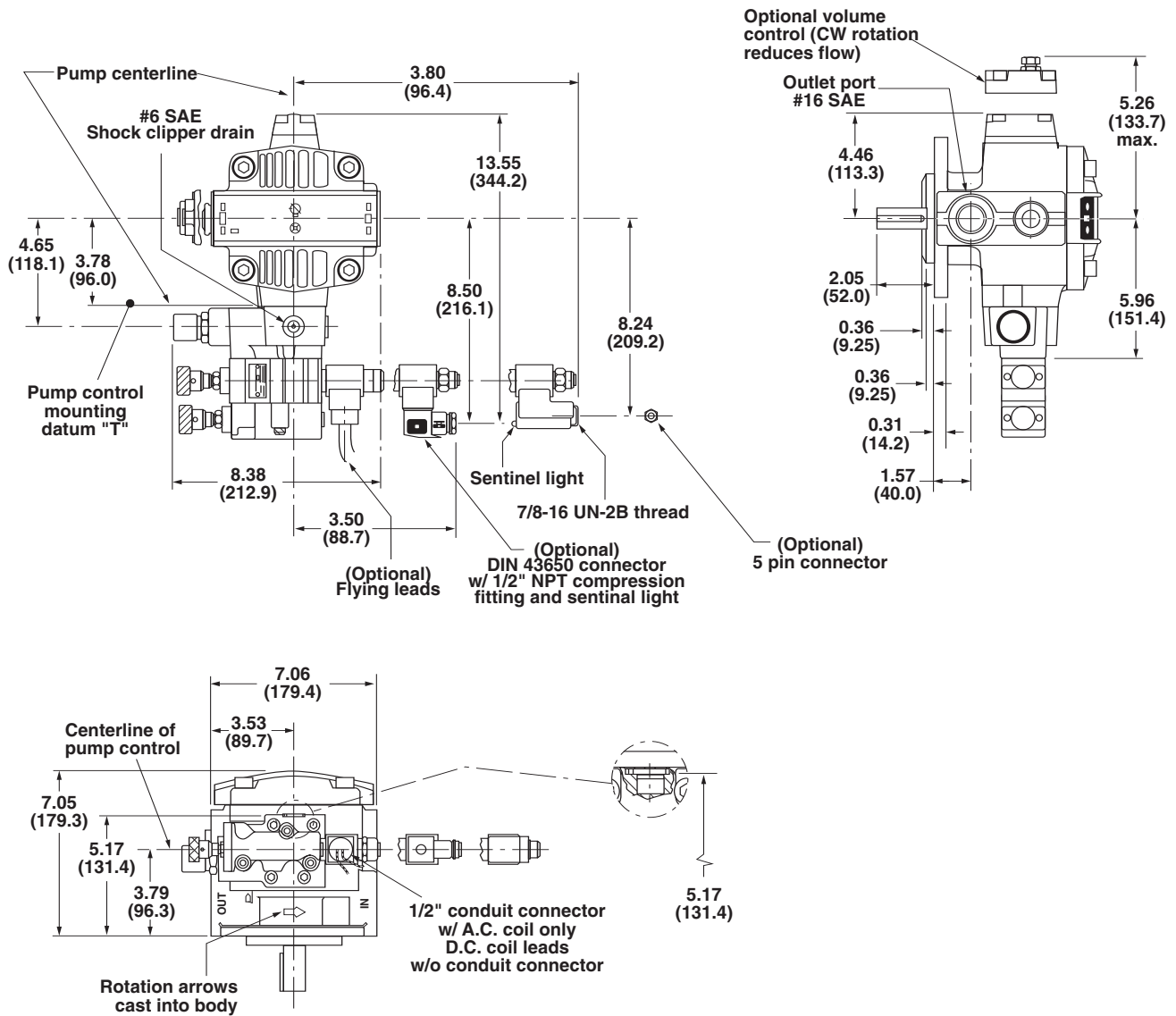

PVX-11/15 VANE PUMPS



VARIABLE DISPLACEMENT, PRESSURE COMPENSATED

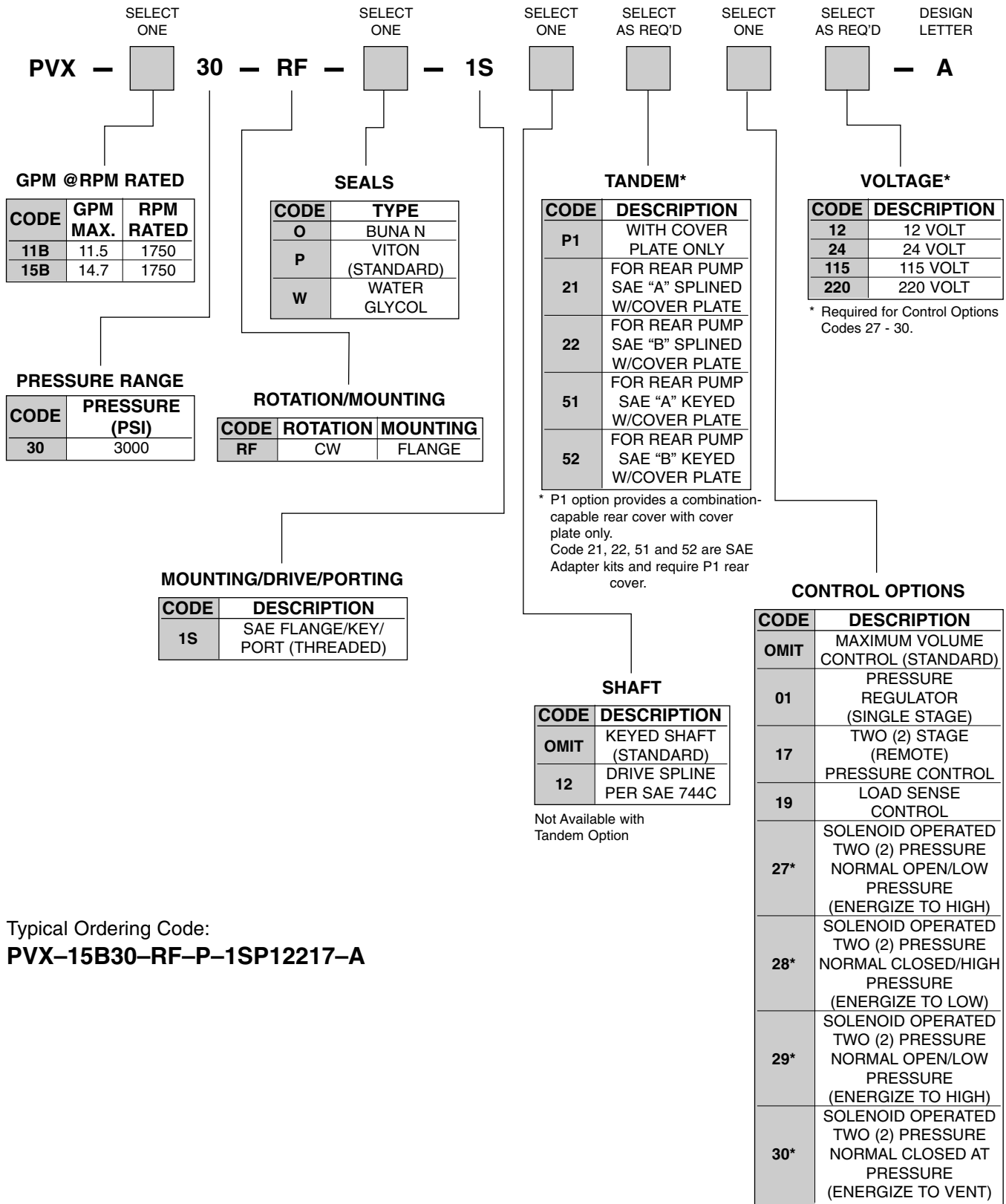

* Required for Control Options Codes 27 - 30.

* P1 option provides a combination-capable rear cover with cover plate only. Code 21, 22, 51 and 52 are SAE Adapter kits and require P1 rear cover.

* Requires voltage selection.

Typical Ordering Code:
PVX-15B30-RF-P-1SP12217-A

PVX-20 VANE PUMPS

VARIABLE DISPLACEMENT, PRESSURE COMPENSATED

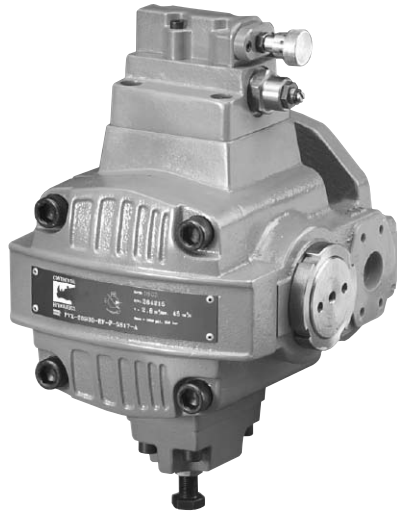

NOTE: See pages 22 and 23 for PVX-20 dimensions.

PERFORMANCE SPECIFICATIONS

Displacement (Nominal)	2.75 in ³ /rev. (45 cm ³ /rev.)
Displacement (Actual)	2.88 in ³ /rev. (47.3 cm ³ /rev.)
Flow at 1750 rpm*	20.83 gpm (72.8 l/min.)
Maximum continuous pressure	3000 psi (210 bar)
Pressure compensating range	Two stage 350-3000 psi (24-210 bar) Minimum 300 psi (21 bar)
Maximum transient spike pressure	4000 psi (280 bar)
Maximum case pressure	10 psi (0.7 bar)
Speed range	1150 - 1800 rpm
Direction of rotation (viewed shaft end)	Right hand (clockwise)
Case drain flow	1000 psi (70 bar) 1.5 gpm (5.7 l/min.)
while compensating	2000 psi (140 bar) 1.9 gpm (7.2 l/min.)
at 1800 rpm	3000 psi (210 bar) 2.5 gpm (9.5 l/min.)
Maximum inlet vacuum at sea level	6 inches Hg (152 mm Hg)
Mounting - SAE 2 bolt flange (ISO 3019/1)	S.A.E 'C' - 2 bolt flange
Mounting position	Unrestricted
Port sizes	Inlet 2" S.A.E.
	Outlet 1-1/4" S.A.E.
	Case drain #8 S.A.E.
	Remote control (optional) #4 S.A.E.
Fluid viscosity at operating temperature	Minimum 150 SUS (32 cSt)
	Maximum 1000 SUS (216 cSt)
	Optimum 200-300 SUS (43-65 cSt)
	Maximum start-up 4000 SUS (864 cSt)
Seals	Standard fluorocarbon

Response time (Circuit dependent)	Full flow to minimum flow	20-40 ms
Response time (Circuit dependent)	Minimum flow to full flow	100-250 ms - two stage compensator
Weight	Single stage	120 lbs. (55 kg)
	Two stage	128 lbs. (58 kg)

* Flows are actual. Volumetric efficiencies shown in technical data are taken into account.

OTHER SPECIFICATIONS

- **DRIVE** - Pump to be connected to prime mover by means of a flexible coupling that is aligned to a maximum of .006" (.152 mm) total indicator reading. No overhung or side loads permitted. Alignments greater than .006" (.152 mm) indicator reading could cause increased noise and vibration as well as premature shaft seal wear resulting in leakage.
- **FLUID RECOMMENDATIONS** - A premium quality hydraulic oil with anti-wear additives is recommended, but not required. Consult factory for use with water base fire resistant fluids.
- **FLUID TEMPERATURE** - Normal inlet fluid temperature should not exceed 140° F. (60° C.). Always select a fluid for optimum viscosity at operating temperature. Consult factory for applications assistance when inlet fluid temperatures over 140° F. (60° C.) are expected.
- **FILTRATION** - Fluid cleanliness per ISO/DIS 4406 should be 18/15 or better for pressures of 2000 psi (140 bar) or less. For continuous operating pressures of 2000 to 3000 psi (140 to 210 bar), fluid cleanliness should be 17/13 or better.

PVX-20 VANE PUMPS



VARIABLE DISPLACEMENT, PRESSURE COMPENSATED

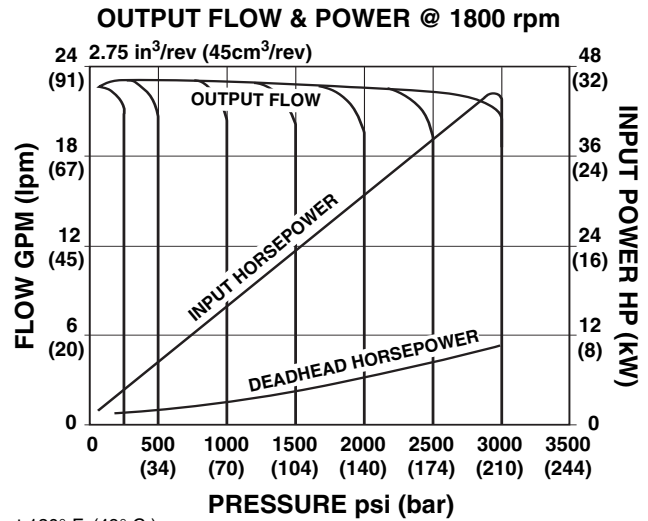
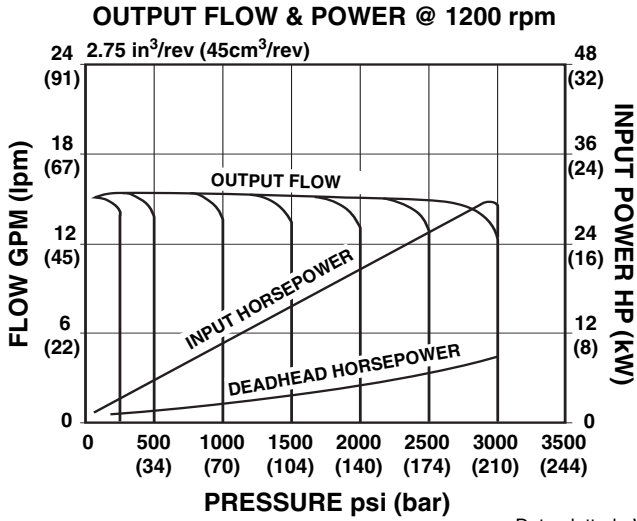

Data plotted: With oil at 120° F. (49° C.).
Viscosity @ 120° F. (49° C.) = 140 SUS.

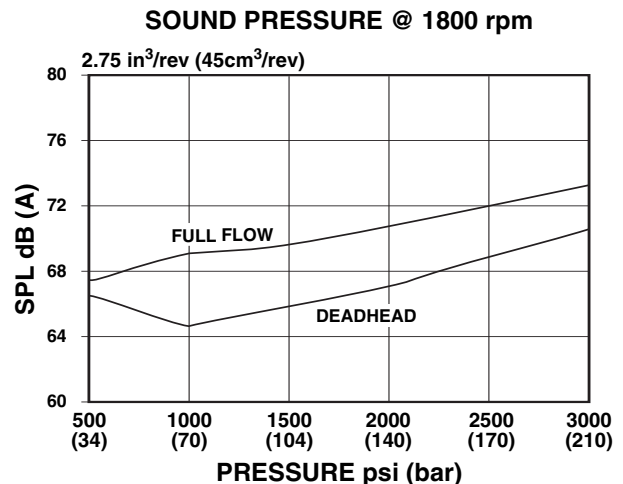
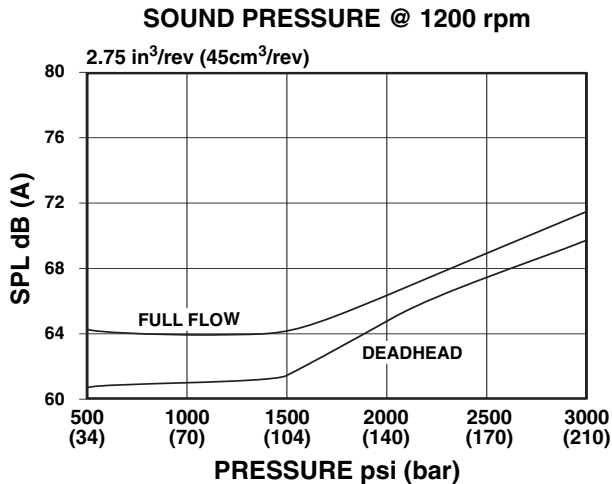
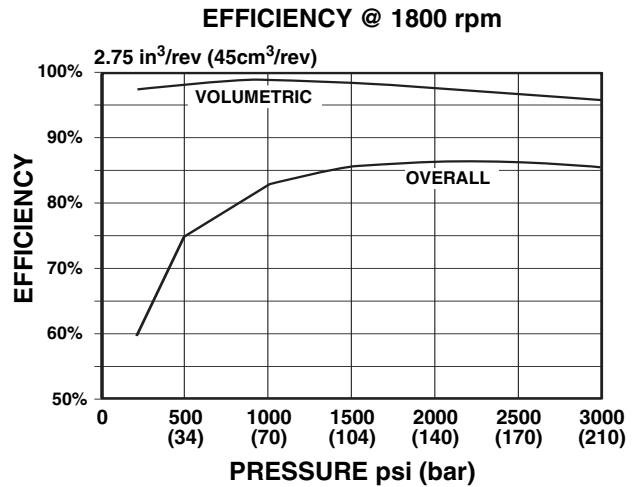
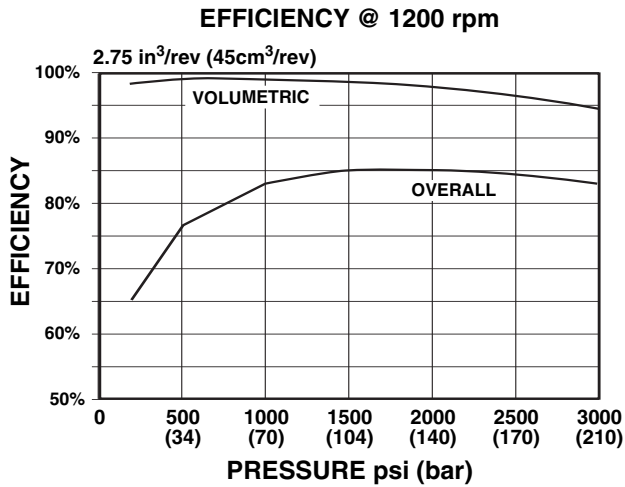

Sound pressure levels measured in a hemi-anechoic chamber with microphone placed one (1) meter away at discrete locations. Sound pressure levels are spatially and time-weighted averaged.

PVX-29 VANE PUMPS

VARIABLE DISPLACEMENT, PRESSURE COMPENSATED



NOTE: See pages 22 and 23 for PVX-29 dimensions.

PERFORMANCE SPECIFICATIONS

Displacement (Nominal)	3.84 in ³ /rev. (63 cm ³ /rev.)
Displacement (Actual)	3.93 in ³ /rev. (64.4 cm ³ /rev.)
Flow at 1750 rpm*	29.10 gpm (110.1 l/min.)
Maximum continuous pressure	3000 psi (210 bar)
Pressure compensating range	Two stage 350-3000 psi (24-210 bar) Minimum 300 psi (21 bar)
Maximum transient spike pressure	4000 psi (280 bar)
Maximum case pressure	10 psi (0.7 bar)
Speed range	1150 - 1800 rpm
Direction of rotation (viewed shaft end)	Right hand (clockwise)
Case drain flow	1000 psi (70 bar) 1.4 gpm (5.3 l/min.) while compensating 2000 psi (140 bar) 1.8 gpm (6.8 l/min.) at 1800 rpm 3000 psi (210 bar) 2.4 gpm (9.1 l/min.)
Maximum inlet vacuum at sea level	6 inches Hg (152 mm Hg)
Mounting - SAE 2 bolt flange (ISO 3019/1)	S.A.E 'C' - 2 bolt flange
Mounting position	Unrestricted
Port sizes	Inlet 2" S.A.E.
	Outlet 1-1/4" S.A.E.
	Case drain #8 S.A.E.
	Remote control (optional) #4 S.A.E.
Fluid viscosity at operating temperature	Minimum 150 SUS (32 cSt)
	Maximum 1000 SUS (216 cSt)
	Optimum 200-300 SUS (43-65 cSt)
	Maximum start-up 4000 SUS (864 cSt)
Seals	Standard fluorocarbon

Response time (Circuit dependent)	Full flow to minimum flow	20-40 ms
Response time (Circuit dependent)	Minimum flow to full flow	100-250 ms - two stage compensator
Weight	Single stage	120 lbs. (55 kg)
	Two stage	128 lbs. (58 kg)

* Flows are actual. Volumetric efficiencies shown in technical data are taken into account.

OTHER SPECIFICATIONS

- DRIVE** - Pump to be connected to prime mover by means of a flexible coupling that is aligned to a maximum of .006" (.152 mm) total indicator reading. No overhung or side loads permitted. Alignments greater than .006" (.152 mm) indicator reading could cause increased noise and vibration as well as premature shaft seal wear resulting in leakage.
- FLUID RECOMMENDATIONS** - A premium quality hydraulic oil with anti-wear additives is recommended, but not required. Consult factory for use with water base fire resistant fluids.
- FLUID TEMPERATURE** - Normal inlet fluid temperature should not exceed 140° F. (60° C.). Always select a fluid for optimum viscosity at operating temperature. Consult factory for applications assistance when inlet fluid temperatures over 140° F. (60° C.) are expected.
- FILTRATION** - Fluid cleanliness per ISO/DIS 4406 should be 18/15 or better for pressures of 2000 psi (140 bar) or less. For continuous operating pressures of 2000 to 3000 psi (140 to 210 bar), fluid cleanliness should be 17/13 or better.

PVX-29 VANE PUMPS



VARIABLE DISPLACEMENT, PRESSURE COMPENSATED

OUTPUT FLOW & POWER @ 1200 rpm

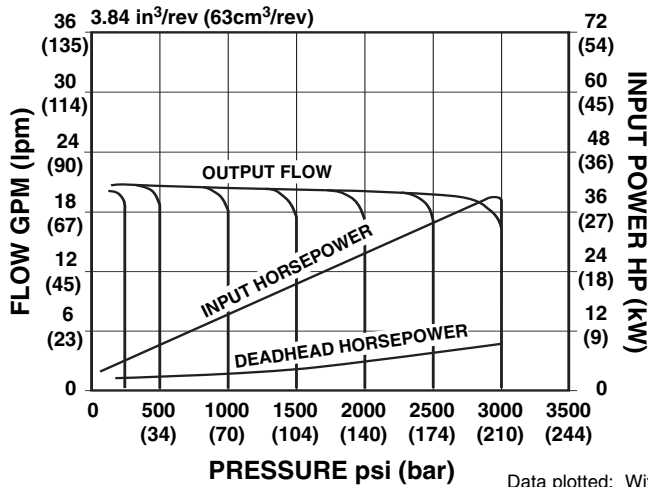

OUTPUT FLOW & POWER @ 1800 rpm

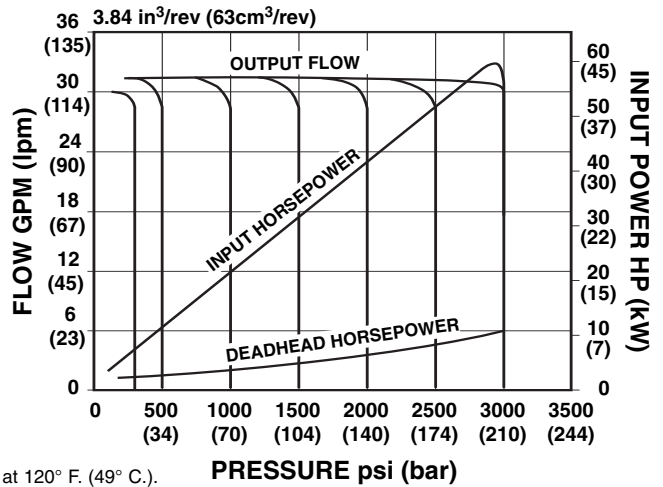

Data plotted: With oil at 120° F. (49° C.).
Viscosity @ 120° F. (49° C.) = 140 SUS.

EFFICIENCY @ 1200 rpm

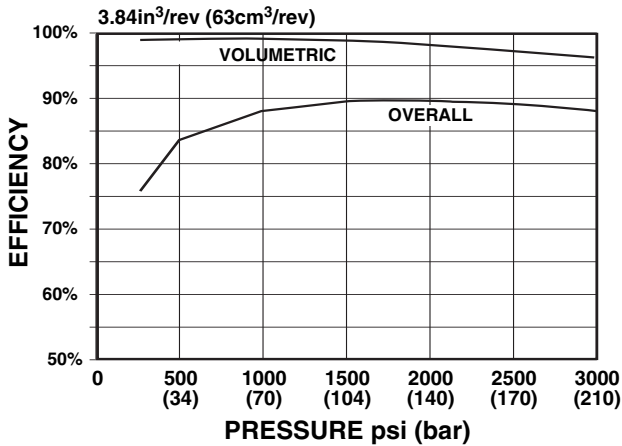

EFFICIENCY @ 1800 rpm

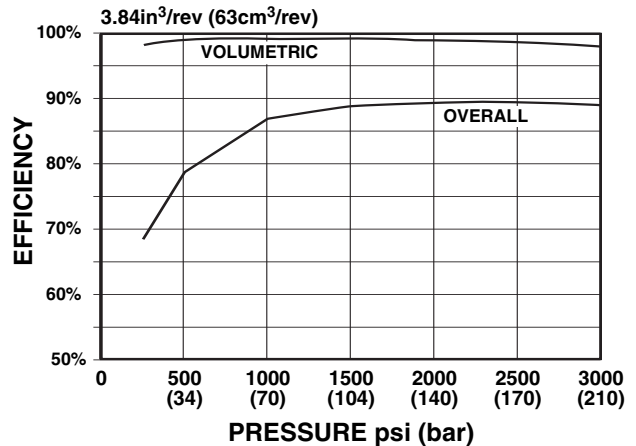

SOUND PRESSURE @ 1200 rpm

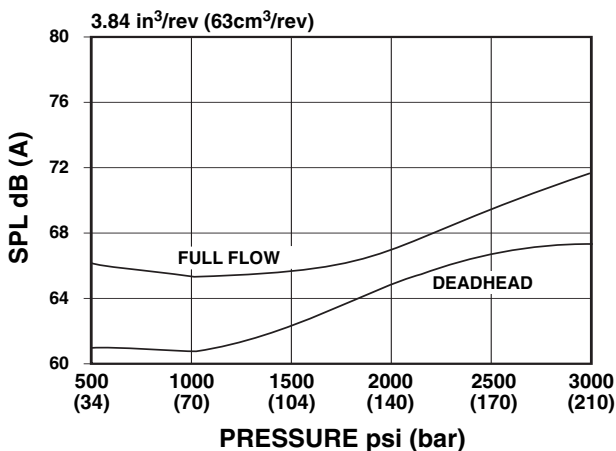

SOUND PRESSURE @ 1800 rpm

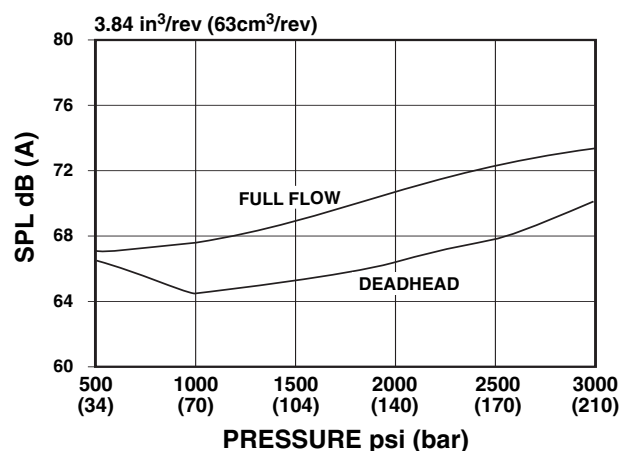

Sound pressure levels measured in a hemi-anechoic chamber with microphone placed one (1) meter away at discrete locations. Sound pressure levels are spatially and time-weighted averaged.

PVX-36 VANE PUMPS

VARIABLE DISPLACEMENT, PRESSURE COMPENSATED



NOTE: See pages 22 and 23 for PVX-36 dimensions.

PERFORMANCE SPECIFICATIONS

Displacement (Nominal)	4.88 in ³ /rev. (80 cm ³ /rev.)
Displacement (Actual)	5.02 in ³ /rev. (82.3 cm ³ /rev.)
Flow at 1750 rpm*	36.97 gpm (139.9 l/min.)
Maximum continuous pressure	3000 psi (210 bar)
Pressure compensating range	Two stage 350-3000 psi (24-210 bar) Minimum 300 psi (21 bar)
Maximum transient spike pressure	4000 psi (280 bar)
Maximum case pressure	10 psi (0.7 bar)
Speed range	1150 - 1800 rpm
Direction of rotation (viewed shaft end)	Right hand (clockwise)
Case drain flow	1000 psi (70 bar) 1.4 gpm (5.3 l/min.) while compensating 2000 psi (140 bar) 1.8 gpm (6.8 l/min.) at 1800 rpm 3000 psi (210 bar) 2.3 gpm (8.7 l/min.)
Maximum inlet vacuum at sea level	6 inches Hg (152 mm Hg)
Mounting - SAE 2 bolt flange (ISO 3019/1)	S.A.E 'C' - 2 bolt flange
Mounting position	Unrestricted
Port sizes	Inlet 2" S.A.E.
	Outlet 1-1/4" S.A.E.
	Case drain #8 S.A.E.
	Remote control (optional) #4 S.A.E.
Fluid viscosity at operating temperature	Minimum 150 SUS (32 cSt)
	Maximum 1000 SUS (216 cSt)
	Optimum 200-300 SUS (43-65 cSt)
	Maximum start-up 4000 SUS (864 cSt)
Seals	Standard fluorocarbon

Response time (Circuit dependent)	Full flow to minimum flow	20-40 ms
Response time (Circuit dependent)	Minimum flow to full flow	100-250 ms - two stage compensator
Weight	Single stage	120 lbs. (55 kg)
	Two stage	128 lbs. (58 kg)

* Flows are actual. Volumetric efficiencies shown in technical data are taken into account.

OTHER SPECIFICATIONS

- **DRIVE** - Pump to be connected to prime mover by means of a flexible coupling that is aligned to a maximum of .006" (.152 mm) total indicator reading. No overhung or side loads permitted. Alignments greater than .006" (.152 mm) indicator reading could cause increased noise and vibration as well as premature shaft seal wear resulting in leakage.
- **FLUID RECOMMENDATIONS** - A premium quality hydraulic oil with anti-wear additives is recommended, but not required. Consult factory for use with water base fire resistant fluids.
- **FLUID TEMPERATURE** - Normal inlet fluid temperature should not exceed 140° F. (60° C.). Always select a fluid for optimum viscosity at operating temperature. Consult factory for applications assistance when inlet fluid temperatures over 140° F. (60° C.) are expected.
- **FILTRATION** - Fluid cleanliness per ISO/DIS 4406 should be 18/15 or better for pressures of 2000 psi (140 bar) or less. For continuous operating pressures of 2000 to 3000 psi (140 to 210 bar), fluid cleanliness should be 17/13 or better.

PVX-36 VANE PUMPS



VARIABLE DISPLACEMENT, PRESSURE COMPENSATED

OUTPUT FLOW & POWER @ 1200 rpm

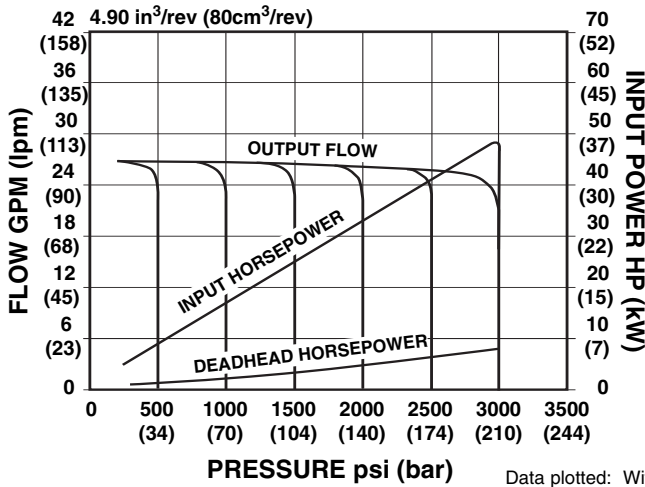

OUTPUT FLOW & POWER @ 1800 rpm

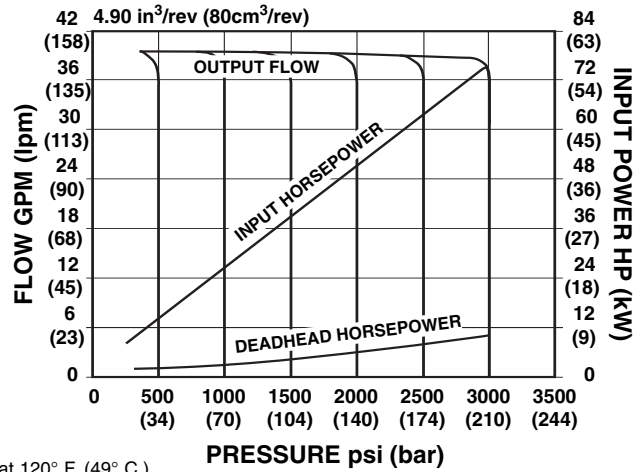

Data plotted: With oil at 120° F. (49° C.).
Viscosity @ 120° F. (49° C.) = 140 SUS.

EFFICIENCY @ 1200 rpm

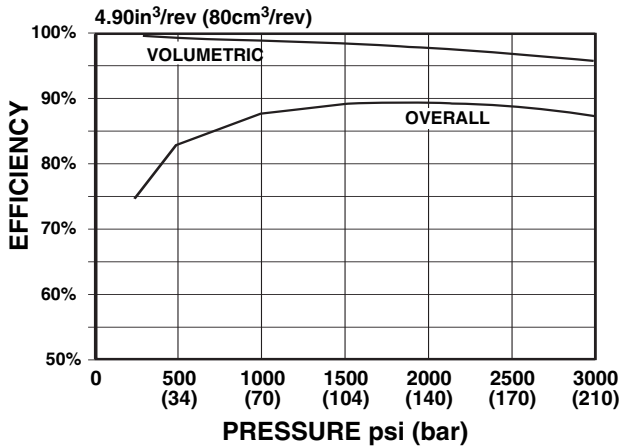

EFFICIENCY @ 1800 rpm

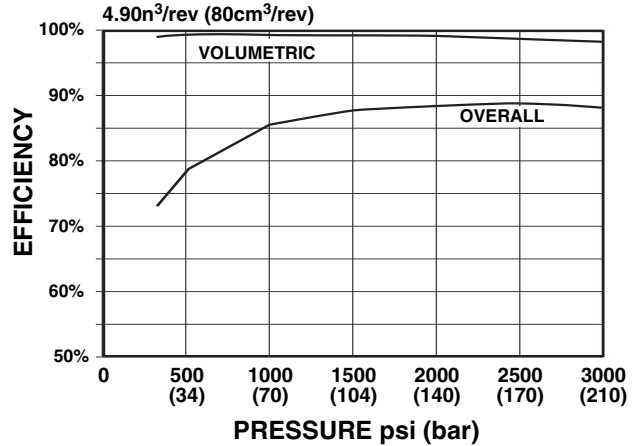

SOUND PRESSURE @ 1200 rpm

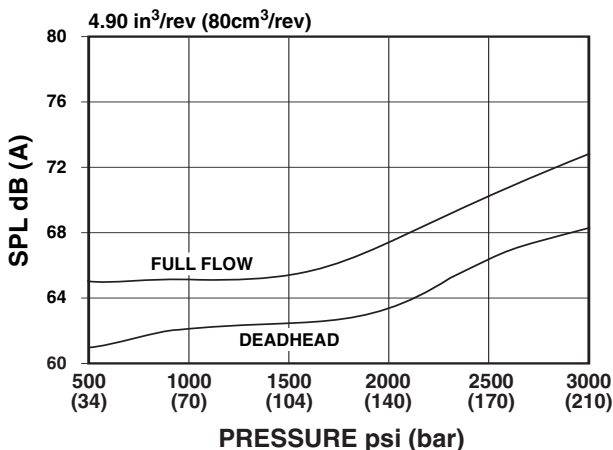

SOUND PRESSURE @ 1800 rpm

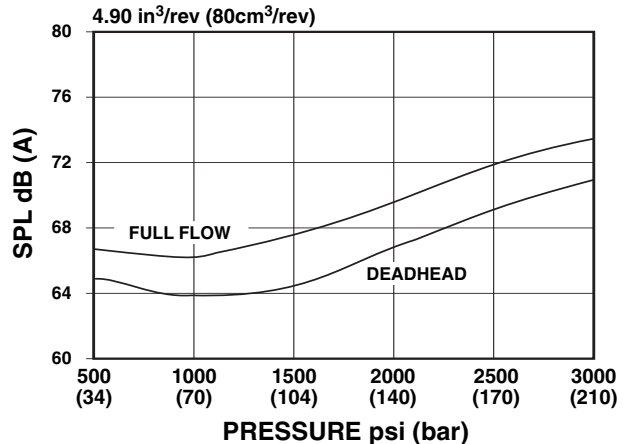

Sound pressure levels measured in a hemi-anechoic chamber with microphone placed one (1) meter away at discrete locations. Sound pressure levels are spatially and time-weighted averaged.

PVX-20/29/36 VANE PUMPS

VARIABLE DISPLACEMENT, PRESSURE COMPENSATED

S.A.E. 'C' Flange, RH Rotation

INCHES
(millimeters)

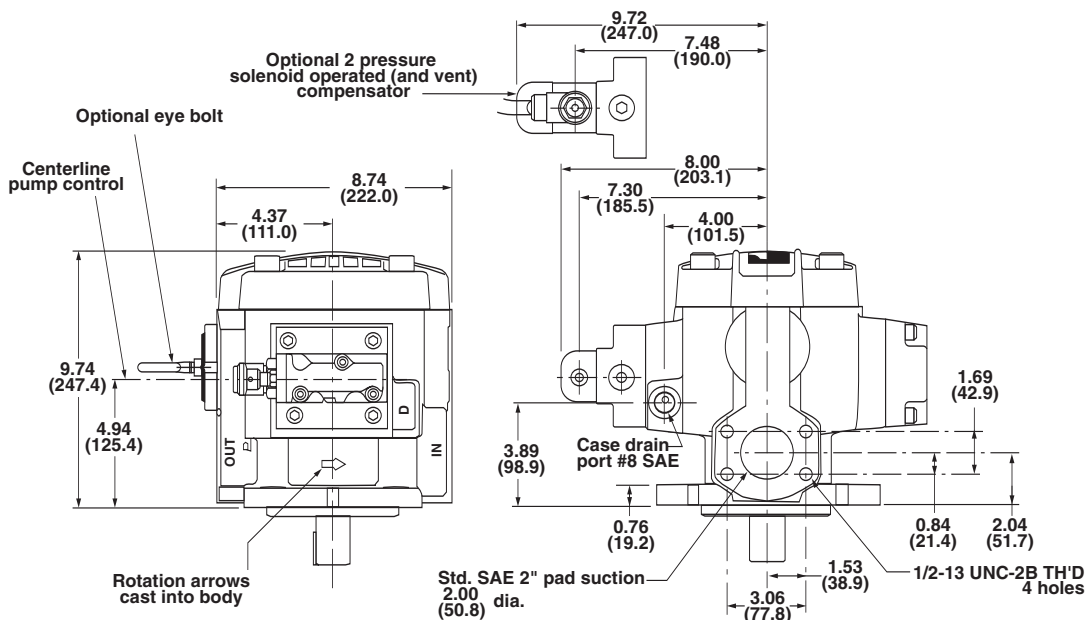

SCALE: 2X

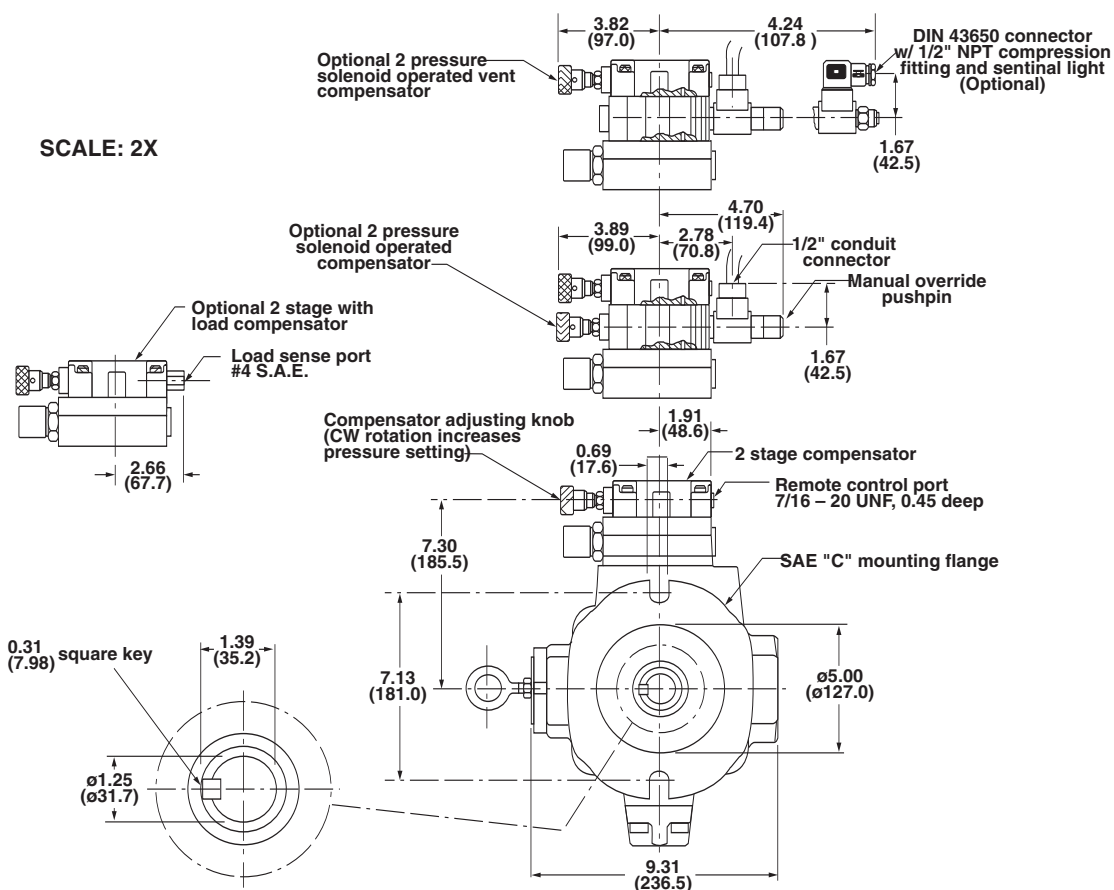

PVX-20/29/36 VANE PUMPS

VARIABLE DISPLACEMENT, PRESSURE COMPENSATED

S.A.E. 'C' Flange, RH Rotation

INCHES
(millimeters)

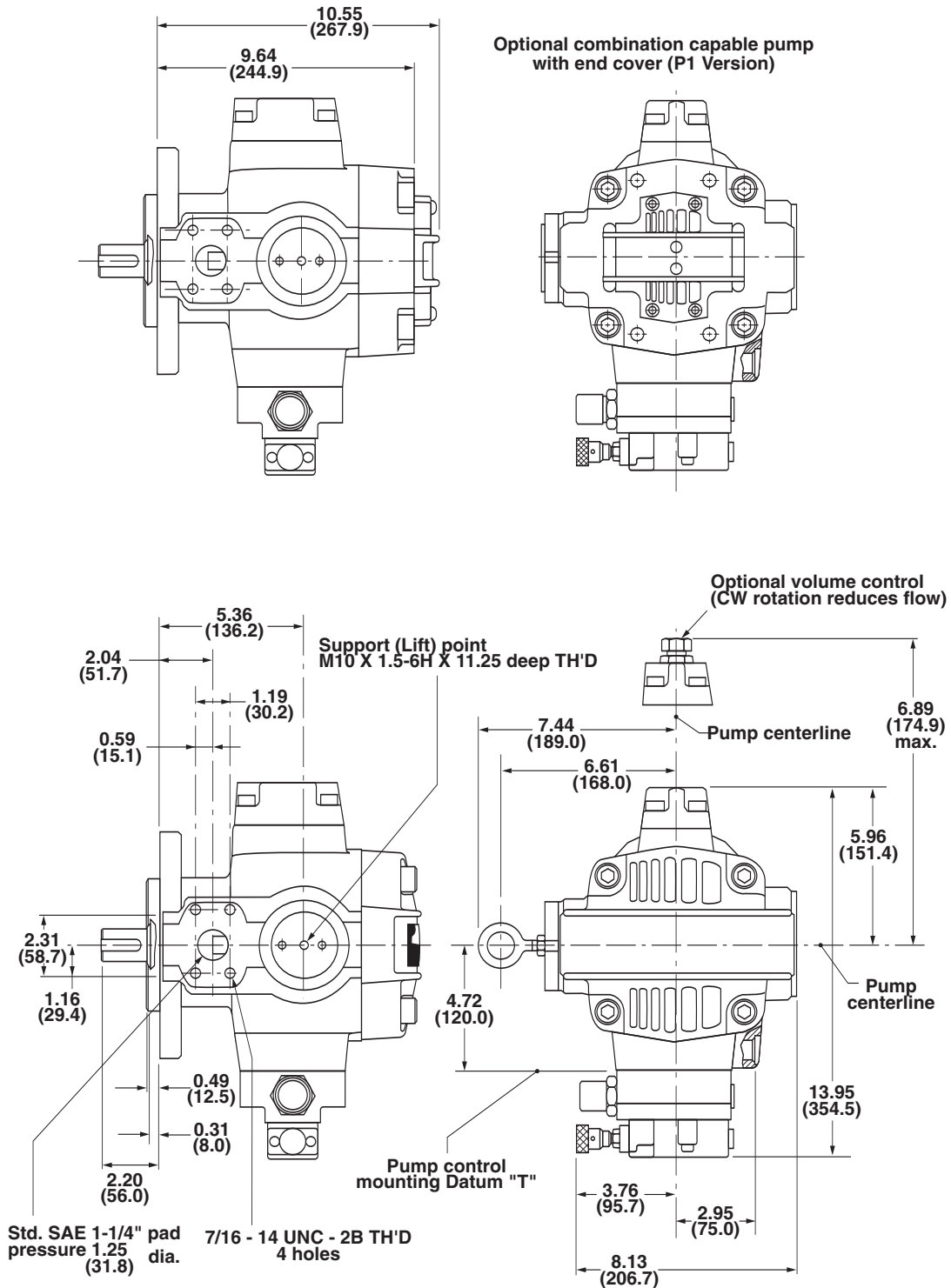

PVX-20/29/36 VANE PUMPS

VARIABLE DISPLACEMENT, PRESSURE COMPENSATED

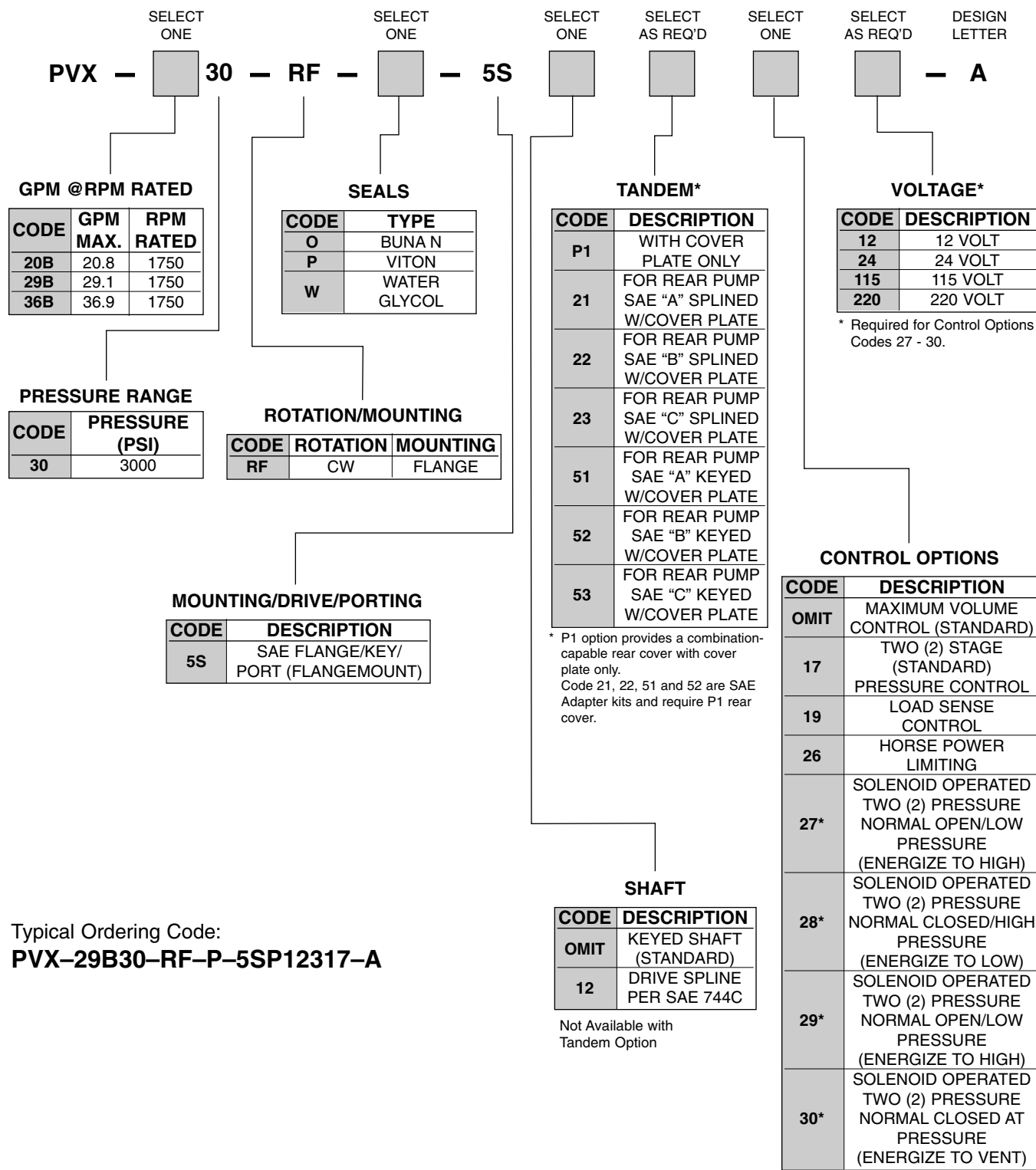

Typical Ordering Code:
PVX-29B30-RF-P-5SP12317-A

* Required for Control Options Codes 27 - 30.

* P1 option provides a combination-capable rear cover with cover plate only. Code 21, 22, 51 and 52 are SAE Adapter kits and require P1 rear cover.

* Requires voltage selection.

PVX-46 VANE PUMPS

VARIABLE DISPLACEMENT, PRESSURE COMPENSATED



NOTE: See pages 31 and 32 for PVX-46 dimensions.

PERFORMANCE SPECIFICATIONS

Displacement (Nominal)	6.1 in ³ /rev. (100 cm ³ /rev.)
Displacement (Actual)	6.0 in ³ /rev. (99 cm ³ /rev.)
Flow at 1750 rpm*	45.4 gpm (171.8 l/min.)
Maximum pressure	2500 psi (170 bar)
Maximum pressure - high cycle applications	2500 psi (170 bar)
Pressure compensating range	Two stage 350-2500 psi (24-170 bar)
Maximum transient spike pressure	4000 psi (280 bar)
Maximum case pressure	10 psi (0.7 bar)
Speed range	1150 - 1800 rpm
Direction of rotation (viewed shaft end)	Right hand (clockwise)
Case drain flow	1000 psi (70 bar) 1.5 gpm (5.7 l/min.)
while compensating	2000 psi (140 bar) 2.0 gpm (7.6 l/min.)
at 1800 rpm	3000 psi (210 bar) 2.5 gpm (9.5 l/min.)
Maximum inlet vacuum at sea level	6 inches Hg (152 mm Hg)
Mounting - SAE 2 bolt flange (ISO 3019/1)	S.A.E 'D' - 2 bolt flange
Mounting position	Unrestricted
Port sizes	Inlet 2-1/2" S.A.E.
	Outlet 1-1/2" S.A.E.
	Case drain #8 S.A.E.
	Remote control (optional) #4 S.A.E.
Fluid viscosity at operating temperature	Minimum 150 SUS (32 cSt)
	Maximum 1000 SUS (216 cSt)
	Optimum 200-300 SUS (43-65 cSt)
	Maximum start-up 4000 SUS (864 cSt)
Seals	Standard fluorocarbon

Response time (Circuit dependent)	Full flow to minimum flow	20-50 ms
Response time (Circuit dependent)	Minimum flow to full flow	250 - 500 ms - two stage compensator
Weight	Single stage	240 lbs. (109 kg)
	Two stage	248 lbs. (112.7 kg)

* Flows are actual. Volumetric efficiencies shown in technical data are taken into account.

OTHER SPECIFICATIONS

• **DRIVE** - Pump to be connected to prime mover by means of a flexible coupling that is aligned to a maximum of .006" (.152 mm) total indicator reading. No overhung or side loads permitted. Alignments greater than .006" (.152 mm) indicator reading could cause increased noise and vibration as well as premature shaft seal wear resulting in leakage.

• **FLUID RECOMMENDATIONS** - A premium quality hydraulic oil with anti-wear additives is required.* Consult factory for use with water base fire resistant fluids.

* Such as Mobil DTE-26, or similar, for pressures over 2000 psi (140 bar).

• **FLUID TEMPERATURE** - Normal inlet fluid temperature should not exceed 140° F. (60° C.). Always select a fluid for optimum viscosity at operating temperature. Consult factory for applications assistance when inlet fluid temperatures over 140° F. (60° C.) are expected.

• **FILTRATION** - Fluid cleanliness per ISO/DIS 4406 should be 18/15 or better for pressures of 2000 psi (140 bar) or less. For continuous operating pressures of 2000 to 3000 psi (140 to 210 bar), fluid cleanliness should be 17/13 or better.

PVX-46 VANE PUMPS

VARIABLE DISPLACEMENT, PRESSURE COMPENSATED

OUTPUT FLOW & POWER @ 1200 rpm

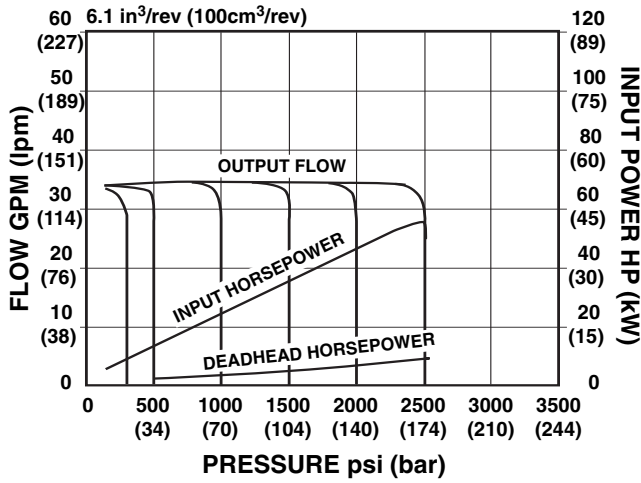

OUTPUT FLOW & POWER @ 1800 rpm

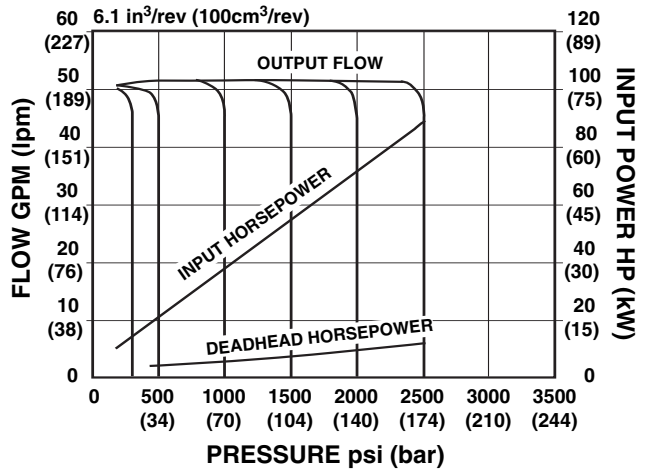

EFFICIENCY @ 1200 rpm

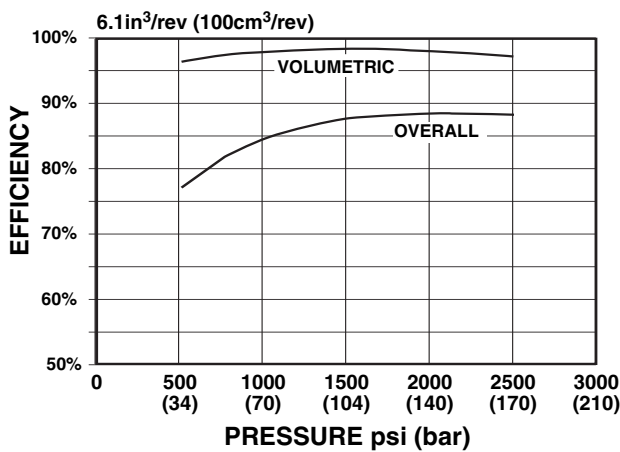

EFFICIENCY @ 1800 rpm

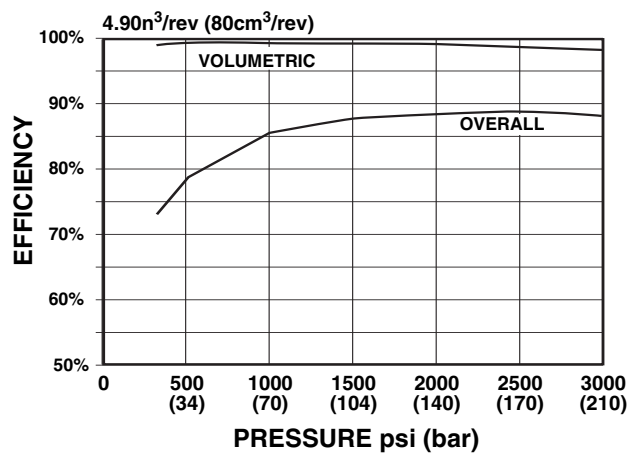

SOUND PRESSURE @ 1200 rpm

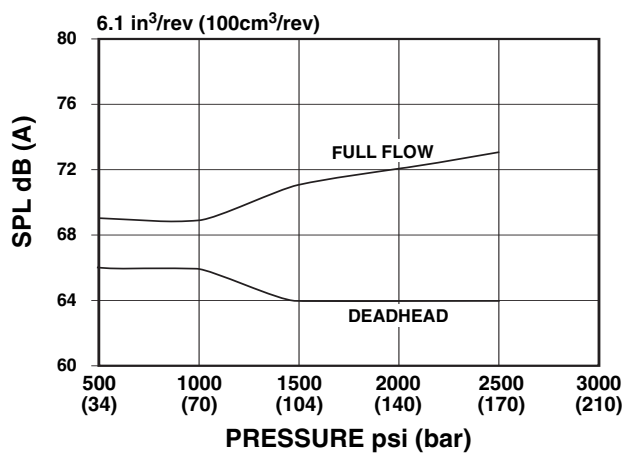

SOUND PRESSURE @ 1800 rpm

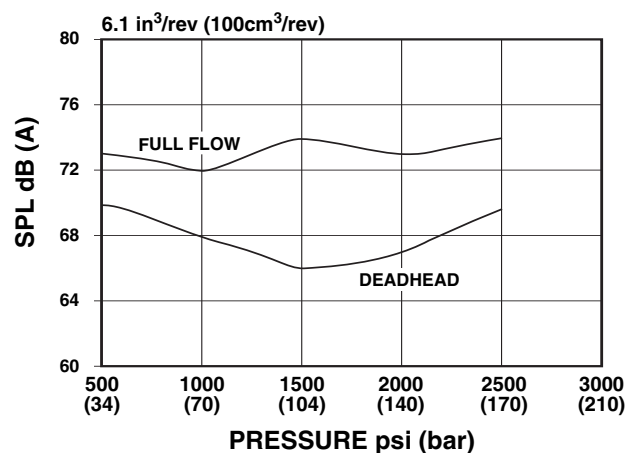

Sound pressure levels measured in a hemi-anechoic chamber with microphone placed one (1) meter away at discrete locations. Sound pressure levels are spatially and time-weighted averaged.

PVX-60 VANE PUMPS



VARIABLE DISPLACEMENT, PRESSURE COMPENSATED



NOTE: See pages 31 and 32 for PVX-60 dimensions.

PERFORMANCE SPECIFICATIONS

Displacement (Nominal)	7.9 in ³ /rev. (130 cm ³ /rev.)
Displacement (Actual)	8.0 in ³ /rev. (131 cm ³ /rev.)
Flow at 1750 rpm*	59.85 gpm (226.5 l/min.)
Maximum pressure	2500 psi (170 bar)
Maximum pressure - high cycle applications	2500 psi (170 bar)
Pressure compensating range	Two stage 350-2500 psi (24-170 bar)
Maximum transient spike pressure	4000 psi (280 bar)
Maximum case pressure	10 psi (0.7 bar)
Speed range	1150 - 1800 rpm
Direction of rotation (viewed shaft end)	Right hand (clockwise)
Case drain flow	1000 psi (70 bar) 1.6 gpm (6.0 l/min.)
while compensating	2000 psi (140 bar) 2.2 gpm (8.3 l/min.)
at 1800 rpm	3000 psi (210 bar) 3.0 gpm (11.3 l/min.)
Maximum inlet vacuum at sea level	6 inches Hg (152 mm Hg)
Mounting - SAE 2 bolt flange (ISO 3019/1)	S.A.E 'D' - 2 bolt flange
Mounting position	Unrestricted
Port sizes	Inlet 2-1/2" S.A.E.
	Outlet 1-1/2" S.A.E.
	Case drain #8 S.A.E.
	Remote control (optional) #4 S.A.E.
Fluid viscosity at operating temperature	Minimum 150 SUS (32 cSt)
	Maximum 1000 SUS (216 cSt)
	Optimum 200-300 SUS (43-65 cSt)
	Maximum start-up 4000 SUS (864 cSt)
Seals	Standard fluorocarbon

Response time (Circuit dependent)	Full flow to minimum flow	20-50 ms
Response time (Circuit dependent)	Minimum flow to full flow	250 - 500 ms - two stage compensator
Weight	Single stage	240 lbs. (109 kg)
	Two stage	248 lbs. (112.7 kg)

* Flows are actual. Volumetric efficiencies shown in technical data are taken into account.

OTHER SPECIFICATIONS

• **DRIVE** - Pump to be connected to prime mover by means of a flexible coupling that is aligned to a maximum of .006" (.152 mm) total indicator reading. No overhung or side loads permitted. Alignments greater than .006" (.152 mm) indicator reading could cause increased noise and vibration as well as premature shaft seal wear resulting in leakage.

• **FLUID RECOMMENDATIONS** - A premium quality hydraulic oil with anti-wear additives is required.* Consult factory for use with water base fire resistant fluids.

* Such as Mobil DTE-26, or similar, for pressures over 2000 psi (140 bar).

• **FLUID TEMPERATURE** - Normal inlet fluid temperature should not exceed 140° F. (60° C.). Always select a fluid for optimum viscosity at operating temperature. Consult factory for applications assistance when inlet fluid temperatures over 140° F. (60° C.) are expected.

• **FILTRATION** - Fluid cleanliness per ISO/DIS 4406 should be 18/15 or better for pressures of 2000 psi (140 bar) or less. For continuous operating pressures of 2000 to 3000 psi (140 to 210 bar), fluid cleanliness should be 17/13 or better.

PVX-60 VANE PUMPS

VARIABLE DISPLACEMENT, PRESSURE COMPENSATED

OUTPUT FLOW & POWER @ 1200 rpm

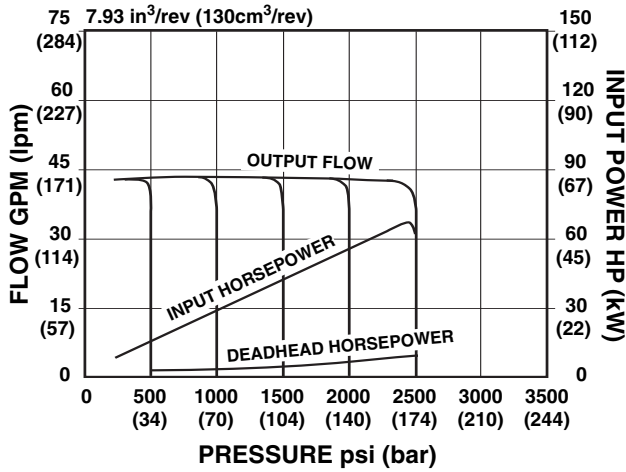

OUTPUT FLOW & POWER @ 1800 rpm

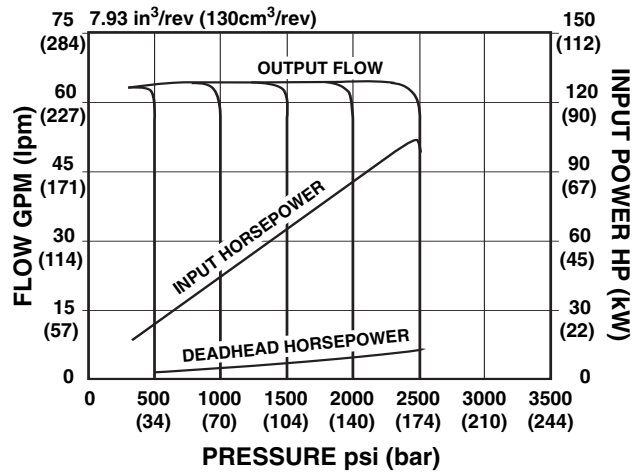

EFFICIENCY @ 1200 rpm

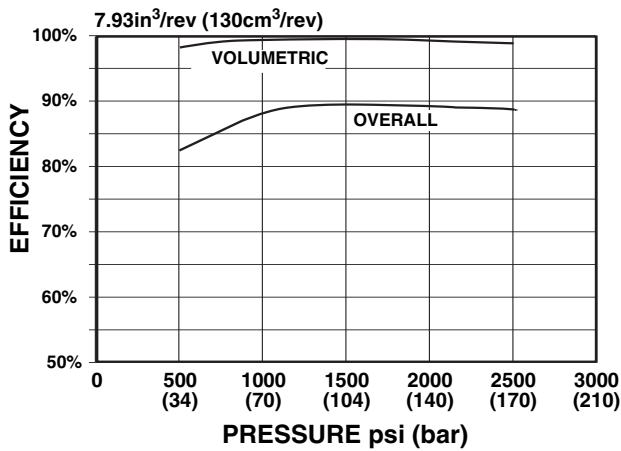

EFFICIENCY @ 1800 rpm

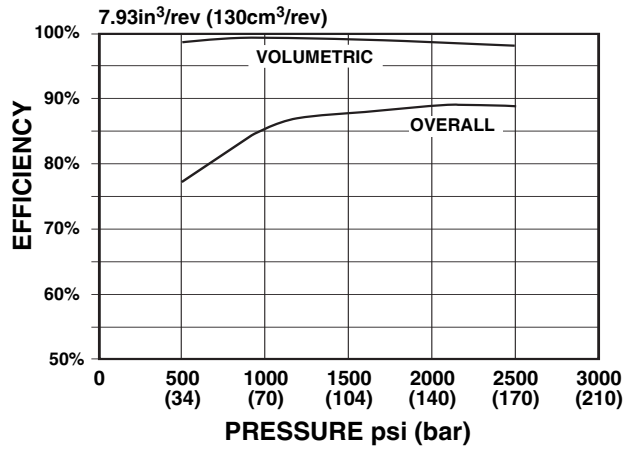

SOUND PRESSURE @ 1200 rpm

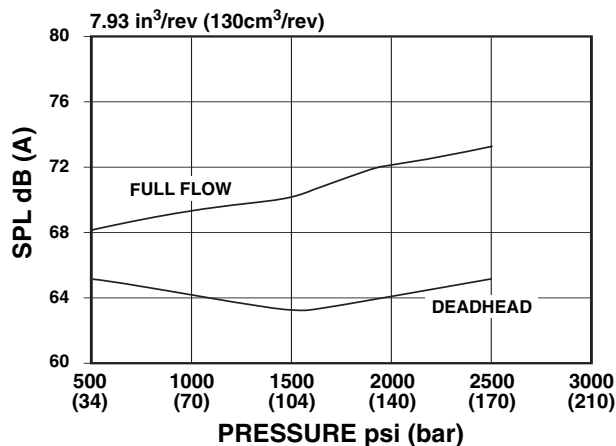

SOUND PRESSURE @ 1800 rpm

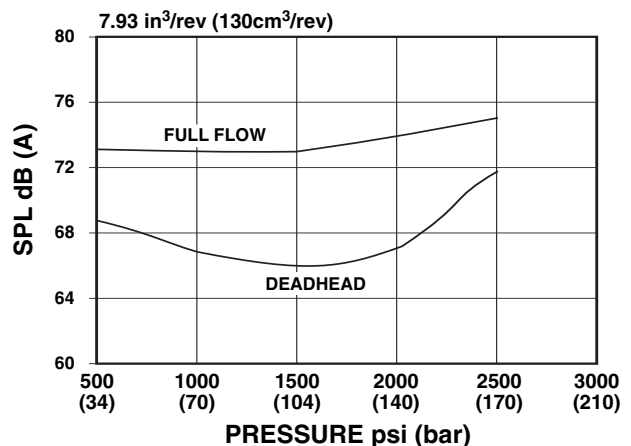

Sound pressure levels measured in a hemi-anechoic chamber with microphone placed one (1) meter away at discrete locations. Sound pressure levels are spatially and time-weighted averaged.

PVX-75 VANE PUMPS

VARIABLE DISPLACEMENT, PRESSURE COMPENSATED



NOTE: See pages 31 and 32 for PVX-75 dimensions.

PERFORMANCE SPECIFICATIONS

Displacement (Nominal)	10.0 in ³ /rev. (164 cm ³ /rev.)
Displacement (Actual)	10.0 in ³ /rev. (164 cm ³ /rev.)
Flow at 1750 rpm*	75.76 gpm (286.7 l/min.)
Maximum pressure	2500 psi (170 bar)
Maximum pressure - high cycle applications	2500 psi (170 bar)
Pressure compensating range	Two stage 350-2500 psi (24-170 bar)
Maximum transient spike pressure	4000 psi (280 bar)
Maximum case pressure	10 psi (0.7 bar)
Speed range	1150 - 1800 rpm
Direction of rotation (viewed shaft end)	Right hand (clockwise)
Case drain flow	1000 psi (70 bar) 1.7 gpm (6.4 l/min.)
while compensating	2000 psi (140 bar) 2.3 gpm (8.7 l/min.)
at 1800 rpm	3000 psi (210 bar) 3.1 gpm (11.7 l/min.)
Maximum inlet vacuum at sea level	6 inches Hg (152 mm Hg)
Mounting - SAE 2 bolt flange (ISO 3019/1)	S.A.E 'D' - 2 bolt flange
Mounting position	Unrestricted
Port sizes	Inlet 2-1/2" S.A.E.
	Outlet 1-1/2" S.A.E.
	Case drain #8 S.A.E.
	Remote control (optional) #4 S.A.E.
Fluid viscosity at operating temperature	Minimum 150 SUS (32 cSt)
	Maximum 1000 SUS (216 cSt)
	Optimum 200-300 SUS (43-65 cSt)
	Maximum start-up 4000 SUS (864 cSt)
Seals	Standard fluorocarbon

Response time (Circuit dependent)	Full flow to minimum flow	20-50 ms
Response time (Circuit dependent)	Minimum flow to full flow	250 - 500 ms - two stage compensator
Weight	Single stage	240 lbs. (109 kg)
	Two stage	248 lbs. (112.7 kg)

* Flows are actual. Volumetric efficiencies shown in technical data are taken into account.

OTHER SPECIFICATIONS

• **DRIVE** - Pump to be connected to prime mover by means of a flexible coupling that is aligned to a maximum of .006" (.152 mm) total indicator reading. No overhung or side loads permitted. Alignments greater than .006" (.152 mm) indicator reading could cause increased noise and vibration as well as premature shaft seal wear resulting in leakage.

• **FLUID RECOMMENDATIONS** - A premium quality hydraulic oil with anti-wear additives is required.* Consult factory for use with water base fire resistant fluids.

* Such as Mobil DTE-26, or similar, for pressures over 2000 psi (140 bar).

• **FLUID TEMPERATURE** - Normal inlet fluid temperature should not exceed 140° F. (60° C.). Always select a fluid for optimum viscosity at operating temperature. Consult factory for applications assistance when inlet fluid temperatures over 140° F. (60° C.) are expected.

• **FILTRATION** - Fluid cleanliness per ISO/DIS 4406 should be 18/15 or better for pressures of 2000 psi (140 bar) or less. For continuous operating pressures of 2000 to 3000 psi (140 to 210 bar), fluid cleanliness should be 17/13 or better.

PVX-75 VANE PUMPS

VARIABLE DISPLACEMENT, PRESSURE COMPENSATED

OUTPUT FLOW & POWER @ 1200 rpm

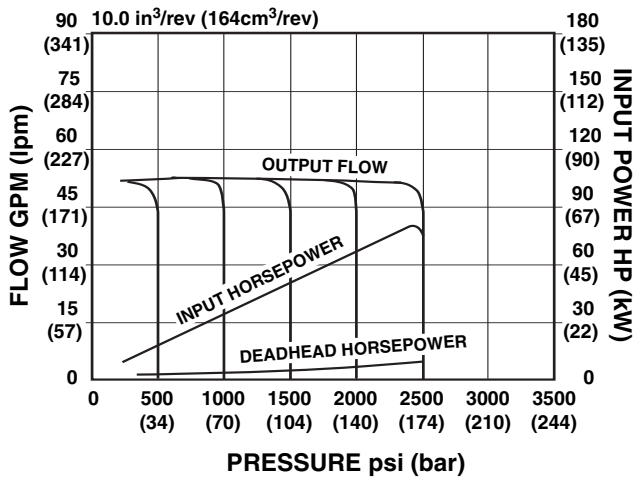

OUTPUT FLOW & POWER @ 1800 rpm

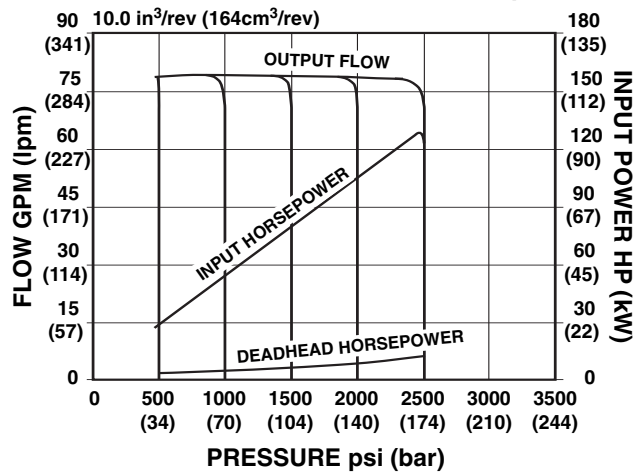

EFFICIENCY @ 1200 rpm

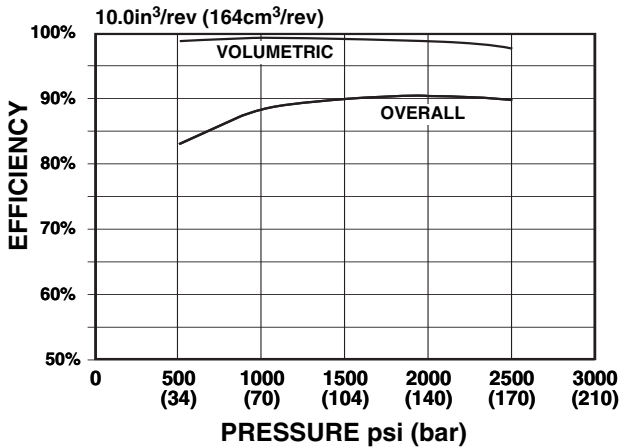

EFFICIENCY @ 1800 rpm

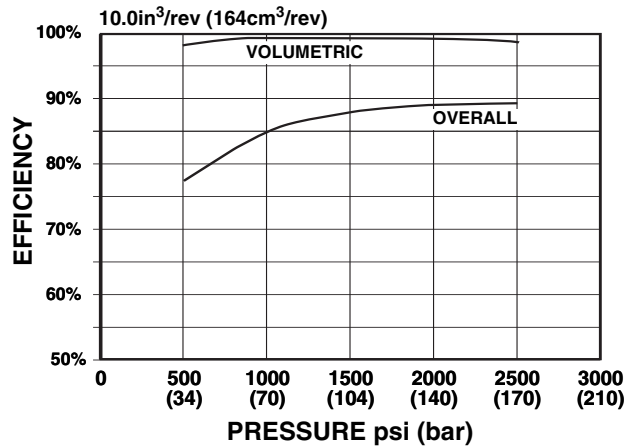

SOUND PRESSURE @ 1200 rpm

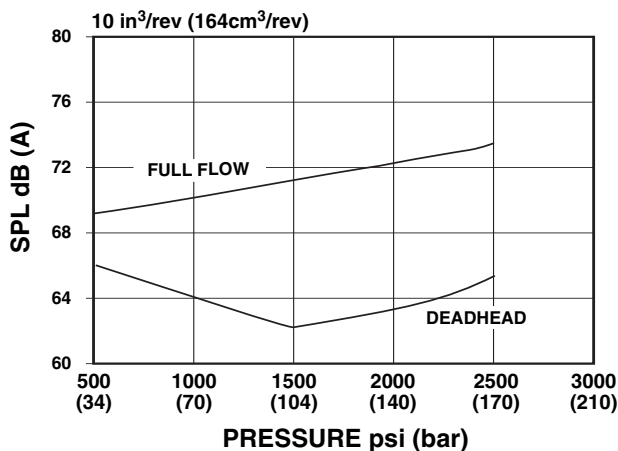

SOUND PRESSURE @ 1800 rpm

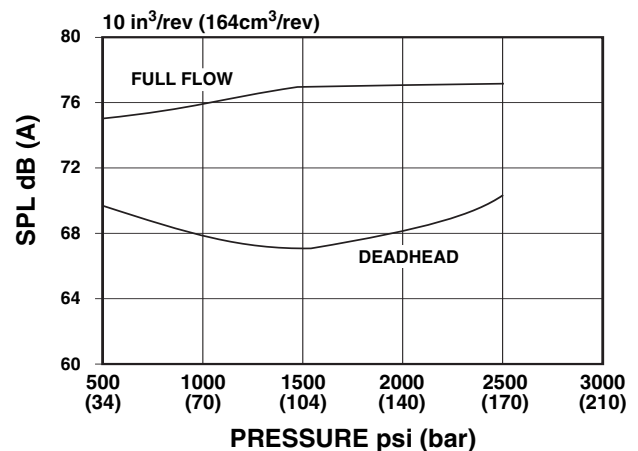

Sound pressure levels measured in a hemi-anechoic chamber with microphone placed one (1) meter away at discrete locations. Sound pressure levels are spatially and time-weighted averaged.

PVX-46/60/75 VANE PUMPS



VARIABLE DISPLACEMENT, PRESSURE COMPENSATED

S.A.E. 'D' Flange, RH Rotation

INCHES
(millimeters)

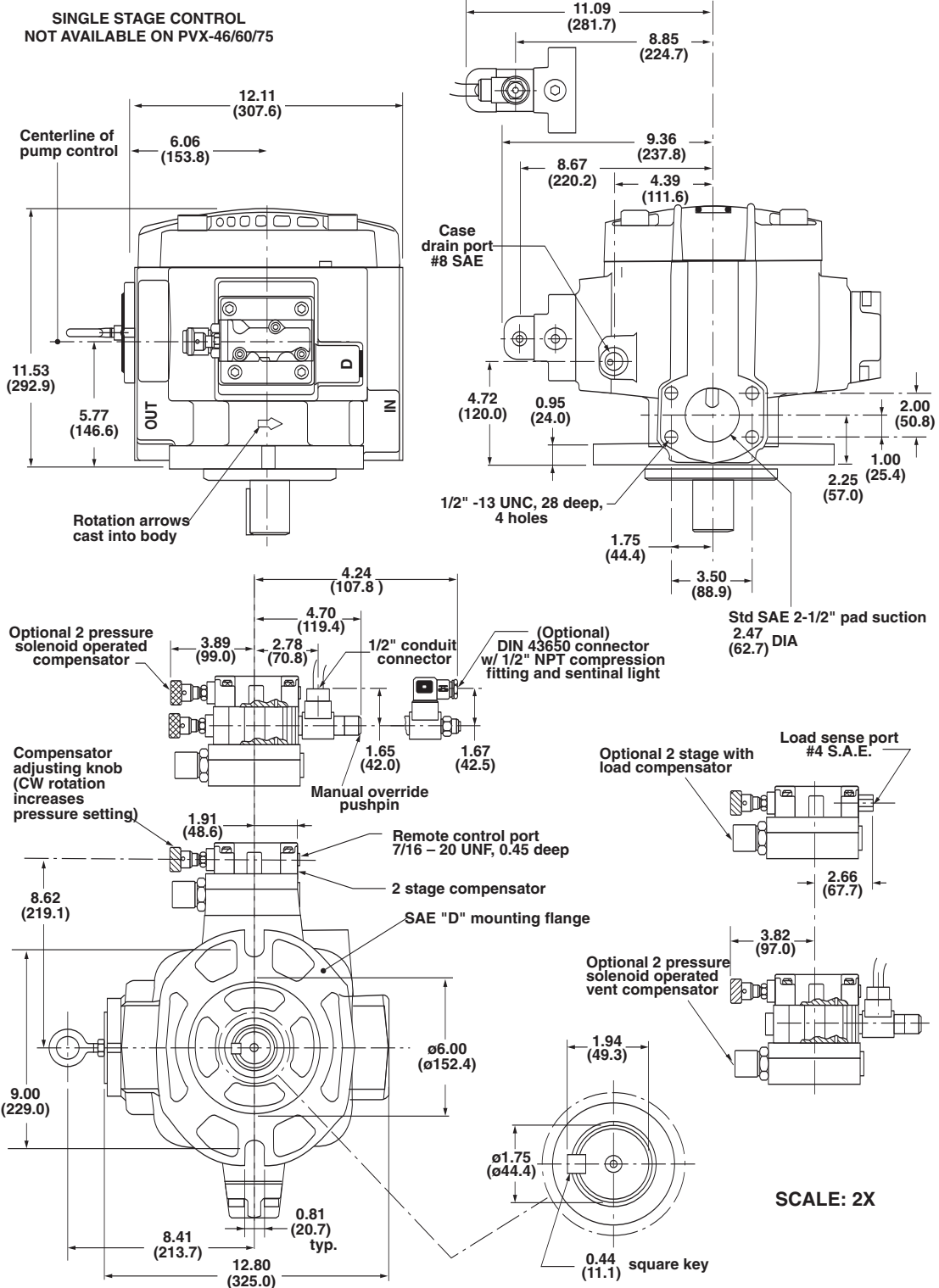

PVX-46/60/75 VANE PUMPS

VARIABLE DISPLACEMENT, PRESSURE COMPENSATED

S.A.E. 'D' Flange, RH Rotation

INCHES
(millimeters)

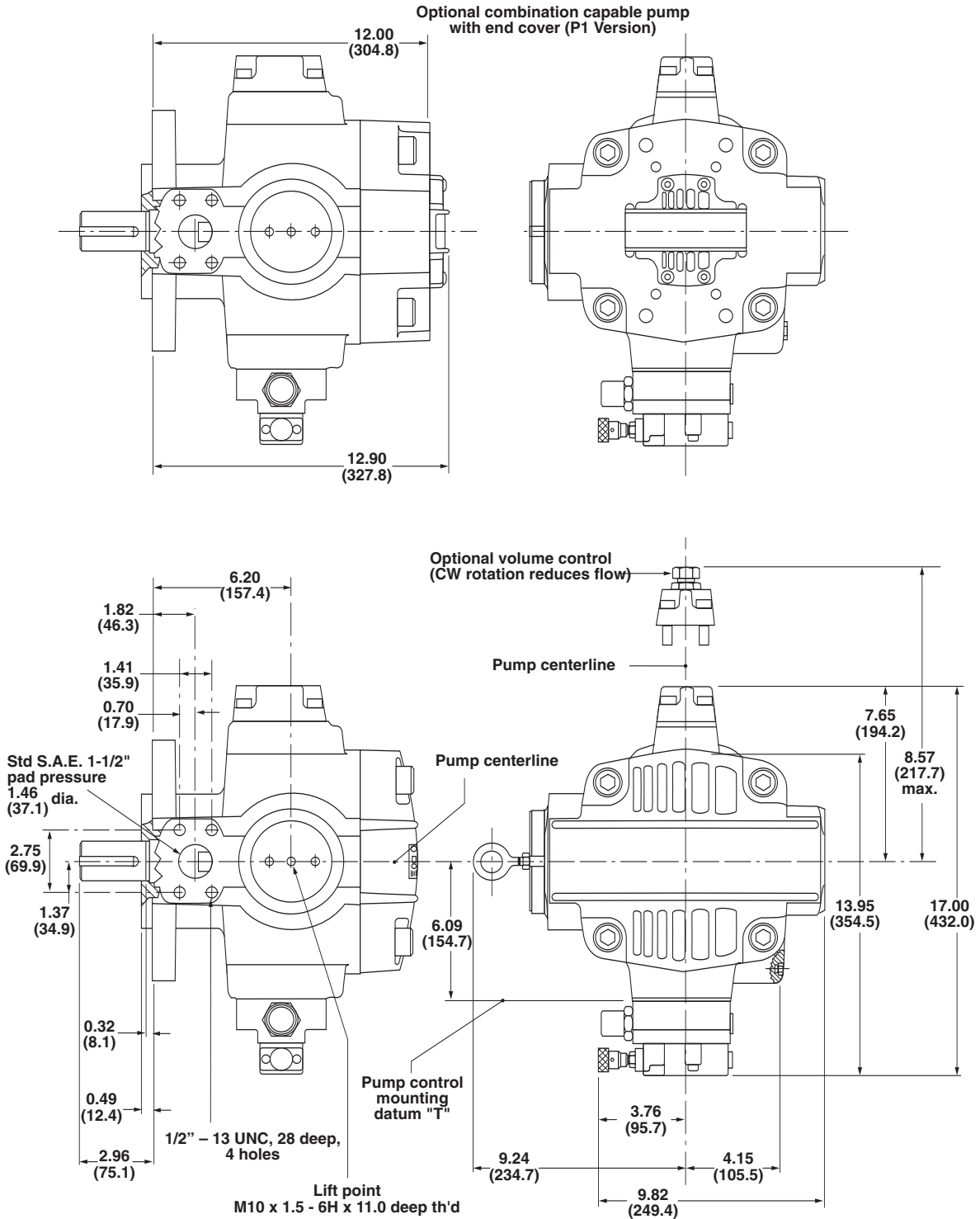

PVX-46/60/75 VANE PUMPS

VARIABLE DISPLACEMENT, PRESSURE COMPENSATED

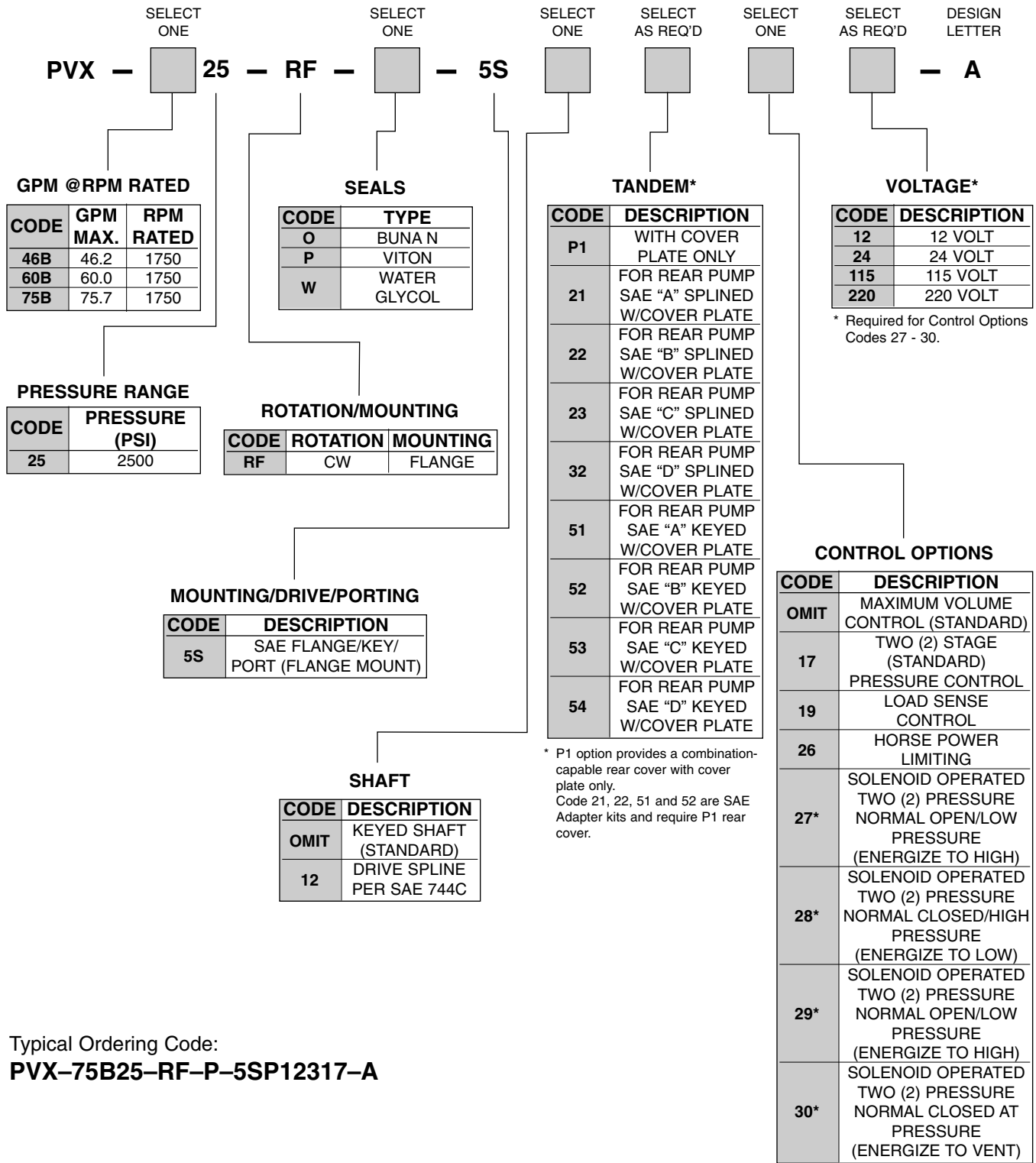

* P1 option provides a combination-capable rear cover with cover plate only. Code 21, 22, 51 and 52 are SAE Adapter kits and require P1 rear cover.

* Requires voltage selection.

Typical Ordering Code:

PVX-75B25-RF-P-5SP12317-A

PVX SERIES VANE PUMPS

ADAPTER KITS FOR PVX COMBINATIONS USING "P1" PUMPS

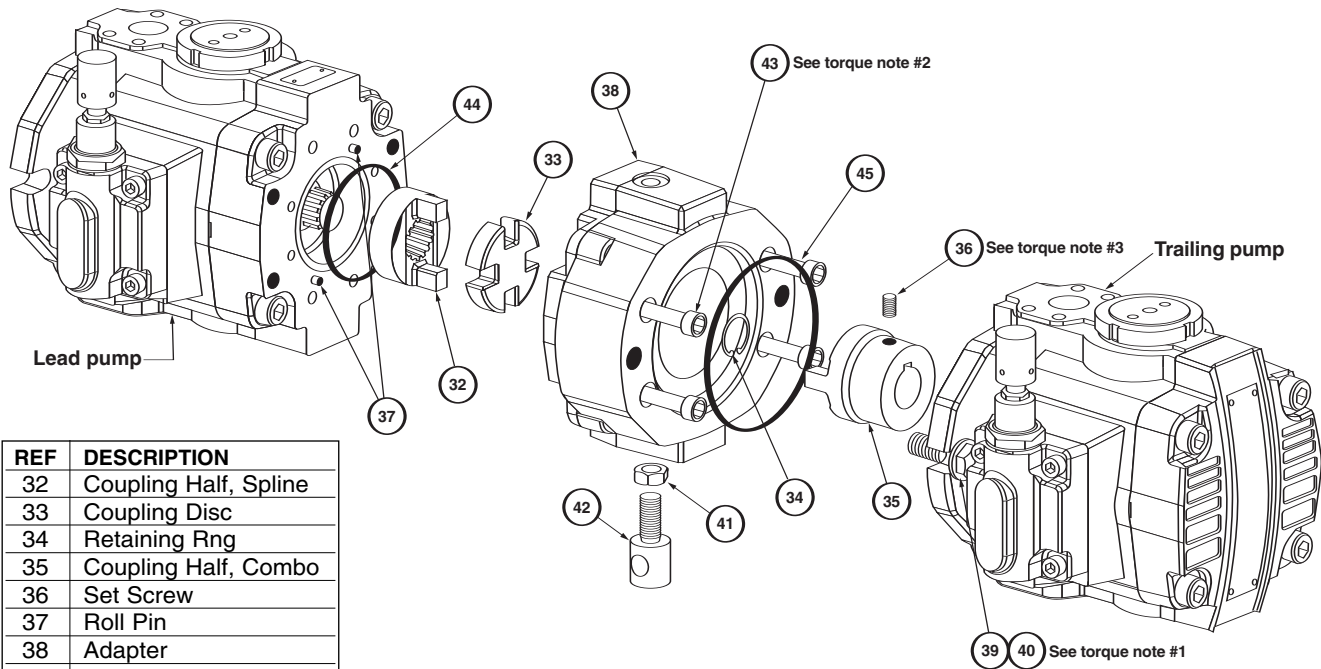

REF	DESCRIPTION
32	Coupling Half, Spline
33	Coupling Disc
34	Retaining Ring
35	Coupling Half, Combo
36	Set Screw
37	Roll Pin
38	Adapter
39	Washer
40	Hex Head Cap Screw
41	Jam Nut
42	Support
43	Soc. Head Cap Screw
44	O-Ring, ASA-043
45	O-Ring

Adapter KITS

PART NO.	DESCRIPTION
264240	PVX-8 to S.A.E "A"
264243	PVX-11/15 to S.A.E "A"
264244	PVX-11/15 to S.A.E "B"
264248	PVX-20/29/36 to S.A.E "A"
264249	PVX-20/29/36 to S.A.E "B"
264250	PVX-20/29/36 to S.A.E "C"
264257	PVX-46/60/75 to S.A.E "A"
264258	PVX-46/60/75 to S.A.E "B"
264259	PVX-46/60/75 to S.A.E "C"
264260	PVX-46/60/75 to S.A.E "D"

Torque Note #1	
Torque to 780 lb/in (Torque to 88 Nm)	PVX-8
Torque to 1050 lb/in (Torque to 119 Nm)	PVX-11/15
Torque to 1800 lb/in (Torque to 204 Nm)	PVX-20/29/36
Torque to 2000 lb/in (Torque to 225 Nm)	PVX-46/60/75
Torque Note #2	
Torque to 400 lb/in (Torque to 46 Nm)	PVX-8
Torque to 550 lb/in (Torque to 62 Nm)	PVX-11/15
Torque to 850 lb/in (Torque to 96 Nm)	PVX-20/29/36
Torque to 2300 lb/in (Torque to 260 Nm)	PVX-46/60/75
Torque Note #3	
Torque to 280 lb/in (Torque to 31.5 Nm)	PVX-11/15
Torque to 330 lb/in (Torque to 37 Nm)	PVX-20/29/36
Torque to 800 lb/in (Torque to 90 Nm)	PVX-46/60/75

PVX SERIES VANE PUMPS

DIMENSIONS FOR PUMP AND ADAPTER

FOR DOUBLE PUMP COMBINATION

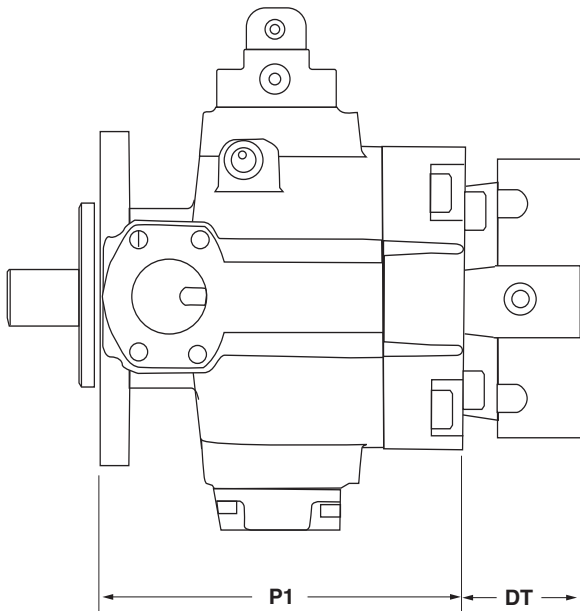

POSSIBLE SIZE COMBINATIONS	PUMP 1 (P1) Inches	Adapter (DT) Inches
PVX-8 to S.A.E. "A"	6.10	1.95
PVX-11/15 to S.A.E. "A"	6.94	1.95
PVX-11/15 to S.A.E. "B"	6.94	2.55
PVX-20/29/36 to S.A.E. "A"	9.64	2.60
PVX-20/29/36 to S.A.E. "B"	9.64	3.59
PVX-20/29/36 to S.A.E. "C"	9.64	3.80
PVX-45/60/75 to S.A.E. "A"	12.00	2.61
PVX-45/60/75 to S.A.E. "B"	12.00	3.19
PVX-45/60/75 to S.A.E. "C"	12.00	3.80
PVX-45/60/75 to S.A.E. "D"	12.00	4.83

THROUGH DRIVE HORSEPOWER

The PVX Series pumps can be coupled with other pumps with standard SAE mounting patterns (PVX pumps can be coupled without losing use of stroke limiter). PVX combination pumps are rated to carry the load of an additional pump(s) equal to the maximum load of the lead PVX pump it can generate (see chart).

PUMP	FLOW @ 1750 RPM (GPM)	MAXIMUM PRESSURE (PSIG)	PUMP #1 INPUT HORSEPOWER	MAXIMUM INPUT HORSEPOWER OTHER PUMPS
PVX-8	8.03	3000	17.6	17.6
PVX-11	12.6	3000	25.3	25.3
PVX-15	15.4	3000	30.7	30.7
PVX-20	21.8	3000	43.3	43.3
PVX-29	29.6	3000	58.5	58.5
PVX-36	37.2	3000	74.6	74.6
PVX-46	46.2	3000	88.8	88.8
PVX-60	60.0	3000	117.6	117.6
PVX-75	75.8	3000	156.5	156.5

EXAMPLES:

PVX-46 @ 3045 psig + PVX-29 @ 3045 psig + PVX-11 @ 3045 psig
 88.8 HP ≥ 58.5 + 23.3

PVX-8 @ 3045 psig + PVX-8 @ 1500 psig + PVX-8 @ 1500 psig
 17.6 HP ≥ 8.7 + 8.7

PVX SERIES VANE PUMPS

PVX PUMP CONTROLS

Schematics shown illustrate PVX20 - 75 pump controls with shock clipper integrated and no exterior plumbing required. The case drain shows an integrated check valve not present in PVX-8/11/15 pumps. All controls leave the factory preset at 500 psi (34 bar).

SINGLE STAGE COMPENSATOR — CODE 01

The single stage control for normal pressure compensation is a good choice where speed is important and remote capability is not required. This control is available on PVX-8/11/15.

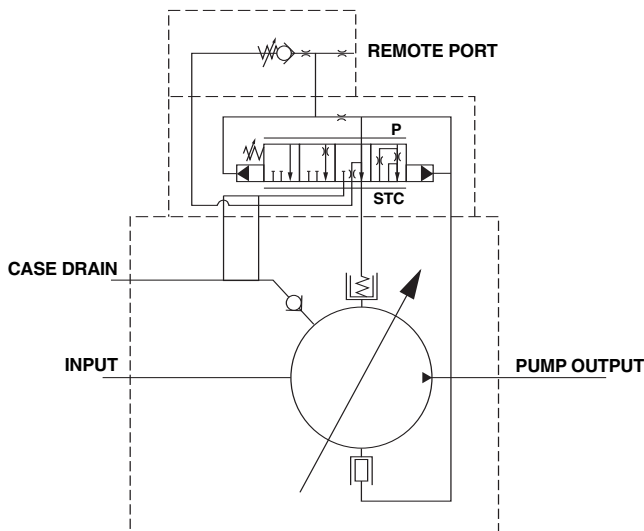
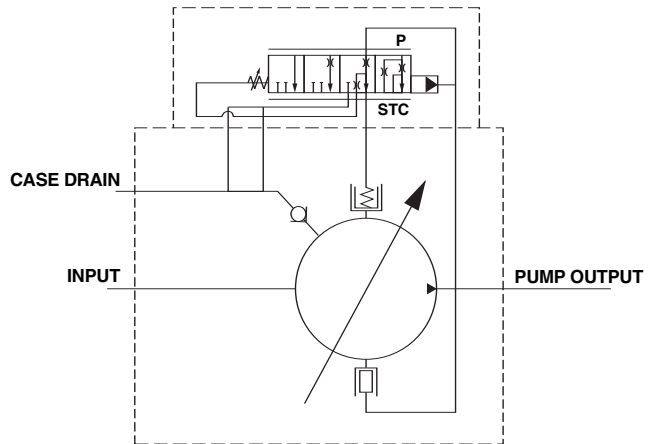

TWO STAGE COMPENSATOR — CODE 17

The two (2) stage pressure compensators are the platform for most PVX controls. A remote port is standard and may, or may not be enabled according to the circuit design. This is the smoothest of the standard pressure controls, and is the standard pressure compensator for PVX-20/29/36/46/60/75.

LOAD SENSE COMPENSATOR — CODE 19

Load sense allows the user to maintain constant flow regardless of changes in load or in pump shaft rotational speed. The load sense compensator accomplishes this by using an external orifice and continually senses a pressure drop of 100 psi (7 bar) across the orifice. The minimum ΔP is 100 psi (7 bar), however, the pressure drop can be adjusted to meet circuit requirements. Consult the factory.

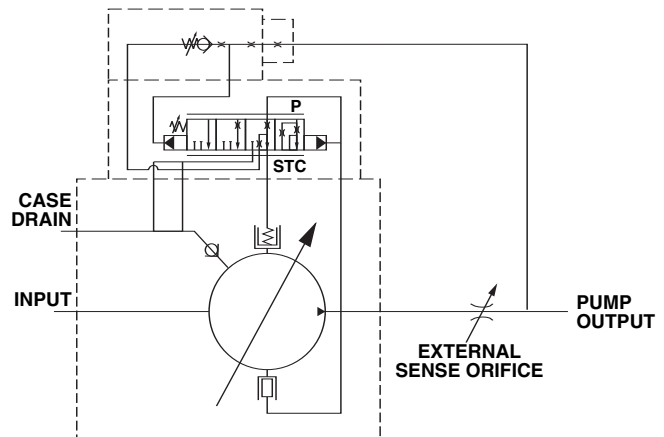

TWO PRESSURE COMPENSATOR — CODES 27 & 28

Solenoid two pressure compensators are available in normally open (CODE 27 — normally low, energize to high) and normally closed (CODE 28 — normally high, energize to low) versions. These two pressure controls can greatly reduce horsepower demand and heat generation during periods of idle cycle time, or when the machine operating cycle does not require maximum pressure.

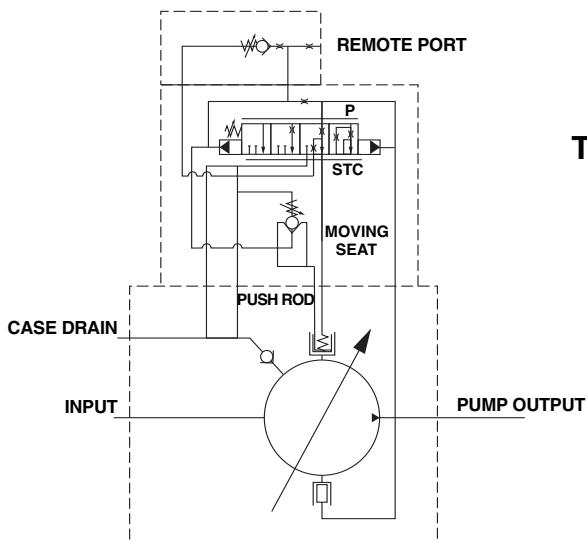
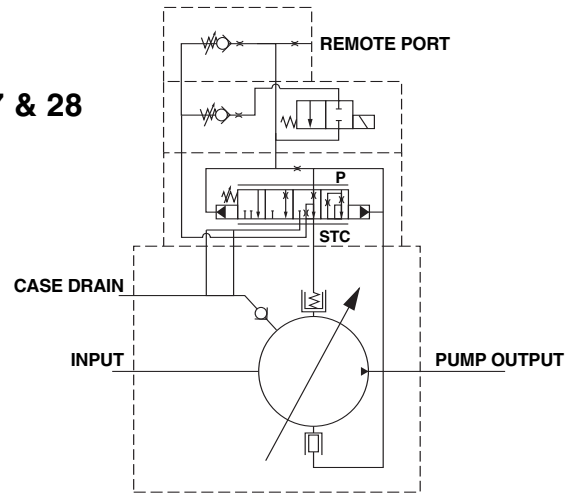

TORQUE LIMITING COMPENSATOR — CODE 26

Torque limiting for PVX limits the input torque to the pump shaft, in effect limiting the horsepower transmitted to the load. No torque or horsepower sensing is done on the load, only at the pump itself. Pump output flow rate is linear and proportional to movement of the pressure ring. This compensator is adjustable in the field as torque vs. flow requirements demand. Consult the factory for adjustment procedure.

SOLENOID VENT COMPENSATOR — CODE 29 & 30

Solenoid vented compensators are similar to the two-pressure controls, except that there is no adjustable minimum. By venting the compensator the pump will go to minimum deadhead.

CODE 29 — Normally vented to minimum, energize to high pressure

CODE 30 — Normally high pressure, energize to vented minimum

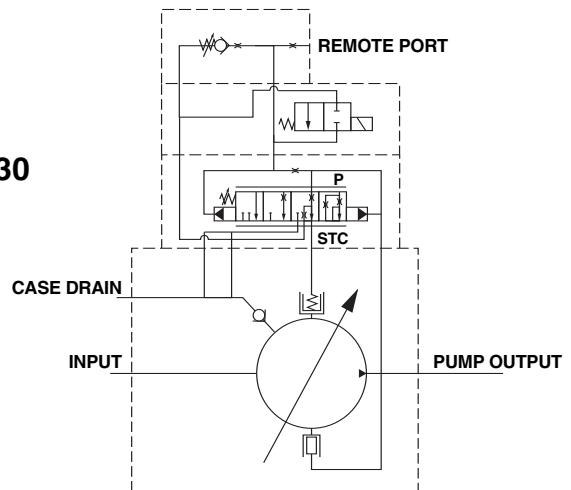

PVX SERIES VANE PUMPS

REACTION CHARACTERISTICS AND SHOCK CLIPPER FUNCTION

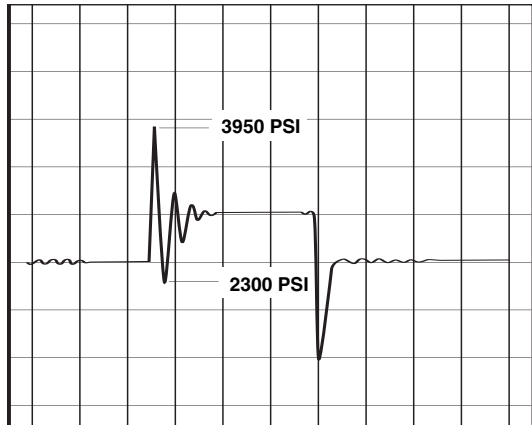
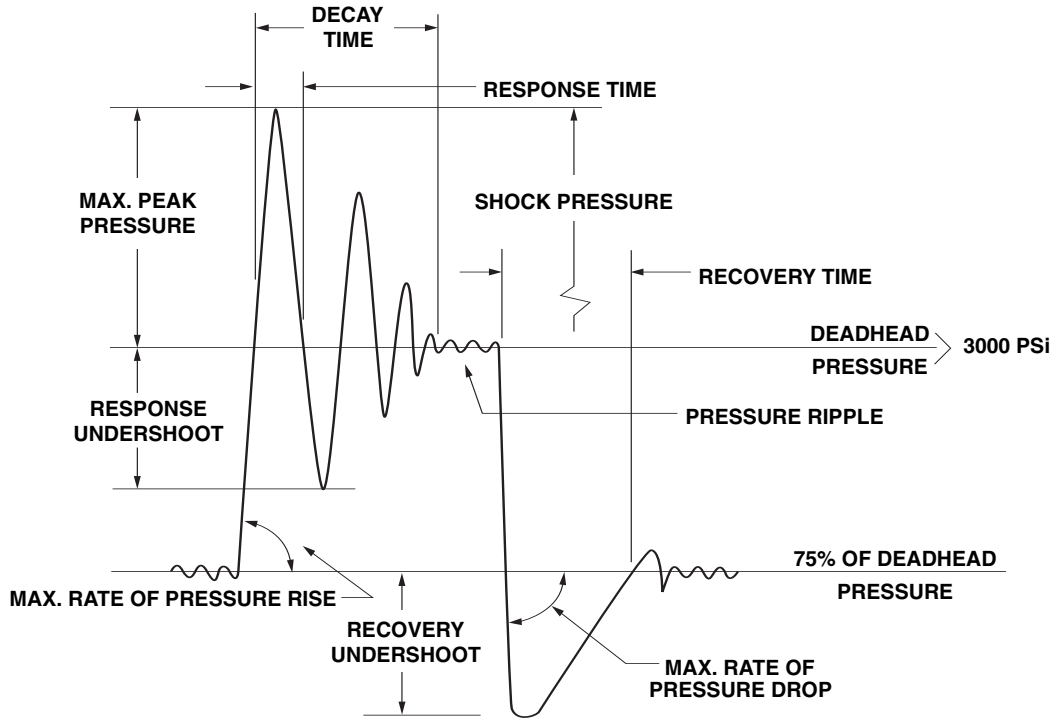

PVX-8 single stage compensator, plot with shock clipper inactive. Response overshoot of 950 psi (66 bar), response undershoot of 700 psi (48 bar)

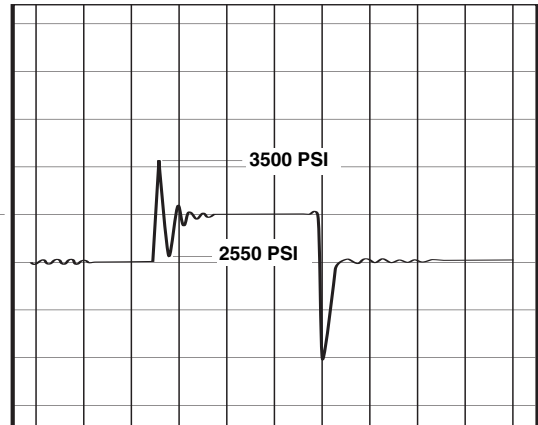

PVX-8 single stage compensator, plot with shock clipper active. Response overshoot of 500 psi (34 bar), response undershoot of 450 psi (31 bar)

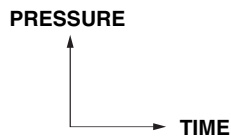

SINGLE STAGE COMPENSATOR

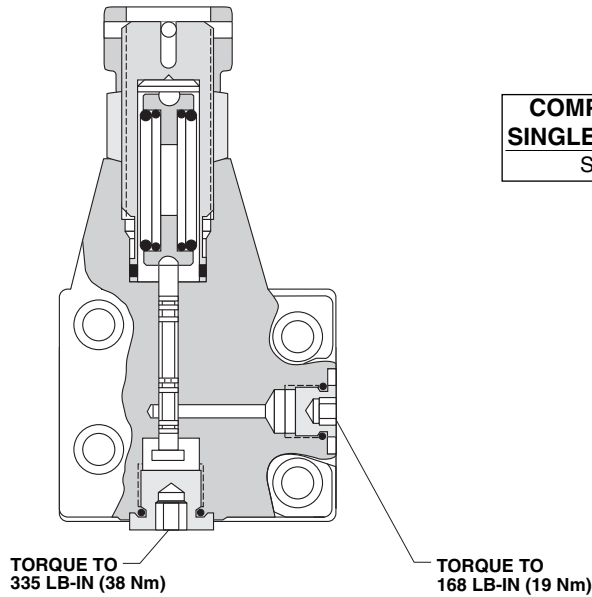

COMPLETE ASSEMBLY FOR SINGLE STAGE COMPENSATOR	
SAE	264404

ATTENTION: These compensators are rated for 3000 psi (210 bar) operation. Install only on pumps rated at 3000 psi (210 bar). Activating shock clipper is highly recommended on all applications greater than 2000 psi (140 bar). Install unrestricted line back to the tank.

TWO STAGE COMPENSATOR

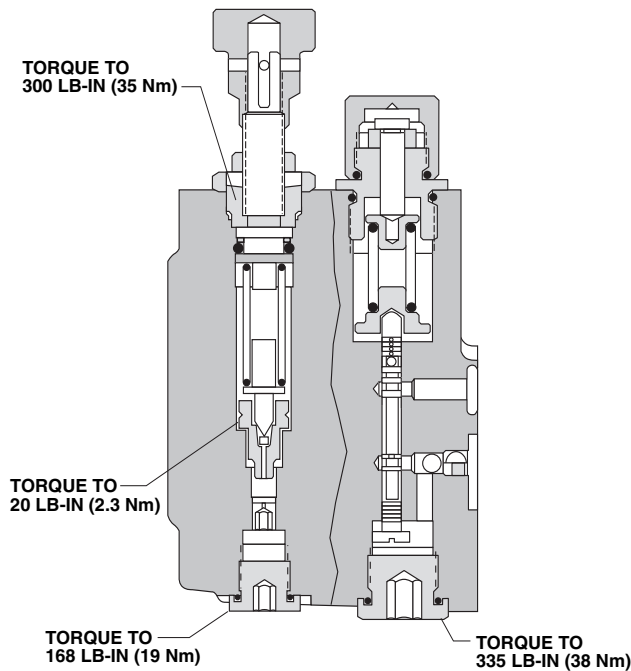

COMPLETE ASSEMBLY FOR TWO STAGE COMPENSATOR	
SAE	264405

COMPLETE ASSEMBLY FOR LOAD SENSE	
SAE	264406

PVX SERIES VANE PUMPS

REPAIR PARTS - PVX-20/29/36/46/60/75

TWO STAGE COMPENSATOR

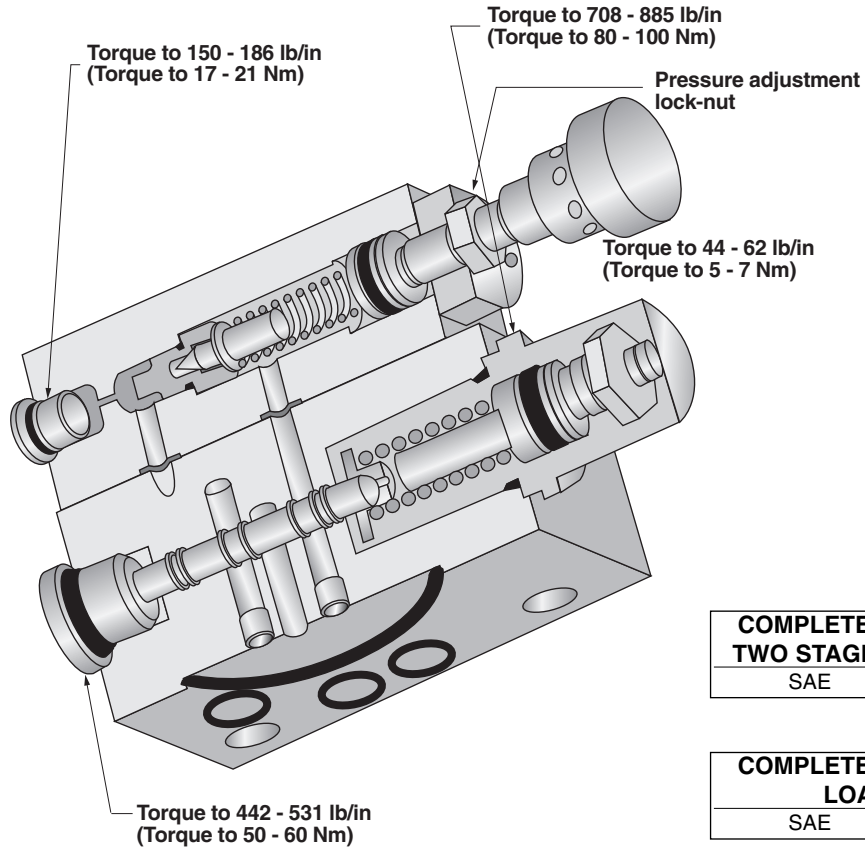

COMPLETE ASSEMBLY FOR TWO STAGE COMPENSATOR	
SAE	264407

COMPLETE ASSEMBLY FOR LOAD SENSE	
SAE	264408

ATTENTION: These compensators are rated for 3000 psi (210 bar) operation. Install only on pumps rated at 3000 psi (210 bar).

NOTE: Quantity of 3, M6 socket head cap screw, not shown.
Mounts 2nd stage to 1st stage compensator.
Torque to 133 - 177 lb/in (15 - 20 Nm)

PVX SERIES VANE PUMPS

VARIABLE DISPLACEMENT, PRESSURE COMPENSATED

STROKE LIMITER ADJUSTMENT

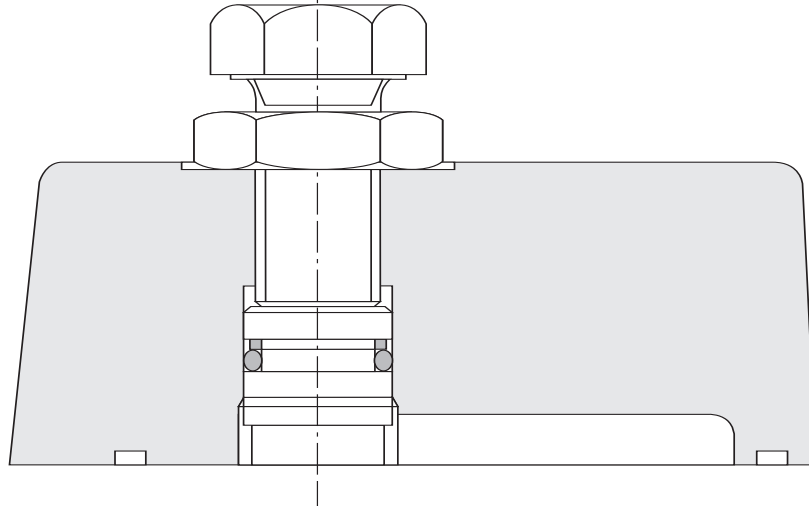

STROKE LIMITER ADJUSTMENT			
PUMP MODEL	NOMINAL STROKE	DECREASE IN FLOW PER TURN	MINIMUM FLOW ATTAINABLE
PVX-8	0.075" (1.9 mm)	53%	<0%
PVX-11	0.080" (2.0 mm)	50%	0%
PVX-15	0.099" (2.5 mm)	40%	20%
PVX-20	0.077" (1.9 mm)	80%	<0%
PVX-30	0.106" (2.7 mm)	56%	8%
PVX-36	0.132" (2.4 mm)	44%	26%
PVX-46	0.117" (3.0 mm)	50%	17%
PVX-60	0.150" (3.8 mm)	40%	34%
PVX-75	0.186" (4.7 mm)	32%	47%

During initial start-up, volume should be at least 50% of maximum flow.

Only make adjustments to the volume control with the pump running at full flow and low pressure while observing output flow.

PVX-8/11/15 VANE PUMPS

REPAIR PARTS KITS

REPAIR KITS

MODEL	SAE	SAE - "P1"
PVX-8	264288	264289
PVX-11/15	264292	264293

SEAL KITS

MODEL	SAE
PVX-8	264275
PVX-11/15	264276

VANE KITS

MODEL	SAE
PVX-8	264270
PVX-11/15	264271

Repair kits consists of:

REF	DESCRIPTION	QTY
1	Key	1
2	Roll Pin	4
3	Vane Kit	1
4	Spacer Ring	1
5	Pressure Ring	1
6	Port Plate, Body	1
7	Port Plate, Cover	1
8	Thrust Screw	1
9	Lock Nut	1
10	Shaft	1
11	Retaining Ring (PVX-8)	1
12	Bearing	2

Seal repair kits consists of:

REF	DESC. PVX-8 (PVX-11/15)	QTY
13	O-Ring ASA-111 (ASA-111)	1
14	O-Ring ASA-110 (ASA-110)	1
15	O-Ring ASA-127 (ASA-136)	2
16	O-Ring ASA-128 (ASA-128)	1
17	O-Ring ASA-026 (ASA-028)	2
18	O-Ring ASA-151 (ASA-152)	2
19	O-Ring ASA-031 (ASA-031)	1
20	O-Ring ASA-156 (ASA-160)	1
21	Back-Up Ring	2
22	Shaft Seal	1
23	O-Ring ASA-011	1
24	Back-Up Ring	1
25	Control Piston	1
26	Bias Piston	1

NOTE: All O-Rings have durometer rating of 75.

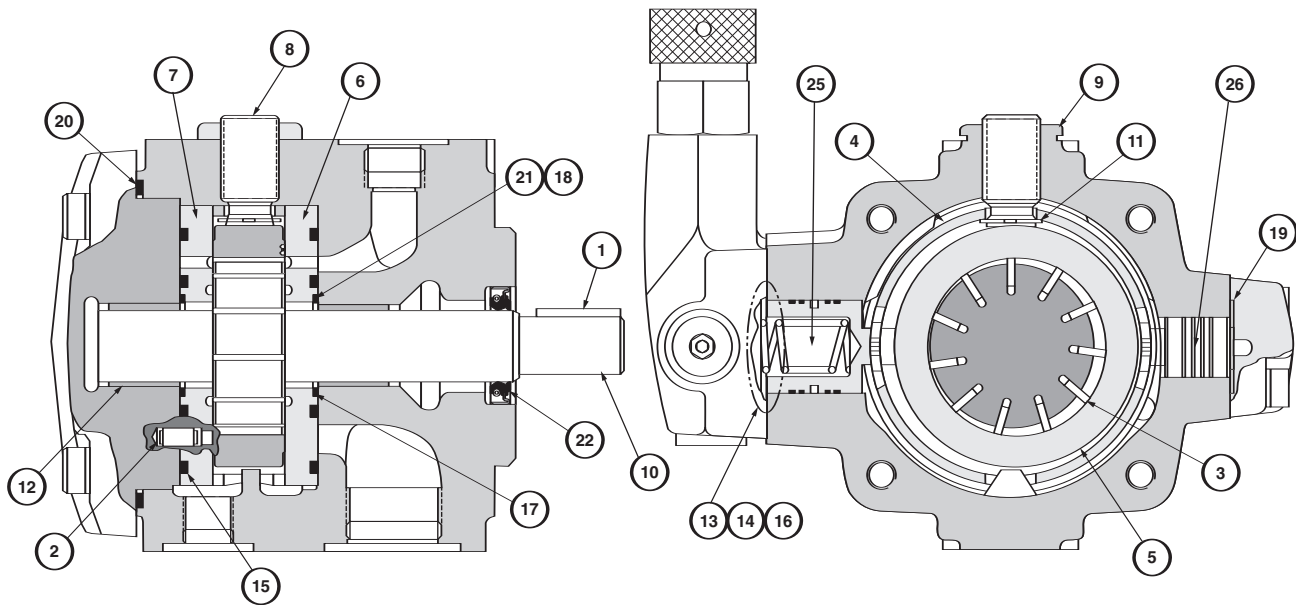

INSTALLATION NOTES

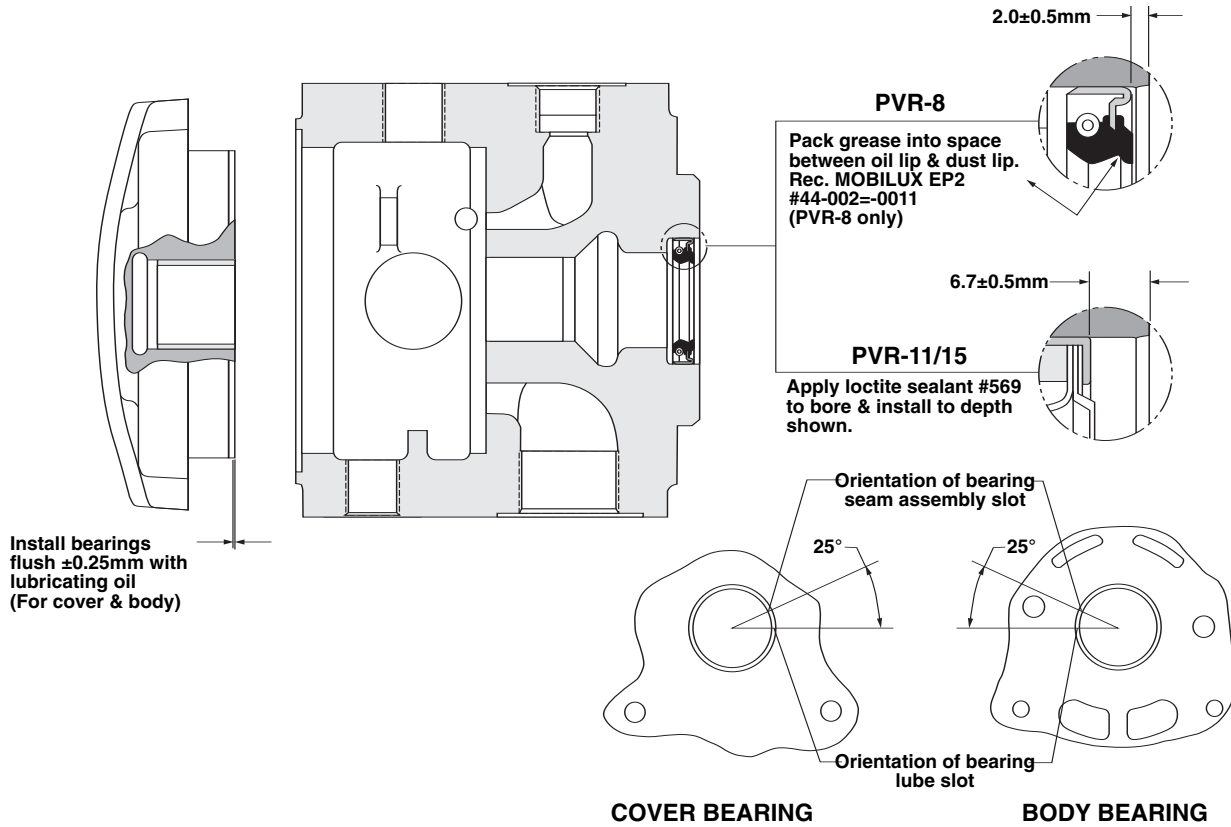

BOLT TORQUE RATINGS

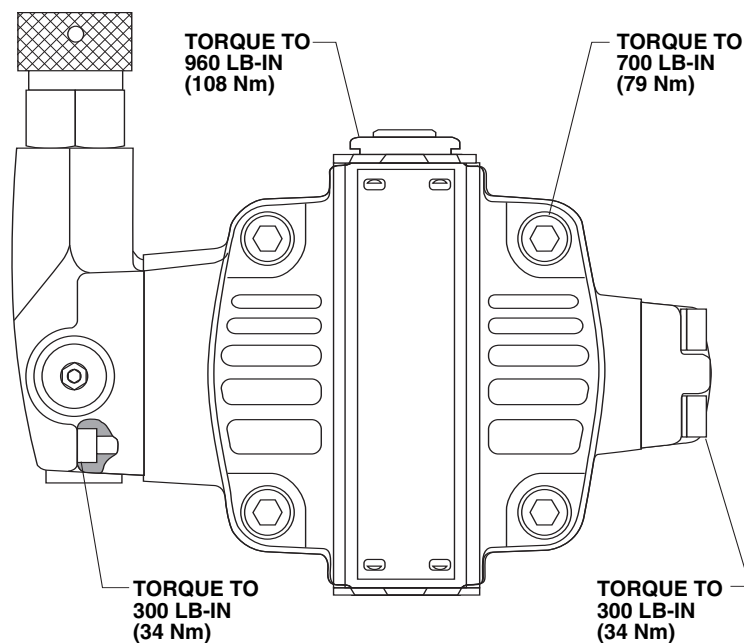

PVX-20/29/36/46/60/75 VANE PUMPS

REPAIR PARTS KITS

REPAIR KITS

MODEL	SAE	SAE - "P1"
PVX-20	264296	264297
PVX-29	264296	264297
PVX-36	264300	264301
PVX-46	264304	264305
PVX-60	264304	264305
PVX-75	264308	264309

Repair kits consists of:

REF	DESCRIPTION	QTY
1	Key	1
2	Rotor shaft	1
3	Vane Kit	1
4	Port Plate, Cover	1
5	Roll Pin	4
6	Thrust Block Kit	1
7	Bearing	2
8	Spacer Ring	1
9	Pressure Ring	1
10	Port Plate, Body	1

SEAL KITS

MODEL	SAE
PVX-20/29/36	264277
PVX-46/60/75	264278

Seal repair kits consists of:

REF	DESC. PVX-20/36 (PVX-46/60/75)	QTY
13	O-Ring ASA-031 (ASA-035)	2
14	O-Ring ASA-162 (ASA-265)	1
15	O-Ring ASA-130 (ASA-229)	1
16	O-Ring ASA-146 (ASA-146)	1
17	Shaft Seal	1
18	O-Ring ASA-229 (ASA-237)	1
19	O-Ring ASA-110 (ASA-110)	1
20	O-Ring ASA-111 (ASA-111)	3
21	O-Ring ASA-143 (ASA-143)	1
22	O-Ring ASA-157 (ASA-160)	2
23	Back-Up Ring	2
24	O-Ring ASA-139 (ASA-152)	1
25	O-Ring ASA-043 (ASA-043)	2

NOTE: All O-Rings have durometer rating of 75.

VANE KITS

MODEL	SAE
PVX-20/29/36	264272
PVX-46/60	264273
PVX-75	264274

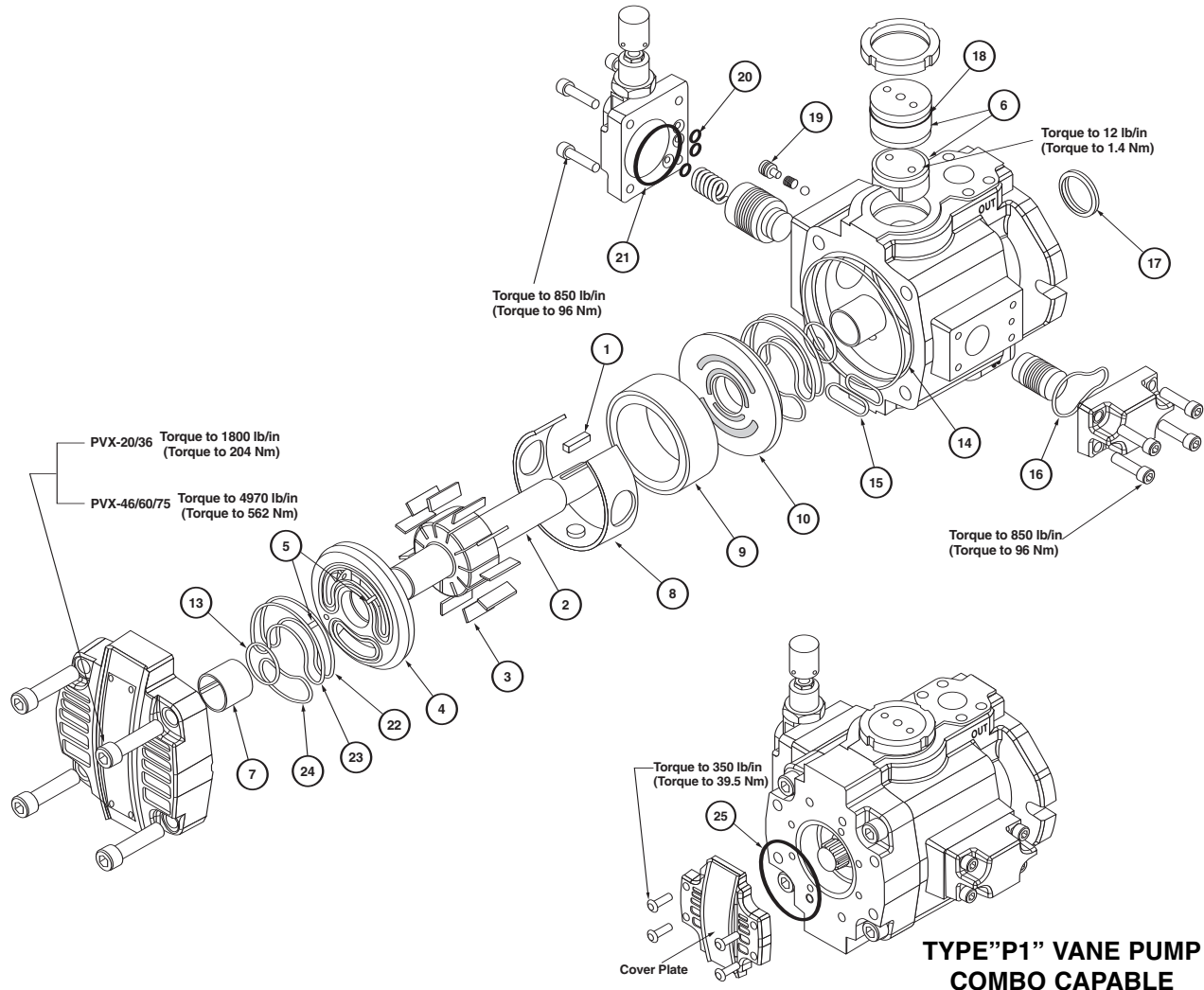

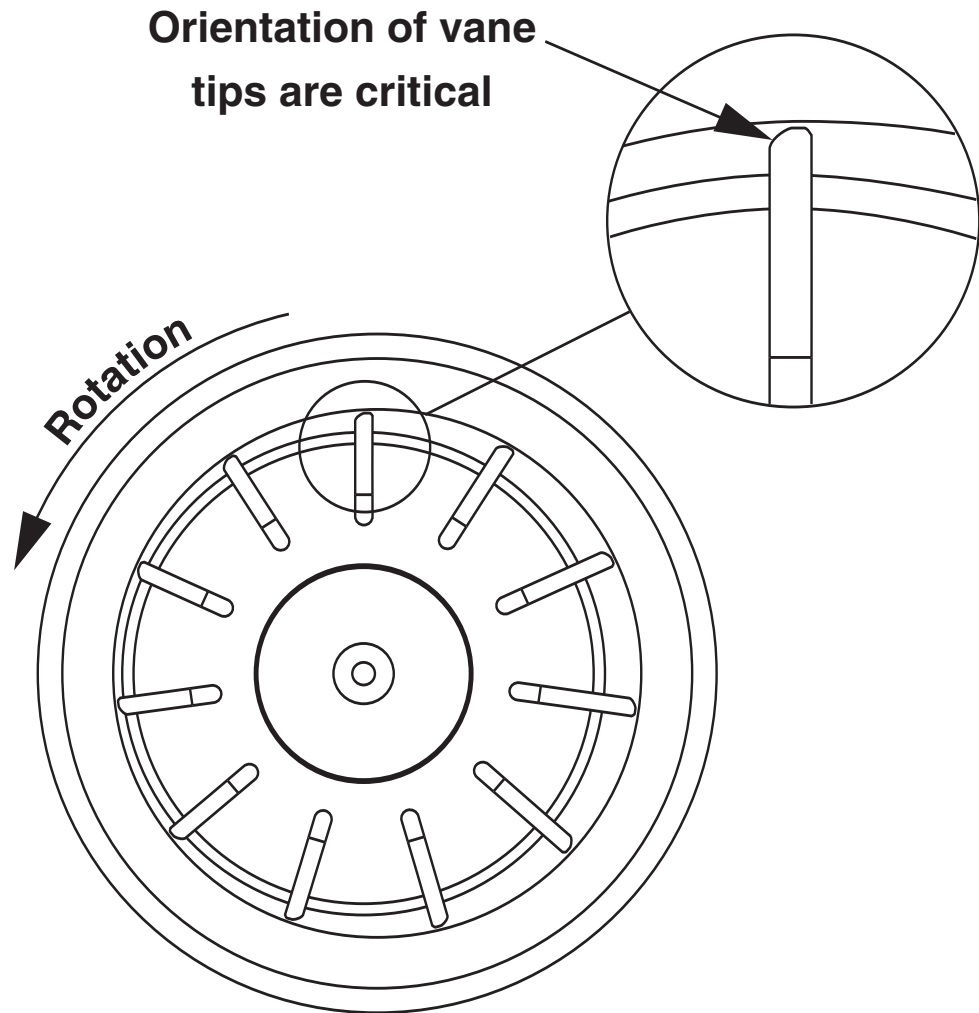

**Looking into pump body
from cover side**

PVX SERIES VANE PUMPS

TROUBLE SHOOTING

Some of the most common difficulties that could be experienced in the field are listed here with potential causes and their remedies.

TROUBLE	POTENTIAL CAUSE	REMEDY
Excessive pump noise	1) Coupling misalignment	1) Align the pump and motor shaft to within .006 (.152 mm) of an inch total indicator reading. The tighter the alignment, the quieter the pump will be.
	2) The continuous pressure is significantly below 300 psi for 210 bar pumps.	2) The pumps have been sound tuned at rated pressure. Consult factory or raise minimum pressure 200 psi for single stage compensators in 2000 psi rated pumps, or 300 psi for 3000 psi rated pumps.
	3) Fluid in the reservoir is low and the pump is sucking air.	3) Fill the reservoir so that the fluid level is well above the end of the suction line during all of the working cycle.
	4) Restricted inlet.	4) If a suction strainer is used, check it for obstructions or dirt. It is not recommend the use of strainers as they tend to be a leading cause of cavitation which manifests as excessive noise. Check also for shop rags left in the reservoir.
	5) Air leak in the suction line.	5) Tighten all fittings. If it still leaks, smear grease over the joints to locate the leak.
	6) Suction line has too many elbows, or is too long.	6) The suction line should be as short and as straight as possible reduce the resistance to flow.
	7) Air in the fluid.	7) The return line should terminate below the fluid level to prevent splashing.
	8) Suction line is too small.	8) Suction line should always be equal in size to the suction port. Never reduce it.
	9) Vane does not move freely.	9) Contamination in the fluid or a burr in the vane slot can cause a vane to bind up. Proper filtration and/or deburring of the vane slots is required.
	10) Vane is installed incorrectly.	10) Vanes must be mounted with the rounded edge toward the ring.
	11) A vane is missing.	11) Make sure all vane slots have a vane in them.
	12) Port plates installed incorrectly.	12) Plates must be installed so that the arrows point in the same direction as the rotational arrows on the pump body.
Pump will not prime	1) Shaft rotation in the wrong direction.	1) When installing a pump, always jog the electric motor to check for proper shaft rotation. Rotation should only be clockwise (right hand) for PVX pumps.
	2) Air leak in the suction line.	2) Make sure all fittings are tight.
	3) Pump is air bound.	3) Use an air bleed valve to void the pump and suction line of air.
	4) Fluid level in the reservoir is too low.	4) Fill the reservoir so that the fluid level is well above the end of the suction line.
	5) Stroke limiter is turned in too far.	5) Flow should not be reduced more than 50% of maximum. Turn CW to restrict flow (see chart, page 41).
	6) Suction port dust plug left in place.	6) Remove plug.
Pump is unstable	1) Contamination in the compensator.	1) Thoroughly clean the control orifices and check filtration.
	2) Pressure ring is not moving properly.	2) Control piston should be checked for freedom of movement.
Pump is too hot	1) Case drain line is installed too close to the pump inlet line.	1) The case drain and pump inlet should be separated by a baffle in the reservoir.
	2) Reservoir is undersized. Rule of thumb is a minimum of 2 to 3 times pump output flow.	2) Add a cooler.

POWRFLOW™ PVX VANE PUMPS

PVX VANE PUMPS ARE DESIGNED TO BE QUIET.

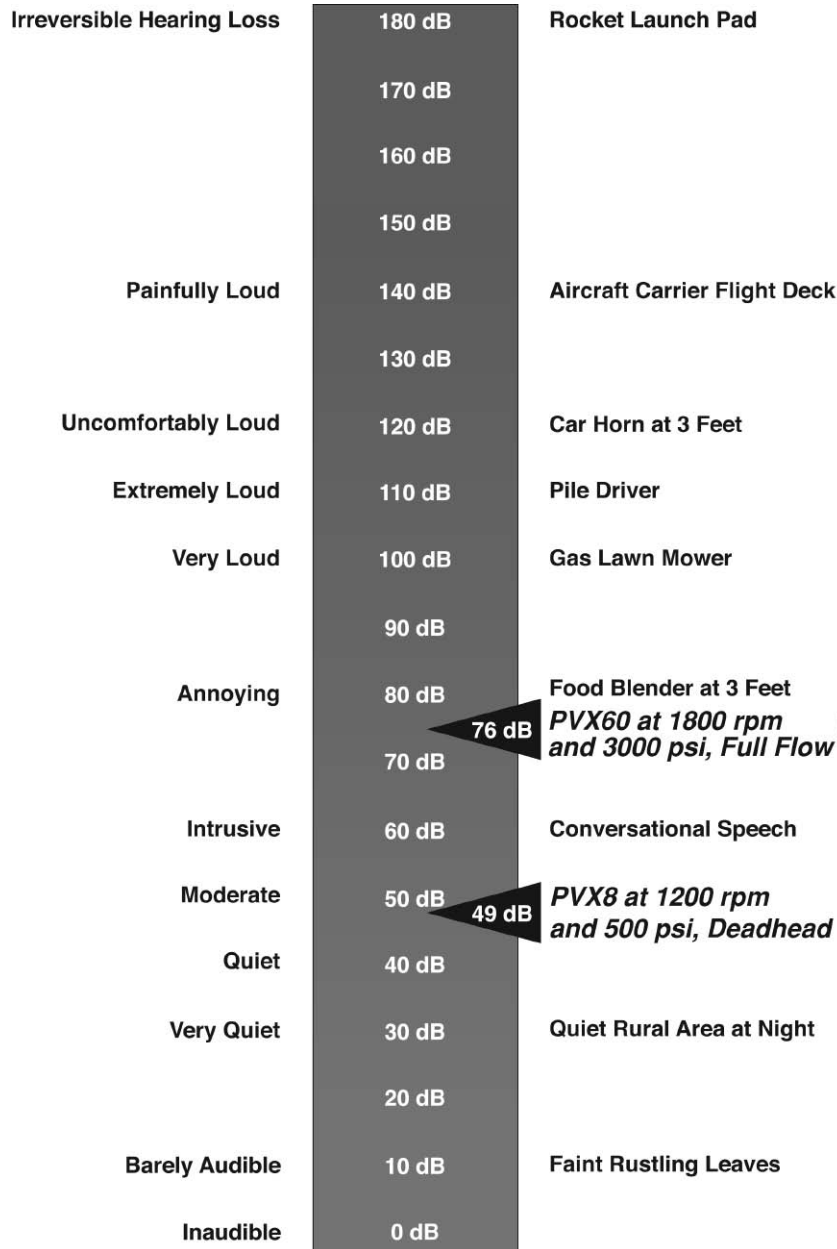

PowrFlow™ PVX Vane Pumps Are Quiet.

PVX Vane Pumps are designed to be quiet. Using them in your machinery designs makes it easier to meet government mandated or purchaser required sound levels.

And, vane pumps are inherently smooth operating. Piston pumps exert push-pull forces, which can lead to hydraulic line pulsation and hammering. PVX Vane Pumps maintain constant system pressure to eliminate pulsations and associated noise.

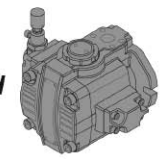
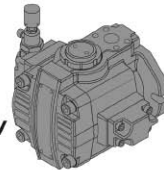

Exclusive 3 Year Warranty

Continental Hydraulics Division warrants all vane pumps supplied by Continental Hydraulics against defects in material and workmanship under normal use and service for three years from the date of shipment.

This warranty does not cover ordinary wear and tear, abuse, misuse, overloading, altered products, use of improper fluid, or use of materials not of Continental Hydraulics manufacture or supply.

PVX SERIES VANE PUMPS

OPTIMUM OPERATING VISCOSITIES

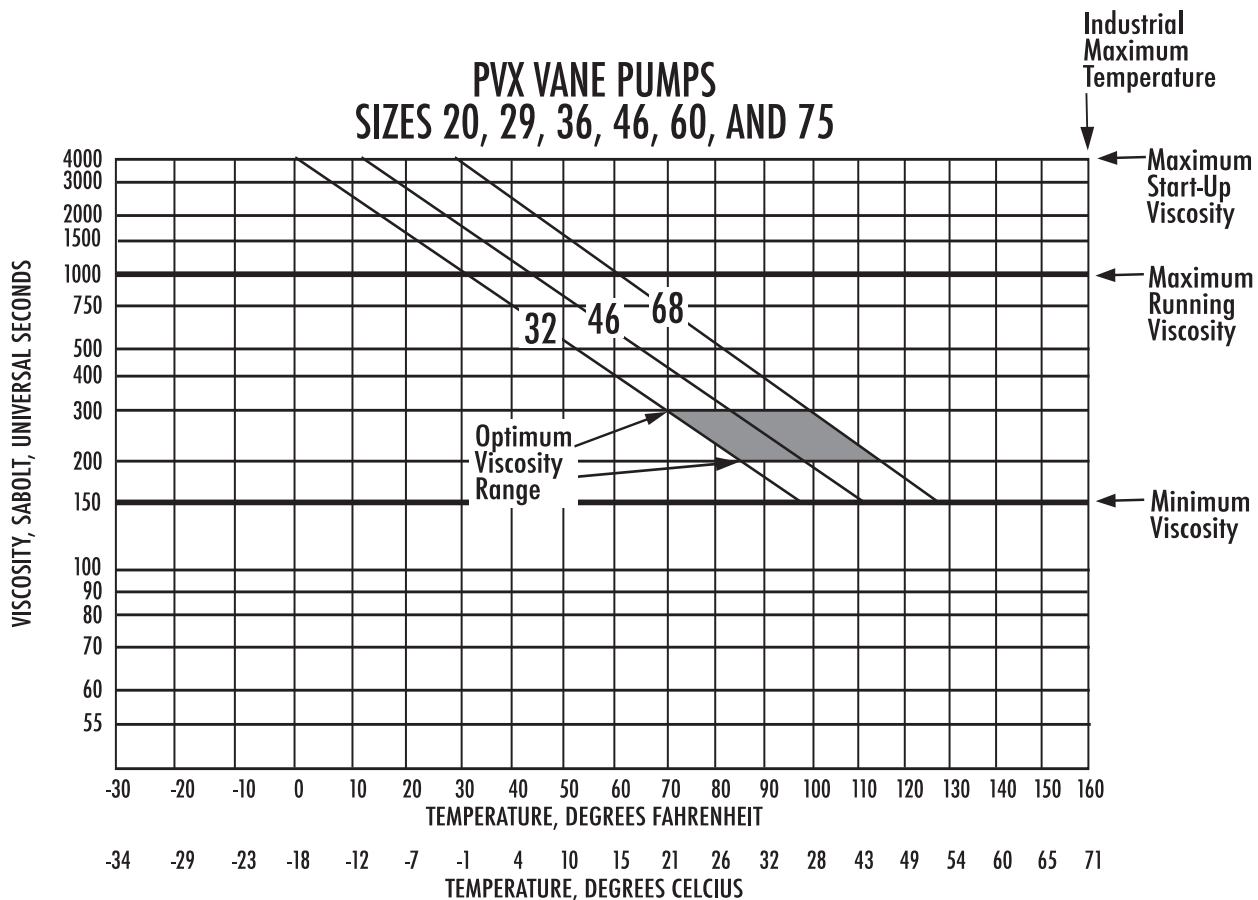
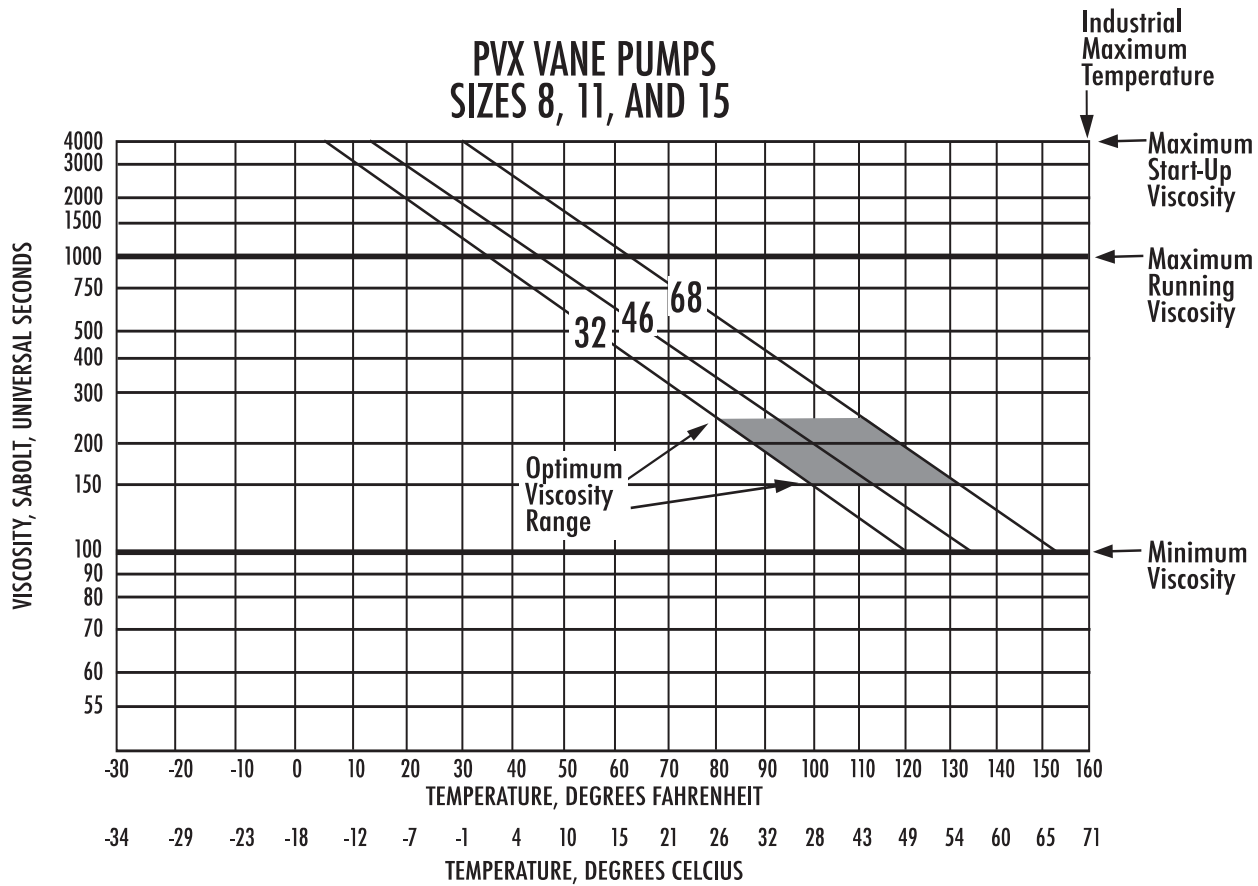

POWRFLOW™ PVX VANE PUMPS



YOUR SOURCE FOR VANE PUMPS FOR THE MOST DEMANDING APPLICATIONS



Why settle for “close enough” when you need hydraulics?

Continental Hydraulics offers a complete line of products to meet your need for reliable, precise fluid power. In addition to the PVX Vane Pumps shown in this catalog, Continental also offers vane and piston pumps, a full line of control valves, integrated hydraulic circuits, and hydraulic power units.

Continental's products are used in diverse applications such as plastic molding machinery, machine tools, pulp and paper machines, marine auxiliary power controls and deck handling equipment, and masonry product production equipment.

Distributors who know how to help — Anyone can say, “Here’s our catalog, take your pick.” Continental Distributors work with you to find out what you need, and with our engineers to make sure you get it.

Service and support — To provide maximum service and assistance, Continental Hydraulics maintains a strong distribution network, with representatives throughout North America and around the world. The average Continental Distributor has been with us for 15 years. He’s got repair and

replacement parts, and the skill to solve your hydraulics problem.

Our Distributors work hand-in-hand with our Engineers to select components and build systems that will meet your toughest specifications. And they’ll suggest creative solutions that can help save money or enhance performance.

Whether you need a complete hydraulic power supply or a single directional control valve, come to Continental.

CONTINENTAL



HYDRAULICS™

5505 West 123rd Street • Savage, MN 55378-1299 • Ph: 952.895.6400 • Fax: 952.895.6444 • www.continentalhydraulics.com

Form No. 264531 Rev. 7/06 © 2006 Continental Hydraulics. All rights reserved. Product specifications and appearance are subject to change without notice.