

Variable Displacement Single Vane Pump

Most standard variable-displacement vane pumps. Widely used for machine tools etc. because of their stable performance.

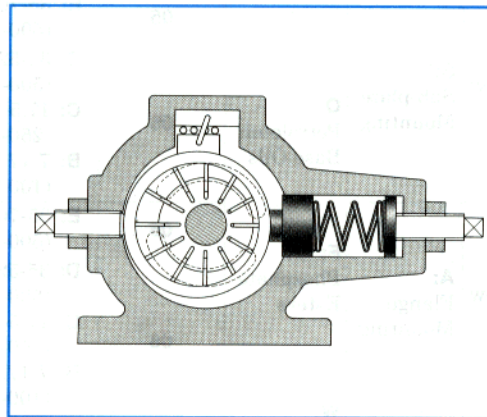

Graphic Symbol

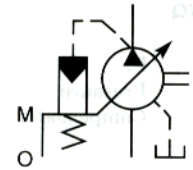

Ratings

Model Numbers	Max. Operating Pressure bar (PSI)	Output Flow at 3.5 bar (50 PSI)		Shaft Speed Range rpm (r/min)		Mass kg (lbs.)	Remarks
		at 1200 rpm (r/min)	at 1800 rpm (r/min)	Max.	Max.		
VPVQ-PSS*-05ER-60*	70 (1000)	13.3 (3.5)	20 (5.3)	1800	400	7.8 (17.2)	Sub-plate Mtg. With Volume Cont.
VPVQ-PSS*-06DR-60*	52 (750)	17.3 (4.6)	26 (6.9)				
VPVQ-PSS*-06CR-60*	35 (500)	17.3 (4.6)	26 (6.9)				
VPVQ-PSS*-06BR-60*	17.5 (250)	17.3 (4.6)	26 (6.9)				
VPVQ-PSA*-05ER-60	70 (1000)	13.3 (3.5)	20 (5.3)	1800	400	8.0 (17.6)	Flange Mtg. With Volume Cont.
VPVQ-PSA*-06DR-60	52 (750)	18.6 (4.9)	28 (7.4)				
VPVQ-PSA*-06CR-60	35 (500)	18.6 (4.9)	28 (7.4)				
VPVQ-PSA*-06BR-60	17.5 (250)	18.6 (4.9)	28 (7.4)				
VPVS-PNS*-10ER-51*	70 (1000)	26.6 (7.0)	40 (10.6)	1800	400	20 (44.1)	Sub-plate Mtg. Non Volume Cont.
VPVS-PNS*-12CR-51*	35 (500)	32.6 (8.6)	49 (12.9)				
VPVS-PNS*-12BR-51*	17.5 (250)	32.6 (8.6)	49 (12.9)				

Yuken can offer large volume pump described below.

Consult Yuken for the details

Model Numbers	Max. Operating Pressure bar (PSI)	Output Flow at 1200 rpm {r/min} at No-Load with 32 cSt (150 SSU) Fluids	Shaft Speed Range rpm {r/min}
VPVF-*NT*-**R-50	70 (1000)	56-120 (14.8-31.7)	400-1500
VPVR-*SS*-**R-50	70 (1000)	118-163 (31.2-43.1)	400-1200

■ Model Number Designation

VPVQ	-P	S	S	O	-05	E	R	-60	*
Series Number	Type of Compensator	Volume Control	Mounting	Applicable Hydraulic Fluids	Delivery Designation	Pres. Compensating Range bar (PSI)	Direction of Rotation	Design Number	Design Std.
VPVQ	P: Pressure Compensator	S: With Screw Volume Control	S: Sub-plate Mounting	O: Petroleum Base Oils	05	E: 35-70 (500-1000) D: 35-52 (500-750)	(Viewed from Shaft End)	60	None: Japanese Std. "JIS" & European Design Std. 90: N. American Design Std.
					06	C: 17.5-35 (250-500) B: 7-17.5 (100-250)			
		S: With Screw Volume Control	A: Flange Mounting	F: Phosphate Esters	05	E: 35-70 (500-1000) D: 35-52 (500-750)	R: Clockwise	60	None: Japanese Std. "JIS"
					06	C: 17.5-35 (250-500) B: 7-17.5 (100-250)			
VPVS		N: No Volume Control	S: Sub-plate Mounting	W: Water Glycols	10	E: 35-70 (500-1000) C: 17.5-35 (250-500)		51	None: Japanese Std. "JIS" & European Design Std. 90: N. American Design Std.
					12	B: 7-17.5 (100-250)			

■ Sub-plates

Pump Model Numbers	Japanese Std. "JIS"		European Design Std.		N. American Design Std.	
	Sub-plate Model Numbers	Mass kg (lbs.)	Sub-plate Model Numbers	Mass kg (lbs.)	Sub-plate Model Numbers	Mass kg (lbs.)
VPVQ-PSS#	VPV20GM-LE-50	2.5 (5.5)	VPV20GM-LE-5080	2.2 (4.9)	VPV20GM-L-5090	4.0 (8.8)
	VPV20GM-ME-50	3.0 (6.6)	VPV20GM-ME-5080	2.9 (6.4)	—	—
	VPV20GM-HE-50	3.5 (7.7)	VPV20GM-HE-5080	3.6 (7.9)	VPV20GM-H-5090	5.5 (12.1)
VPVS-PNS#	VPV40GM-HE-50	7.0 (15.4)	VPV40GM-HE-5080	7.4 (16.3)	VPV40GM-L-5090	7.5 (16.5)
					VPV40GM-HE-5090	7.5 (16.5)
					VPV40GM-H-5090	10.0 (22.0)

- Sub-plates are available. Specify sub-plate model from the table above. When sub-plates are not used, the mounting surface should have a good machined finish.

■ Mounting Bolts

Only the subplate mounting type pumps are accompanied with the following mounting bolts.

Pump Model Numbers	Socket Head Cap Screw (4 Pcs.)	
	Japanese Std. "JIS" & European Design Std.	N. American Design Std.
VPVQ-PSS#	M10 x 25 Lg.	3/8-16UNC x 1 Lg.
VPVS-PNS#	M12 x 30 Lg.	7/16-14UNC x 1-3/16Lg.

Operating Characteristics

Typical delivery and input performance at 1800 rpm (r/min) with 32 cSt (150 SSU) fluid are shown in graph. For any other pressure and delivery setting, performance curve will be nearly in parallel with shown. The input can be calculated with the following formula;

$$\text{Input (kW)} = \frac{PQ}{600} + E_f$$

Where P = Pressure (bar)
 Q = Output Flow (l/min)
 E_f = Dead Head Power (kW)

$$\text{Input (HP)} = \frac{PQ}{1714} + E_f$$

Where P = Pressure (PSI)
 Q = Output Flow (U.S.GPM)
 E_f = Dead Head Power (HP)

VPVQ-PSS*-06BR

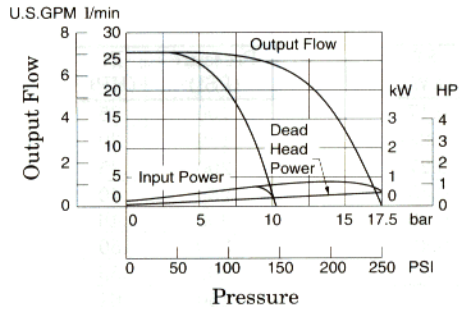

Pressure (bar)	E _f (kW)
5	0.20
10	0.26
15	0.36
17.5	0.45

Pressure (PSI)	E _f (HP)
50	.25
100	.29
150	.34
200	.40
250	.50

VPVQ-PSS*-06CR

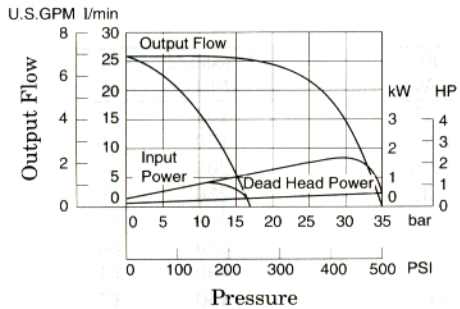

Pressure (bar)	E _f (kW)
5	0.22
10	0.24
15	0.27
20	0.32
25	0.39
30	0.48
35	0.55

Pressure (PSI)	E _f (HP)
100	.30
150	.32
200	.35
250	.39
300	.44
350	.50
400	.57
450	.65
500	.74

VPVQ-PSS*-06DR

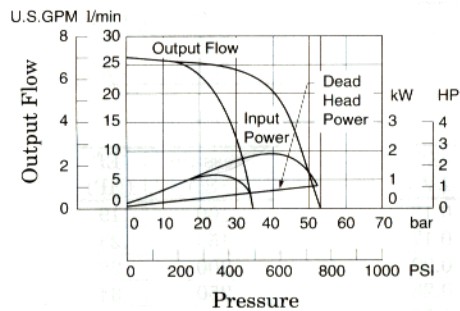

Pressure (bar)	E _f (kW)
5	0.22
10	0.23
15	0.26
20	0.31
25	0.36
30	0.43
35	0.48

Pressure (bar)	E _f (kW)
40	0.56
45	0.63
50	0.71
52	0.76

Pressure (PSI)	E _f (HP)
100	.29
150	.30
200	.33
250	.37
300	.42
350	.47
400	.52
450	.58
500	.64
550	.70

Pressure (PSI)	E _f (HP)
600	.77
650	.84
700	.92
750	1.00

VPVQ-PSS*-05ER

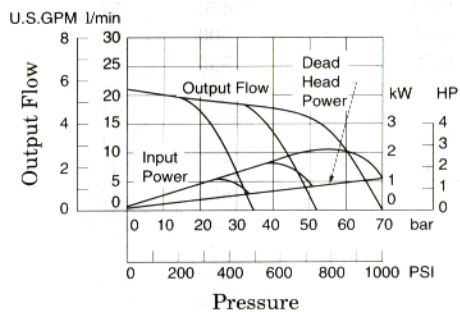

Pressure (bar)	E _f (kW)
5	0.22
10	0.23
15	0.26
20	0.31
25	0.36
30	0.43
35	0.48

Pressure (bar)	E _f (kW)
40	0.56
45	0.63
50	0.71
55	0.81
60	0.92
65	1.00
70	1.11

Pressure (PSI)	E _f (HP)
100	.29
150	.30
200	.33
250	.37
300	.42
350	.47
400	.52
450	.58
500	.64
550	.70

Pressure (PSI)	E _f (HP)
600	.77
650	.84
700	.92
750	1.00
800	1.09
850	1.18
900	1.28
950	1.38
1000	1.48

● **VPVQ-PSA*-06BR**

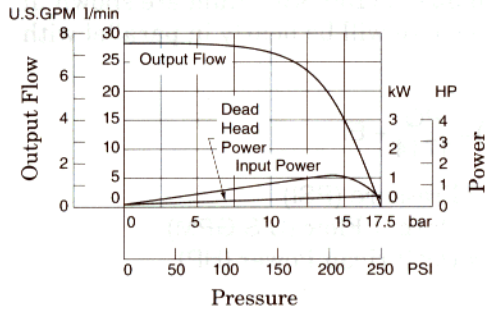

Pressure (bar)	Ef (kW)
5	0.17
10	0.22
15	0.27
17.5	0.31

Pressure (PSI)	Ef (HP)
50	.21
100	.25
150	.30
200	.35
250	.42

● **VPVQ-PSA*-06CR**

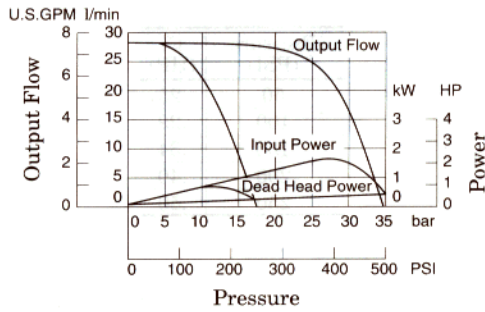

Pressure (bar)	Ef (kW)
5	0.17
10	0.22
15	0.27
20	0.33
25	0.38
30	0.43
35	0.50

Pressure (PSI)	Ef (HP)
100	.25
150	.30
200	.35
250	.40
300	.46
350	.50
400	.55
450	.61
500	.67

● **VPVQ-PSA*-06DR**

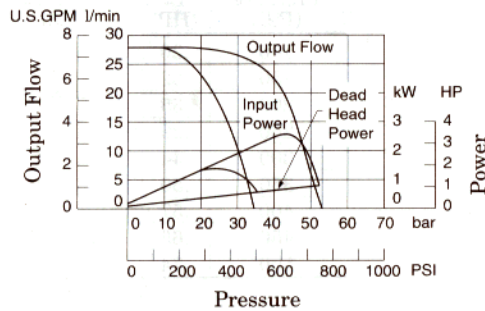

Pressure (bar)	Ef (kW)
5	0.15
10	0.22
15	0.26
20	0.32
25	0.41
30	0.48
35	0.55
40	0.67
45	0.76
50	0.88
52	0.92

Pressure (PSI)	Ef (HP)
100	.24
150	.30
200	.34
250	.39
300	.46
350	.54
400	.61
450	.67
500	.74
550	.85
600	.95
650	1.04
700	1.15
750	1.25

● **VPVQ-PSA*-05ER**

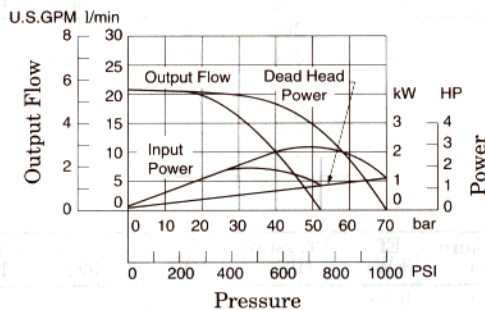

Pressure (bar)	Ef (kW)
5	0.13
10	0.17
15	0.22
20	0.28
25	0.32
30	0.41
35	0.46
40	0.54
45	0.61
50	0.70
55	0.79
60	0.89
65	0.98
70	1.16

Pressure (PSI)	Ef (HP)
100	.19
150	.23
200	.28
250	.34
300	.39
350	.43
400	.50
450	.57
500	.62
550	.69
600	.80
650	.83
700	.91
750	1.00
800	1.09
850	1.18
900	1.27
950	1.39
1000	1.56

● **VPVS-PNS*-12BR**

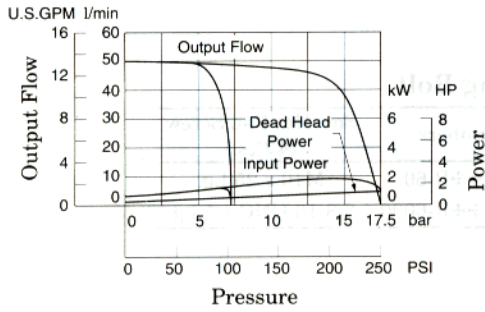

Pressure (bar)	Ef (kW)
5	0.38
10	0.40
15	0.53
17.5	0.70

Pressure (PSI)	Ef (HP)
50	.45
100	.50
150	.55
200	.65
250	.80

● **VPVS-PNS*-12DR**

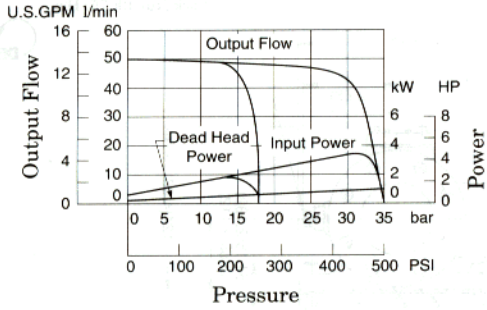

Pressure (bar)	Ef (kW)
5	0.38
10	0.40
15	0.47
20	0.53
25	0.58
30	0.72
35	1.10

Pressure (PSI)	Ef (HP)
100	.50
150	.55
200	.60
250	.65
300	.70
350	.75
400	.80
450	1.00
500	1.20

● **VPVS-PNS*-10ER**

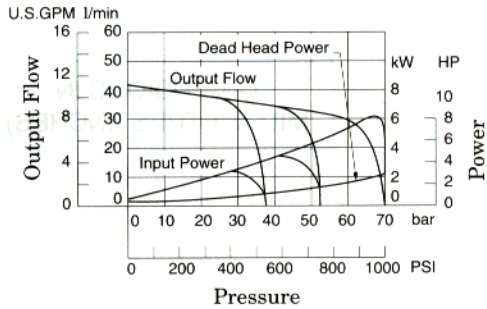

Pressure (bar)	Ef (kW)
5	0.38
10	0.40
15	0.47
20	0.59
25	0.70
30	0.81
35	0.94
40	1.13
45	1.24
50	1.42
55	1.56
60	1.72
65	1.90
70	2.23

Pressure (PSI)	Ef (HP)
100	.50
150	.55
200	.60
250	.70
300	.80
350	.90
400	1.00
450	1.12
500	1.25
550	1.39
600	1.53
650	1.67
700	1.81
750	1.95
800	2.09
850	2.23
900	2.37
950	2.55
1000	2.70

VPVQ-PSS*-***R-60/6090

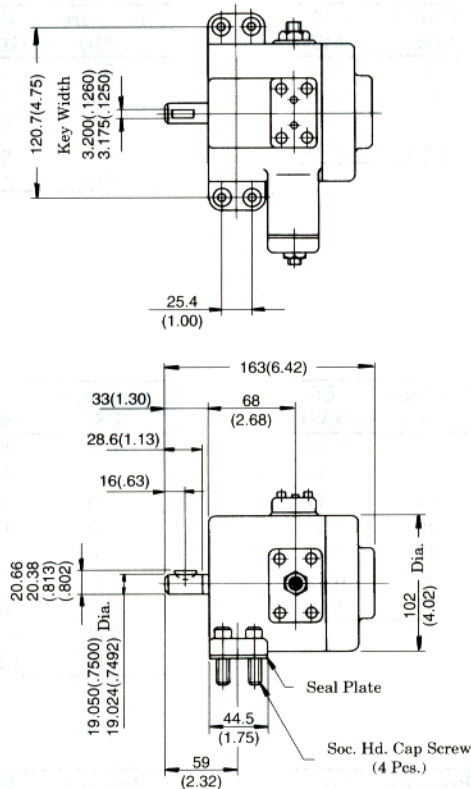

● Mounting Bolt

Model Numbers	Soc. Hd. Cap Screw (4 Pcs.)
VPVQ-PSS*-***R-60	M10 x 25 Lg.
VPVQ-PSS*-***R-6090	3/8-16 UNC x 1 Lg.

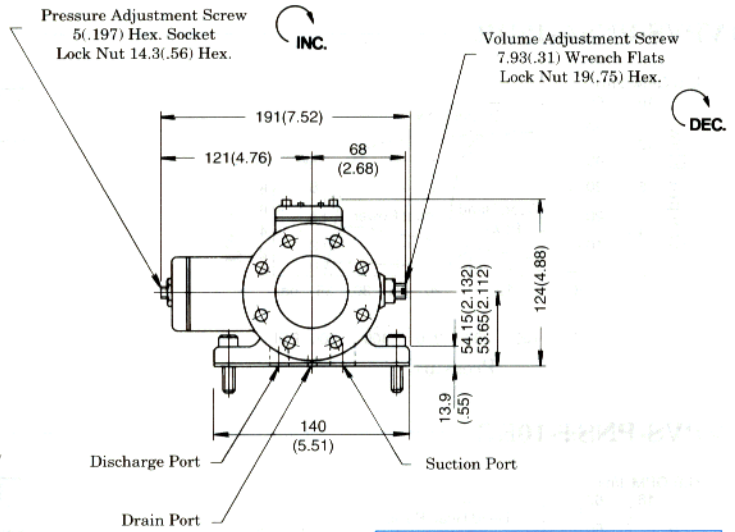

DIMENSIONS IN MILLIMETRES (INCHES)

VPVQ-PSA*-***R-60

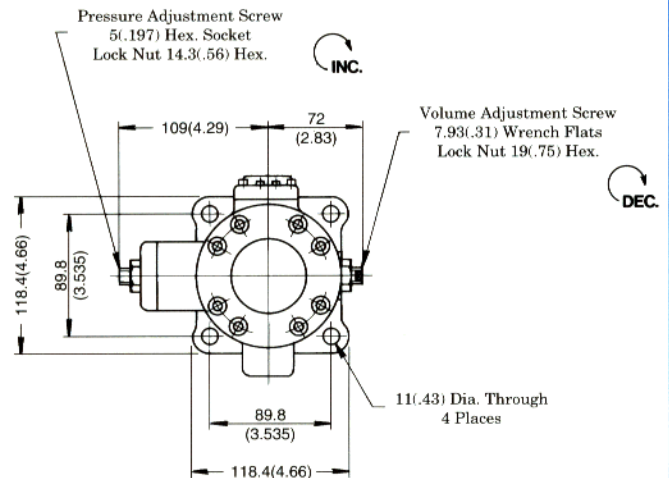
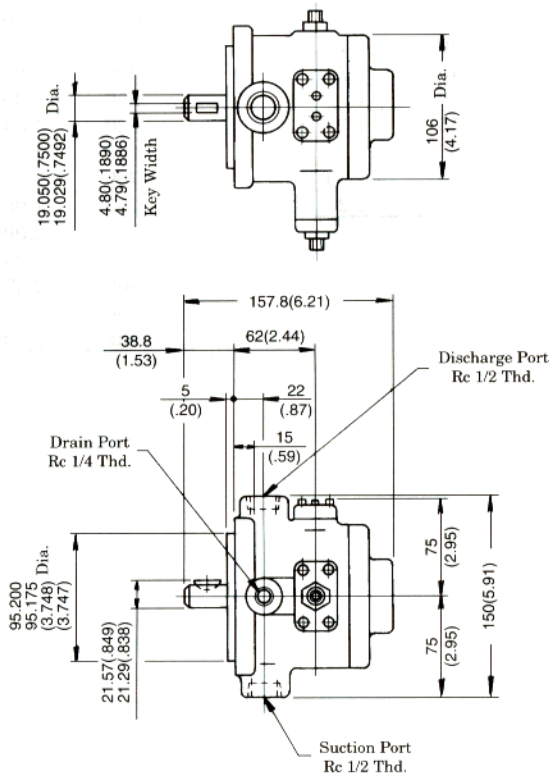

VPVS-PNS***R-51/5190

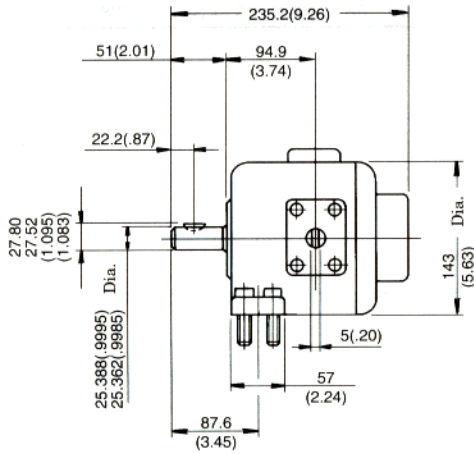
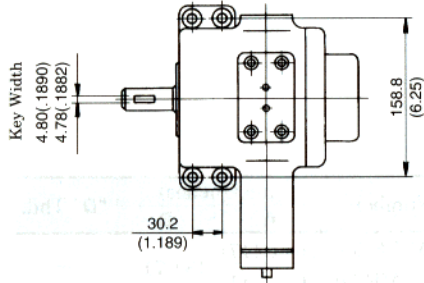

● **Mounting Bolt**

Model Numbers	Soc. Hd. Cap Screw (4 Pcs.)
VPVS-PNS***R-51	M12 x 30 Lg.
VPVS-PNS***R-5190	7/16-14 UNC x 1-3/16 Lg.

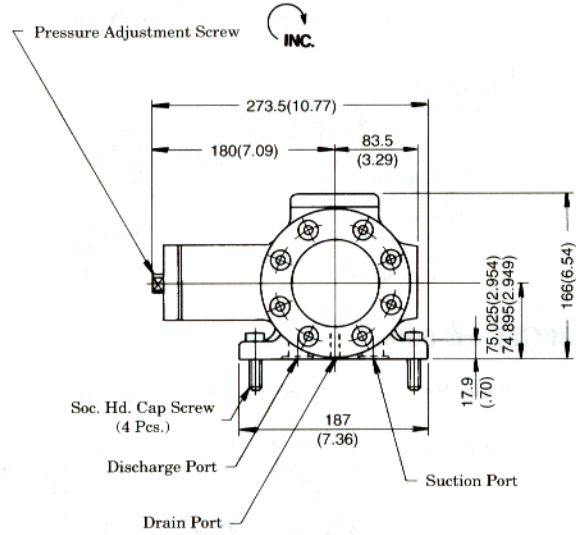

DIMENSIONS IN
MILLIMETRES (INCHES)

■ Sub-plates for "VPVQ" Series Pump

● VPV20GM-***E-50**

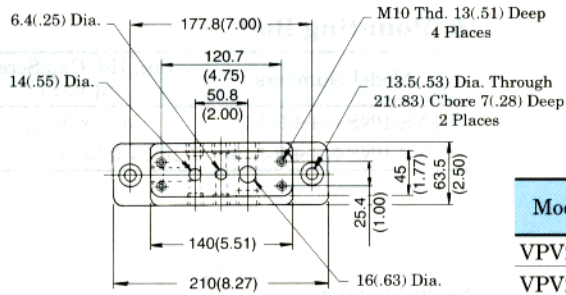

Model Numbers	mm (Inches)		"D" Thd.
	A	B	
VPV20GM-LE-50	36 (1.417)	18 (.71)	—
VPV20GM-ME-50	46 (1.811)		
VPV20GM-HE-50	58 (2.283)	35 (1.38)	3/8

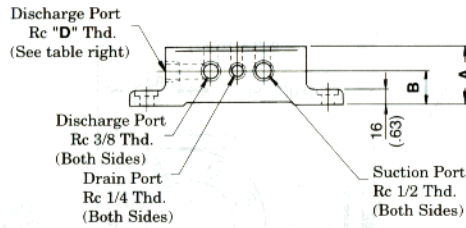

● VPV20GM-***E-5080**

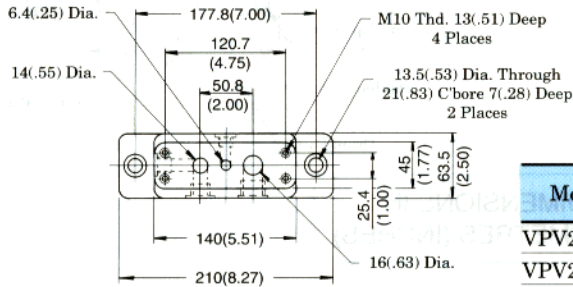

Model Numbers	mm (Inches)		"C" Thd.	"D" Thd.
	A	B		
VPV20GM-LE-5080	36 (1.417)	18 (.71)	3/8	—
VPV20GM-ME-5080	46 (1.811)			
VPV20GM-HE-5080	58 (2.283)	35 (1.38)	—	3/8

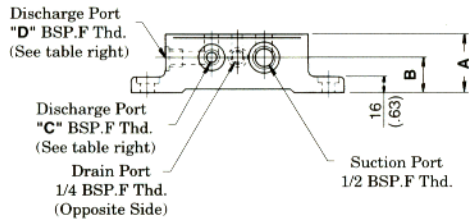

● VPV20GM-***-5090**

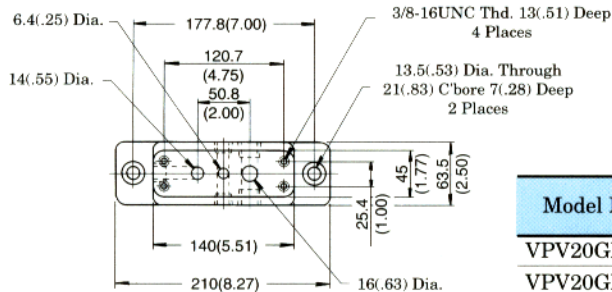

Model Numbers	mm (Inches)	
	A	B
VPV20GM-L-5090	60.3 (2.374)	31.7 (1.25)
VPV20GM-H-5090	79.4 (3.126)	38.1 (1.50)

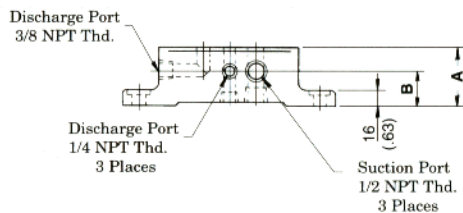

DIMENSIONS IN
MILLIMETRES (INCHES)

■ Sub-plates for “VPVS” Series Pump

● VPV40GM-HE-50

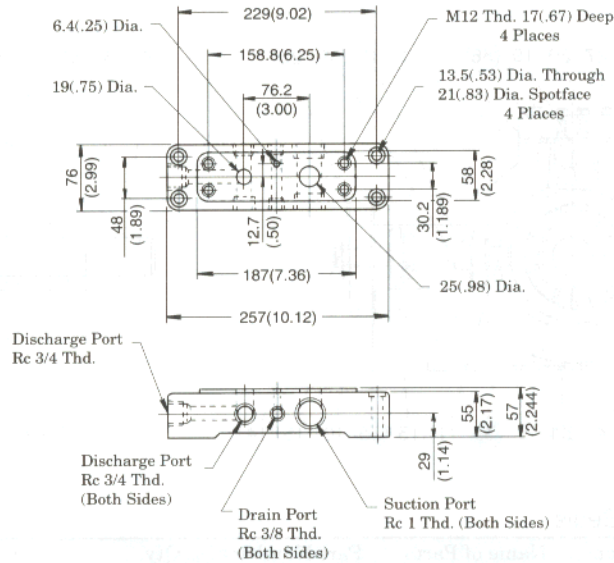

● VPV40GM-HE-5080

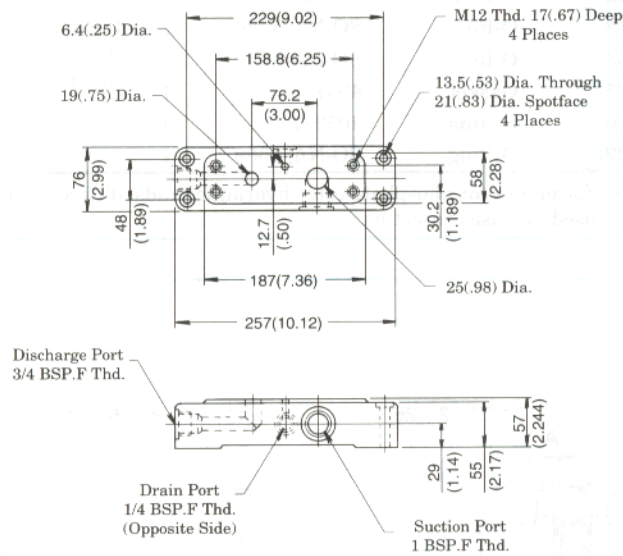

● VPV40GM-**-5090

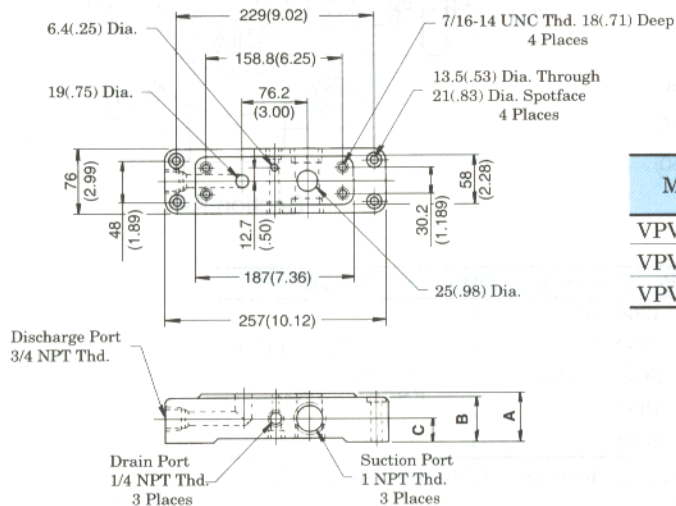

Model Numbers	mm (Inches)		
	A	B	C
VPV40GM-L-5090	58.4 (2.299)	56.4 (2.22)	28.9 (1.14)
VPV40GM-HE-5090	57 (2.244)	55 (2.17)	29 (1.14)
VPV40GM-H-5090	83.8 (3.299)	81.8 (3.22)	47.3 (1.86)

DIMENSIONS IN
MILLIMETRES (INCHES)

■ List of Seals

VPVQ-PSS*

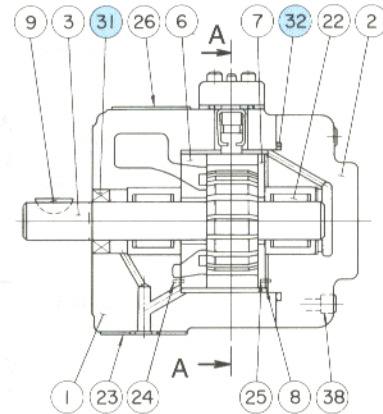
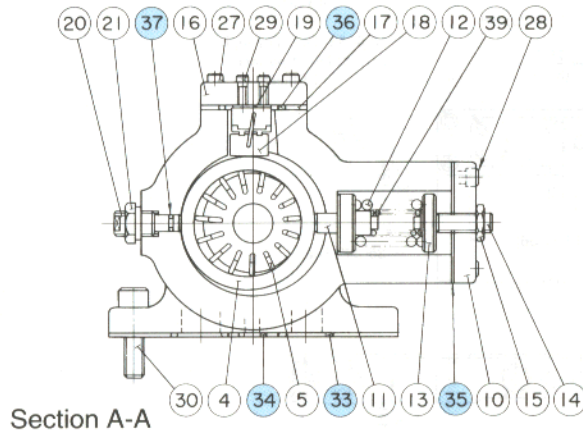

● Seals

Item	Name of Parts	Part Numbers	Qty.	Remarks
31	Oil Seal	406415A	1	Included in Seal Kit (Kit No.: KS-VPVQ-PSSO-60)
32	O-Ring	SO-NA-A148	1	
33	O-Ring	SO-NA-A020	2	
34	O-Ring	SO-NA-A012	1	
35	Gasket	405738	1	
36	O-Ring	405231	1	
37	O-Ring	SO-NA-A008	1	

Note: For pumps for phosphate ester hydraulic fluids, different part Nos. are used. Please contact us.

VPVQ-PSA*

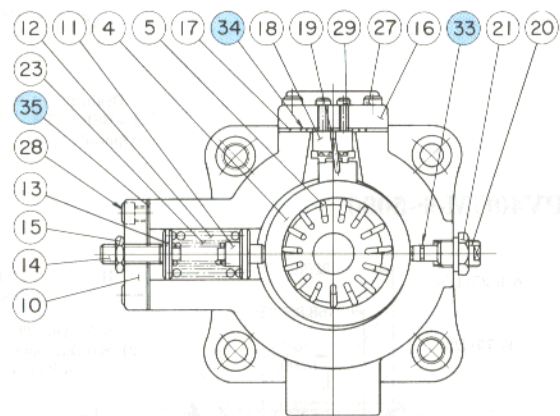
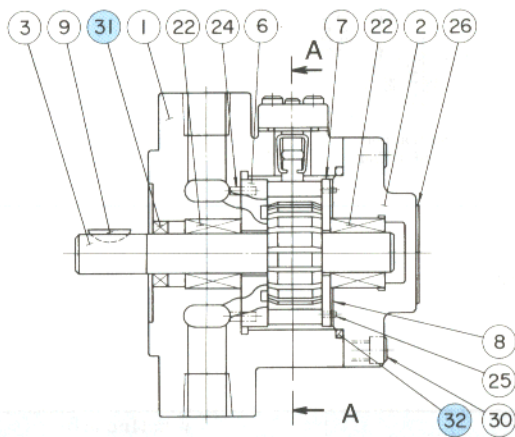

● Seals

Item	Name of Parts	Part Numbers	Qty.	Remarks
31	Oil Seal	406415A	1	Included in Seal Kit (Kit No.: KS-VPVS-PNSO-51)
32	O-Ring	SO-NA-A233	1	
33	O-Ring	SO-NA-A008	1	
34	O-Ring	405231	1	
35	Gasket	404207	1	

Note: For pumps for phosphate ester hydraulic fluids, different part Nos. are used. Please contact us.

■ List of Seals

VPVS-PNS*

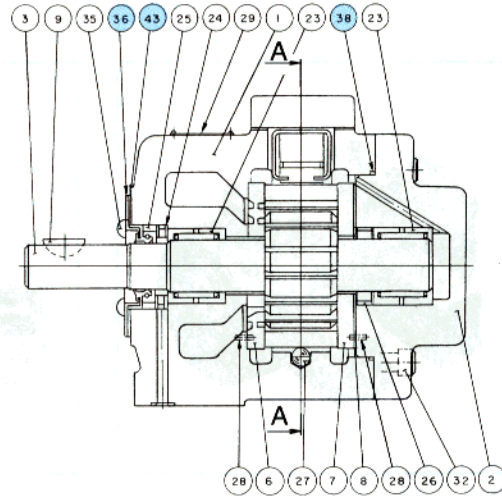
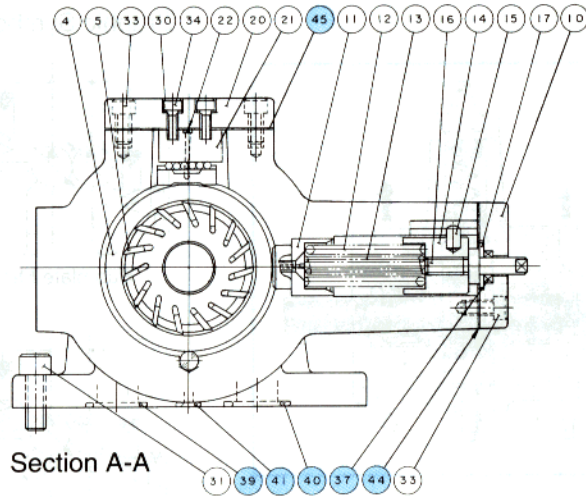

● Seals

Item	Name of Parts	Part Numbers	Qty.	Remarks
36	Oil Seal	404320B	1	Included in Seal Kit (Kit No.: KS-VPVS-PNSO-51)
37	Seal	404746	1	
38	O-Ring	SO-NA-A155	1	
39	O-Ring	SO-NA-A127	1	
40	O-Ring	SO-NA-A122	1	
41	O-Ring	SO-NA-A110	1	
43	Gasket	404322	1	
44	Gasket	404737	1	
45	Gasket	404736	1	

Note: For pumps for phosphate ester hydraulic fluids, different part Nos. are used. Please contact us.

Variable Displacement Double Vane Pumps

A pair of variable-displacement single vane pumps are combined on one shaft. Discharged fluid can be divided or united.

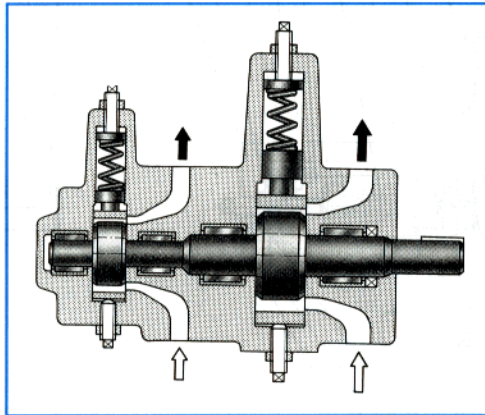
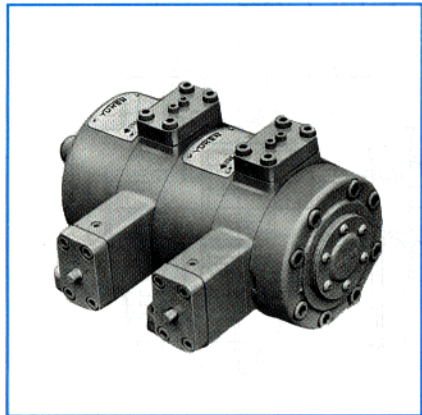

Graphic Symbols

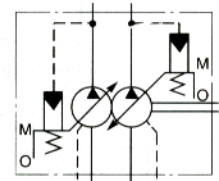

Sub-plate Mtg.

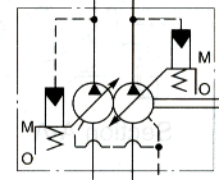

Flange Mtg.

Ratings

Model Numbers	Cover End Pump			Shaft End Pump			Shaft Speed Range		Mass kg (lbs.)	
	Max. Operating Pres. bar (PSI)	Output Flow at 3.5 bar (50 PSI) l/min (U.S.GPM)		Max. Operating Pres. bar (PSI)	Output Flow at 3.5 bar (50 PSI) l/min (U.S.GPM)		Max.	Min.		
		at 1200 rpm (r/min)	at 1800 rpm (r/min)		at 1200 rpm (r/min)	at 1800 rpm (r/min)				
Sub-plate Mtg.	VPVQQ-PSS*-05E-PSS*-05EA-60*	70 (1000)	13.3 (3.5)	20 (5.3)	70 (1000)	13.3 (3.5)	20 (5.3)	1800	400	12.5 (27.6)
	VPVQQ-PSS*-06C-PSS*-05EA-60*	35 (500)	17.3 (4.6)	26 (6.9)	70 (1000)	13.3 (3.5)	20 (5.3)			
	VPVQQ-PSS*-06C-PSS*-06CA-60*				35 (500)	17.3 (4.6)	26 (6.9)			
	VPVQQ-PSS*-06B-PSS*-05EA-60*	17.5 (250)	17.3 (4.6)	26 (6.9)	70 (1000)	13.3 (3.5)	20 (5.3)			
	VPVQQ-PSS*-06B-PSS*-06CA-60*				35 (500)	17.3 (4.6)	26 (6.9)			
	VPVQQ-PSS*-06B-PSS*-06BA-60*				17.5 (250)	17.3 (4.6)	26 (6.9)			
VPVQQ-PSA*-05E-PSA*-05EA-60	70 (1000)				13.3 (3.5)	20 (5.3)	70 (1000)	13.3 (3.5)	20 (5.3)	
Flange Mtg.	VPVQQ-PSA*-06C-PSA*-05EA-60	35 (500)	18.6 (4.9)	28 (7.4)	70 (1000)	13.3 (3.5)	20 (5.3)	1800	400	14 (30.9)
	VPVQQ-PSA*-06C-PSA*-06CA-60	17.5 (250)	18.6 (4.9)	28 (7.4)	35 (500)	18.6 (4.9)	28 (7.4)			
	VPVQQ-PSA*-06B-PSA*-06CA-60				35 (500)	18.6 (4.9)	28 (7.4)			
	VPVQQ-PSA*-06B-PSA*-06BA-60				17.5 (250)	18.6 (4.9)	28 (7.4)			

Note: Pump inlet equals the sum of the inputs of the component pumps.
The maximum allowable input is 3.7 kW (5 HP).
Take care about operating pressures and discharges so that the total input will not exceed the allowable values.

Yuken can offer large volume double Pump described below.
Consult Yuken for the details.

Model Numbers	Max. Operating Pressure bar (PSI)	Output Flow at 1200 rpm (r/min) at No-load with 32 cSt (150 SSU) Fluids l/min (U.S.GPM)		Shaft Speed Range rpm (r/min)
		Small Volume	Large Volume	
VPVQ-PNA*-**-*NT*-**A-50	70 (1000)	13-17 (3.4-4.5)	56-120 (14.8-31.7)	400-1500

Model Number Designation

VPVQQ	Cover End Pump						Shaft End Pump						A	-60	#		
	-P	S	S	O	-05	E	-P	S	S	O	-05	E					
Series Number	Type of Compensator	Volume Control	Mounting	Applicable Hydraulic Fluids	Delivery Designation	Pressure Compensating Range bar (PSI)	Type of Compensator	Volume Control	Mounting	Applicable Hydraulic Fluids	Delivery Designation	Pressure Compensating Range bar (PSI)	Direction of Rotation	Design Number	Design Std.		
VPVQQ	P: Pressure Compensator	S: With Screw Volume Control	S: Sub-plate Mtg.	O: Petroleum Base Oils	05	E: 35-70 (500-1000)	P: Pressure Compensator	S: With Screw Volume Control	S: Sub-plate Mtg.	O: Petroleum Base Oils	05	E: 35-70 (500-1000)	(Viewed from Shaft End)	A: Clockwise	60	None: Japanese Std. "JIS" & European Design Std. 90: N. American Design Std.	
					06	C: 17.5-35 (250-500) B: 7-17.5 (100-250)					06	C: 17.5-35 (250-500) B: 7-17.5 (100-250)					
				F: Phosphate Esters	05	E: 35-70 (500-1000)				F: Phosphate Esters	05	E: 35-70 (500-1000)					
					06	C: 17.5-35 (250-500) B: 7-17.5 (100-250)					W: Water-Glycols	06					C: 17.5-35 (250-500) B: 7-17.5 (100-250)
			A: Flange Mtg.	W: Water-Glycols	A: Flange Mtg.	W: Water-Glycols			05	E: 35-70 (500-1000)		A: Flange Mtg.			W: Water-Glycols		05
									06	C: 17.5-35 (250-500) B: 7-17.5 (100-250)	06						C: 17.5-35 (250-500) B: 7-17.5 (100-250)

Note: Select models from the table of ratings. No combinations of other models are allowed.

Typical Pump Characteristics

Characteristics are the same as for variable displacement single vane pumps. See the characteristics charts concerned.

Mounting Bolts

Only the subplate mounting type pumps are accompanied with the following mounting bolts.

Pump Model Numbers	Socket Head Cap Screw (8 Pcs.)	
	Japanese Std. "JIS" & European Design Std.	N. American Design Std.
VPVQQ-PSS*-**-PSS*-**A	M10 x 25 Lg.	3/8-16UNC x 1 Lg.

Sub-plates

Pump Model Numbers	Japanese Std. "JIS"		European Design Std.		N. American Design Std.	
	Sub-plate Model Numbers	Mass kg (lbs.)	Sub-plate Model Numbers	Mass kg (lbs.)	Sub-plate Model Numbers	Mass kg (lbs.)
VPVQQ-PSS*-**-PSS*-**A	VPV2020GM-E-50	7.5 (16.5)	VPV2020GM-E-5080	7.2 (15.9)	VPV2020GM-E-5090	7.3 (16)

- Sub-plates are available. Specify sub-plate model from the table above. When sub-plates are not used, the mounting surface should have a good machined finish.

VPVQQ-PSS*-**-PSS*-**-A-60/6090

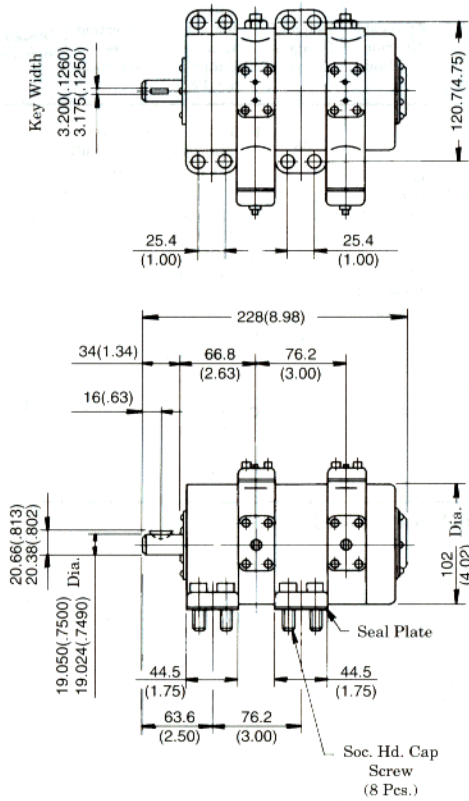

● Mounting Bolt

Model Numbers	Soc. Hd. Cap Screw (8 Pcs.)
VPVQQ-PSS*-**-PSS*-**-A-60	M10 x 25 Lg.
VPVQQ-PSS*-**-PSS*-**-A-6090	3/8-16 UNC x 1 Lg.

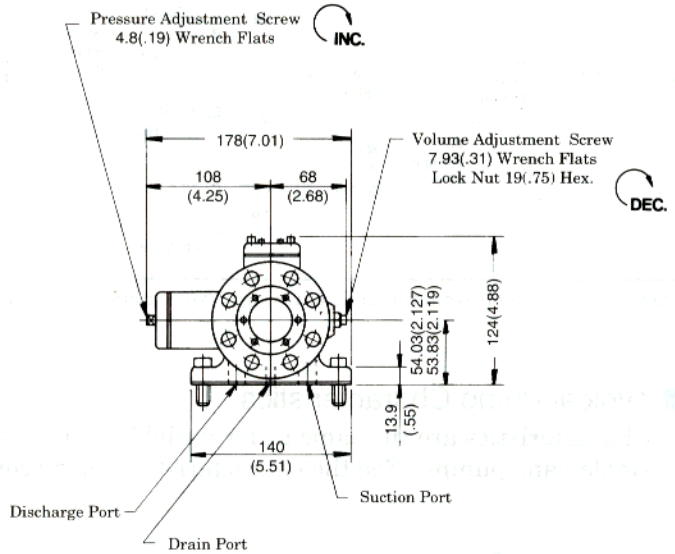

DIMENSIONS IN MILLIMETRES (INCHES)

VPVQQ-PSA*-**-PSA*-**-A-60

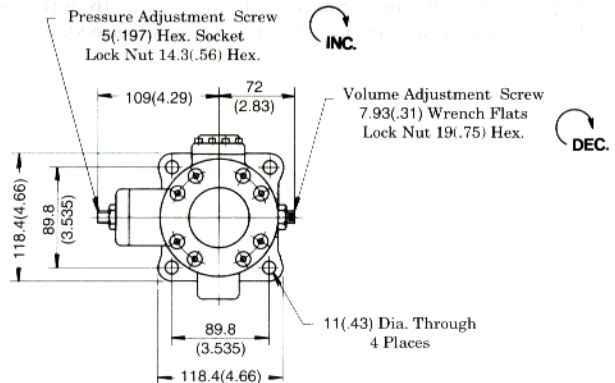
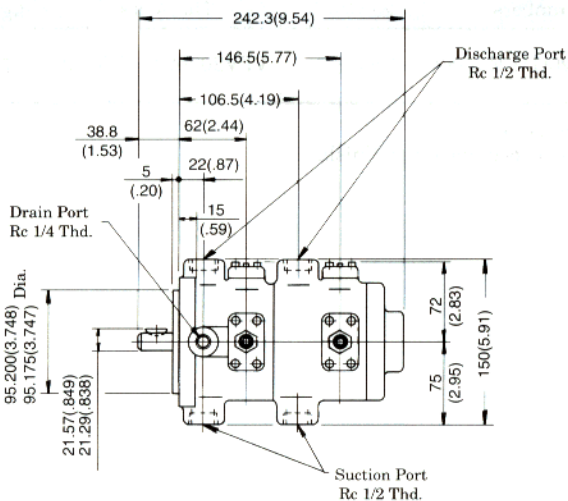
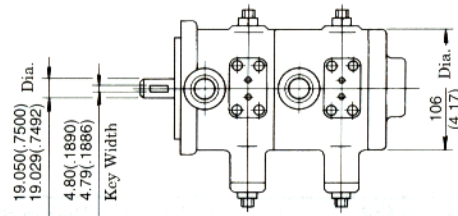

■ Sub-plates for “VPVQQ” Series Pump

● VPV2020GM-E-50

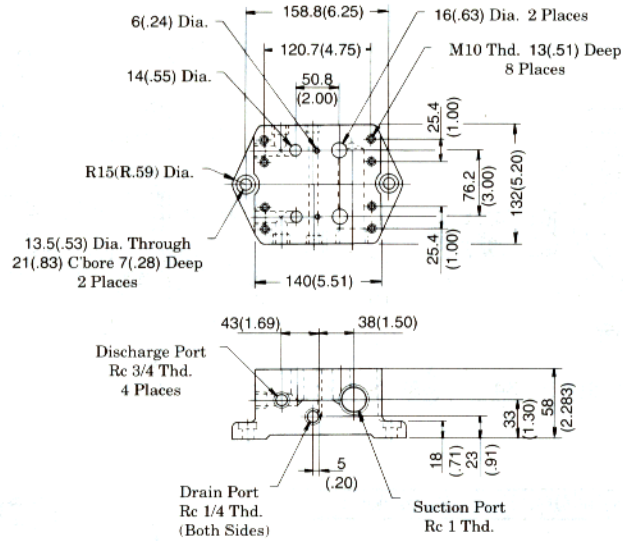

● VPV2020GM-E-5080

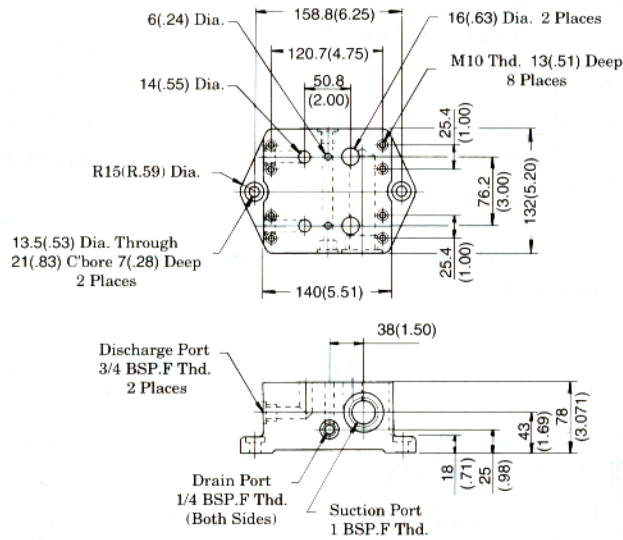

● VPV2020GM-E-5090

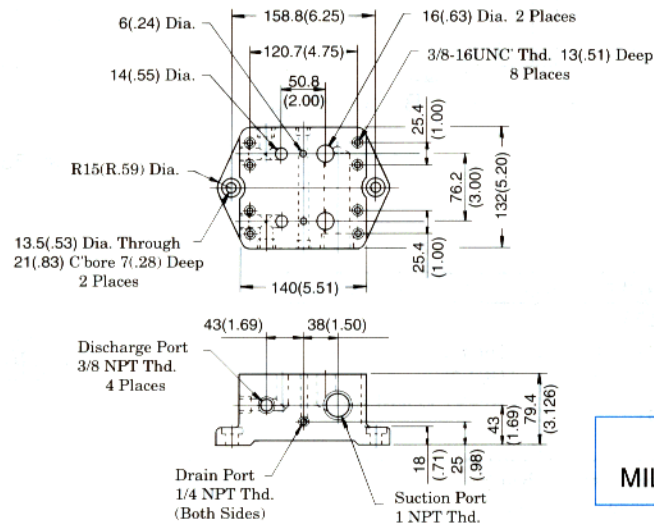

DIMENSIONS IN
MILLIMETRES (INCHES)

■ List of Seals

VPVQQ-PSS*-**-PSS*-**A

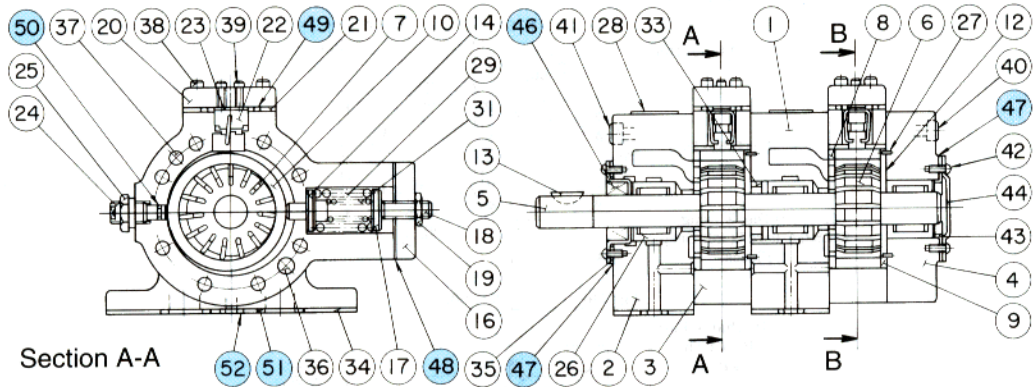

● Seals

Item	Name of Parts	Part Numbers	Qty.	Remarks
46	Oil Seal	405140	1	
47	Gasket	402325	4	
48	Gasket	404207	2	Included in Seal Kit (Kit No.: KS-VPVQQ-PSSO-60)
49	O-Ring	405231	2	
50	O-Ring	SO-NA-A008	2	
51	O-Ring	SO-NA-A020	4	
52	O-Ring	SO-NA-A012	2	

Note: For pumps for phosphate ester hydraulic fluids, different part Nos. are used. Please contact us.

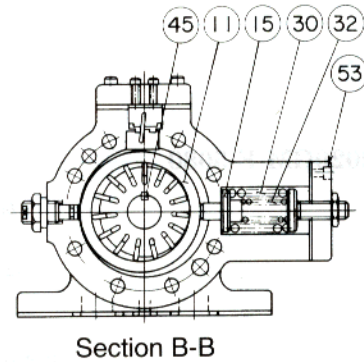

VPVQQ-PSA*-**-PSA*-**A

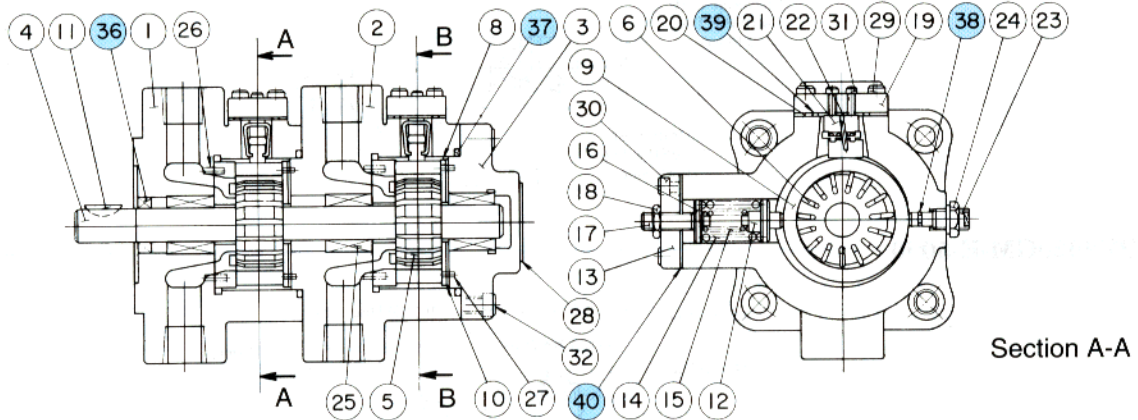

● Seals

Item	Name of Parts	Part Numbers	Qty.	Remarks
36	Oil Seal	406415A	1	
37	O-Ring	SO-NA-A233	2	Included in Seal Kit (Kit No.: KS-VPVQQ-PSAO-60)
38	O-Ring	SO-NA-A008	2	
39	O-Ring	405231	2	
40	Gasket	404207	2	

Note: For pumps for phosphate ester hydraulic fluids, different part Nos. are used. Please contact us.

